

Technical guide



**FLUE GAS SYSTEMS,
VITODENS**

Index

1. Flue gas systems	1.1	4
	■ Structural unit	4
	■ System certification	4
	1.2 Balanced flue operation	4
	1.3 Open flue operation	5
	1.4 Flue gas high limit safety cut-out	5
	1.5 Lightning protection	5
	1.6 CE certification for the PPs flue gas systems (rigid and flexible) for the Vitodens	6
	1.7 Flue installation options for balanced flue operation	7
	■ Inside the living space (occupied areas) with one or several full floors above	7
	■ Inside the living space (occupied area), immediately underneath the roof or only with attics above (rated output ≤ 50 kW)	8
	■ Several Vitodens in the living space or in occupied rooms (living space - rated output ≤ 50 kW)	8
	1.8 Flue installation options for open flue operation	8
	■ Inside the installation location (non-living space) with one or several full floors above (compulsory for the Vitodens 200-W from 60 kW)	9
	■ Special types: open flue operation and installation location in the living space (occupied area) with combustion air supply via interconnected rooms (rated output ≤ 35 kW)	9
	■ Flue gas header for several Vitodens 200-W – positive pressure	10
	■ Flue gas header for several Vitodens – negative pressure	10
2. Design and sizing information for connection on the flue gas side	2.1 Plastic (PPs) balanced flue system for routing through a duct – balanced flue operation (type C _{63x} to TRGI 2008)	10
	■ Minimum internal duct dimensions to DIN 18160	11
	■ Flue, system size 60, 80 and 100 (components) (type C _{63x} according to TRGI 2008)	12
	■ Vitodens in conjunction with solid fuel boilers	13
	■ Flue, flexible, system size 60, 80 and 100 (components) (type C _{63x} according to TRGI 2008)	15
	2.2 Plastic (PPs) balanced flue system for vertical routing through a pitched or flat roof (type C _{33x} to TRGI 2008)	16
	■ For vertical roof outlets when the Vitodens is installed in attics	16
	■ Vertical flat roof outlet	16
	2.3 Plastic (PPs) balanced flue system for external wall outlets (type C _{13x} to TRGI 2008)	18
	■ Max. total length of the flue pipe	18
	2.4 Plastic (PPs) balanced flue system for routing over external walls (type C _{53x} to TRGI 2008)	19
	2.5 Plastic (PPs) balanced flue system for routing through a lightweight duct	21
	■ "UNIFIX" duct profiles offered by Skoberne (made from aerated concrete)	21
	■ "SKOBIFIXnano" and "SKOBIFIXs 30" duct profiles offered by Skoberne (made from foamed ceramics)	21
	■ Anchoring for roof outlets with duct profiles	21
	■ Promat duct profiles	22
	■ Roof outlet for ducts with Promat profiles	23
	2.6 Plastic (PPs) balanced flue system for routing multiple pipes through a duct	23
	■ Layout examples	23
	2.7 Plastic (PPs) balanced flue system (connecting line) for connecting multiple flues to a single room sealed balanced flue	24
	■ Room sealed balanced flue, negative pressure (type C _{43x} to TRGI 2008)	25
	■ Room sealed balanced flue, positive pressure – multiple connection with the Vitodens 200-W (type C _{43x} to TRGI 2008)	25
	2.8 Plastic (PPs) flue pipe for routing through a duct with open flue operation (type B according to TRGI 2008)	26
	■ Minimum internal duct dimensions	27
	■ Flue, system size 60, 80 and 100 (components) (type B ₂₃ /B ₃₃ according to TRGI 2008)	28
	■ Flue, flexible, system size 60, 80 and 100 (components) (type B _{23x} according to TRGI 2008)	29
	■ Special types: Open flue operation with combustion air supply via interconnected rooms for the Vitodens up to 35 kW (type B ₃₃ according to TRGI 2008)	30
	■ Connection to a moisture-resistant chimney (MR chimney negative pressure) with a plastic (PPs) flue pipe (type B _{23x} , according to TRGI 2008)	31
	■ Multi-boiler systems with flue gas systems operating with positive pressure (open flue operation) – Vitodens 200-W, 19 to 105 kW	32
	■ Multi-boiler systems with flue gas systems - negative pressure	37

5414 641 GB

Index (cont.)

3. Flue gas system components	
3.1	Balanced flue system components 37
3.2	Components for routing a flue over an external wall 41
3.3	Single pipe system components 43
3.4	Components for multiple connections to a room sealed balanced flue – positive pressure for the Vitodens 200-W (4.8 to 26 kW) 45
3.5	Components of the flexible single pipe system for a flexible flue 46
3.6	Components for multi-boiler systems 48
3.7	Roof elements 50
4. Keyword index 51

Flue gas systems

The following requirements regarding design and installation apply to flue gas systems for condensing combustion equipment:

Prior to starting work on the flue gas system, your heating contractor should confer with the flue gas inspector responsible [where applicable].

Gas combustion equipment must be connected to the domestic chimney stack on the same floor where it is installed (no transition through separating ceilings).

Here, differentiation is required as to whether the condensing boiler should be installed **in the living space** (occupied rooms) or **outside the living space** (installation room).

An installation of the Vitodens in the **living space** is feasible, subject to the flue pipe inside the living space being routed inside a protective pipe and being surrounded by ventilation air (balanced flue system, **balanced** flue operation).

As special case, an installation inside the living space is also feasible for **open** flue operation, provided a union with secondary ventilation (operation with interconnected room air supply) is provided up to the duct (see page 30).

Structural unit

The aforementioned conditions are generally met when one of the flue gas systems (accessories) that are CE-certified with the Vitodens is used.

The following Viessmann balanced flue systems for **balanced** flue operation are tested to DVGW and are CE-designated as a **single structural unit** with the Vitodens:

- Vertical roof outlet
 - External wall connection
 - Horizontal roof outlet
 - Routing over an external wall through a coaxial pipe
- Advantages of single structural units:
- No calculated function verification for flue pipes to DIN EN 13384 is required for individual cases
 - Simplified visual inspection by the local flue gas inspector every two years
 - No additional approval certificate by the flue pipe manufacturer required

In a **non-living space**, the flue may also be installed inside the installation room without secondary ventilation. However, the installation room would then require an adequately sized ventilation aperture to the outside (acc. to TRGI 2008).

Rated output up to 50 kW:

150 cm² or 2 × 75 cm²

Rated output above 50 kW (e.g. Vitodens 200-W, from 60 kW, or multi-boiler systems):

150 cm² and 2 cm² for each kW above 50 kW

The plain flue pipe must be type approved by the Deutsche Institut für Bautechnik (DIBt) [Germany] (**open** flue operation).

The flue available as an accessory is CE-designated and approved in accordance with DIN EN 14471.

System certification

System certification to DVGW-VP 113 and EC Gas Equipment Directive 90/396/EEC in conjunction with PPs flue pipes offered by Sko-berne

Vitodens 200-W	CE-0085 BR 0432
Vitodens 222-F	CE-0085 BU 0051
Vitodens 222-W	CE-0085 BR 0432
Vitodens 242-F	CE-0085 BU 0051
Vitodens 300-W	CE-0085 BR 0433
Vitodens 333-F	CE-0085 BU 0052
Vitodens 343-F	CE-0085 BU 0052

1.2 Balanced flue operation

The sealed combustion chamber of the Vitodens gas condensing boilers enables their use in **balanced** flue operation. These boilers are categorised as C_{13x}, C_{33x}, C_{43x}, C_{53x}, C_{63x} or C_{83x} according to TRGI 2008.

A **common approval** for the Vitodens and balanced flue system applies to this type of equipment.

The tightness test (overpressure test) by the flue gas inspector during commissioning as well as the verification of the "General Building Regulations approval" by the DIBt may be omitted for this type of construction.

Every approved flue gas system can be used for type C_{63x}. This flue gas system is not tested together with the boilers.

Maintain the dimensions stated on pages 10 to 19. The combustion air is supplied and the flue gas extracted through one concentric coaxial pipe (balanced flue system). The combustion air is supplied through the annular gap between the external aluminium ventilation air pipe and the flue pipe. Flue gases are extracted through the internal plastic pipe (PPs).

For balanced flue systems tested together with the wall mounted gas boiler, the requirement for a tightness test during commissioning by the flue gas inspector is not applicable.

We recommend that your heating engineer carries out a simple tightness test during the commissioning of your system. For this it would be sufficient to check the CO₂ concentration in the combustion air at the annular gap of the balanced flue pipe. The flue pipe is deemed to be gas-tight if the CO₂ concentration in the combustion air is no higher than 0.2 % or the O₂ concentration is at least 20.6 %.

Check the flue gas system for tightness by pressure testing if higher CO₂ or lower O₂ values are established.

In conjunction with the concentric coaxial pipe (balanced flue system), the surface temperature of the Vitodens or that of the balanced flue system will never exceed 85 °C. Therefore, clearances to combustible components according to TRGI are **not** required.

For boiler types C_{63x} and C_{43x}, the DIBt-approved flue pipes from Viessmann or alternative DIBt-approved flue pipes by other manufacturers may also be used.

Use a condensate trap above the boiler flue connection if an aluminium flue pipe is installed. Install the connecting lines with a slope of at least 3° to the boiler.

The balanced flue system is CE-designated and approved in accordance with DIN EN 14471 (see page 6).

The boiler casing creates a system that is sealed against its surroundings. Any leaks caused by escaping flue gas are returned via the combustion air, thereby preventing flue gas from entering the installation location.

Flue gas systems (cont.)

When installing the Vitodens in a basement or on a lower floor, an existing chimney or duct of adequate size may be used for the balanced flue operation (type C_{43x} and C_{63x}).

According to TRGI 2008, flue pipes that bridge several floors must be routed inside a duct with a fire rating of at least 90 minutes, and for buildings of low height with at least 30 minutes.

The balanced flue gas/ventilation air is routed in a balanced flue pipe up to the chimney or duct. The flue pipe is routed inside the chimney or duct to above roof level.

Where no suitable duct is available, the flue may be routed to the roof through a retrofitted duct. This duct must have Building Regulations approval and offer a fire rating to class F30 or F90.

1.3 Open flue operation

(Type B23 and B33)

Flue gas is routed through single wall plastic pipes (PPs). The flue gas system is CE-designated and approved in accordance with DIN EN 14471 (see page 6).

The combustion air supply is ensured via the annular gap between the flue pipe and the ventilation air inlet on the boiler flue connection of the Vitodens.

1.4 Flue gas high limit safety cut-out

According to CE designation in accordance with DIN EN 14471, the plastic flue pipe (PPs) can be utilised up to a max. flue gas temperature of 120 °C (type B).

Measures inside the equipment ensure that the flue gas temperature of 90 °C will never be exceeded. A flue gas high limit safety cut-out is therefore not required.

1.5 Lightning protection

If a lightning protection system is installed, any metallic flue gas system should be included in the lightning protection scheme.

1

1.6 CE certification for the PPs flue gas systems (rigid and flexible) for the Vitodens

1

ZERTIFIKAT ◆ CERTIFICATE ◆ 認証証書 ◆ CERTIFICADO ◆ CERTIFIKAT ◆ CERTIFICAT

ZERTIFIKAT

0036 CPD 9184 001



Industrie Service

Gemäß der Richtlinie 89/106/EWG des Rates vom 21. Dezember 1988 über die Angleichung der Rechts- und Verwaltungsvorschriften der Mitgliedsstaaten für Bauprodukte (Bauproduktenrichtlinie), ergänzt um die Richtlinie 93/68/EWG des Rates vom 22. Juli 1993 wird bestätigt, dass für die

**System-Abgasanlage
mit einer Innenschale aus PP**

Ausführungen

ohne Außenschale	EN 14 471 T120 H1 O W 2 O20 I E L
	EN 14 471 T120 H1 O W 2 O20 E E L
	EN 14 471 T120 P1 O W 2 O20 I E L
mit Kunststoff- außenschale	EN 14 471 T120 H1 O W 2 O00 I E L1
mit metallischer Außenschale	EN 14 471 T120 H1 O W 2 O00 E E L0
	EN 14 471 T120 P1 O W 2 O00 E E L0

hergestellt von

**Skoberne GmbH
Ostendstraße 1
64319 Pfungstadt**

in den Herstellwerken

**Skoberne GmbH
Ostendstraße 1
64319 Pfungstadt**

**Arkema GmbH
Am Bahnhof
25630 Ehringhausen**

- eine **erstmalige Typprüfung**, durchgeführt von TÜV SÜD Industrie Service GmbH, Bericht A 1614-00/07, und
- eine **werkseigene Produktionsüberwachung** vorliegen.

Die benannte Stelle TÜV SÜD Industrie Service GmbH hat die Erstprüfung des Werkes und der werkseigenen Produktionsüberwachung durchgeführt und führt weiterhin die ständige Überwachung, Beurteilung und Abnahme der werkseigenen Produktionsüberwachung durch.

Dieses Zertifikat bestätigt, dass alle Anforderungen für die Zertifizierung der werkseigenen Produktionsüberwachung entsprechend Anhang ZA der Norm

DIN EN 14 471: 2005-11

erfüllt werden.

Das Zertifikat wurde erstmalig am 2007-02-27 ausgestellt und ist gültig, solange die genannte Norm, die Herstellbedingungen und die werkseigene Produktionsüberwachung nicht wesentlich geändert sowie die Bedingungen des Zertifizierungsvertrags eingehalten werden. Die Gültigkeit des Zertifikats erlischt spätestens am 2012-02-26.

München, 2007-02-27

J. Steiglechner
.....
J. Steiglechner

TÜV SÜD INDUSTRIE SERVICE GMBH, RIDLERSTRASSE 65, D-80339 MÜNCHEN

5414 641 GB

1.7 Flue installation options for balanced flue operation

(no separate ventilation and extract air apertures required)

Inside the living space (occupied areas) with one or several full floors above

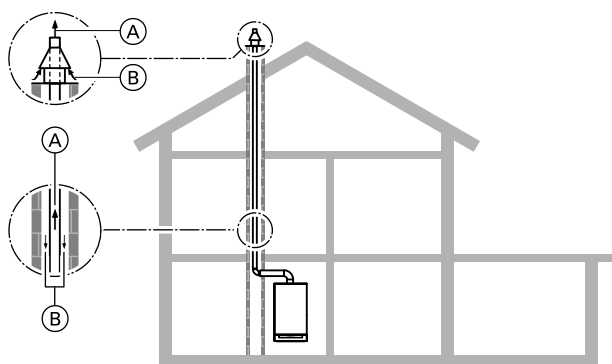

- (A) Flue gas
- (B) Ventilation air

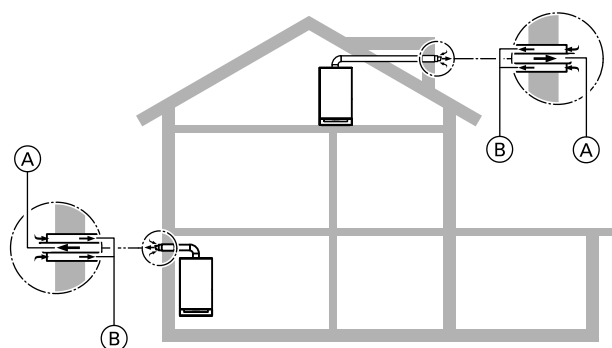

- (A) Flue gas
- (B) Ventilation air

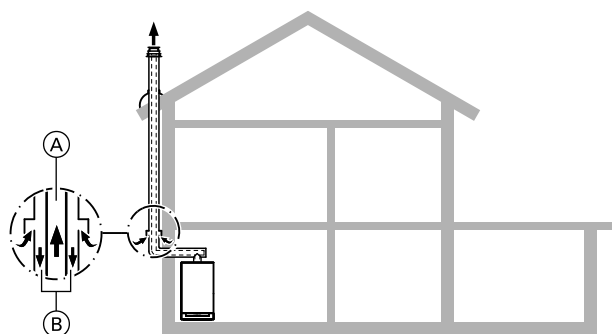

- (A) Flue gas
- (B) Ventilation air

Routing through a duct (Type C_{63x}, to TRGI 2008)

The boiler draws combustion air from the atmosphere through the annular gap inside the duct (chimney) and expels the flue gas via the flue pipe above roof level. For condensing boilers > 50 kW, the installation location **must** be ventilated even for **balanced** flue operation. The duct is not part of the standard delivery. For a detailed description, see from page 10.

Retrofitted ducts

Installation in a retrofitted duct with Building Regulation approval consisting of individual duct elements (e.g. as supplied by SIMO or Skoberne) or including mineral profiles (e.g. from Promatect). For a detailed description of ducts, see page 21.

External wall connection

Only for buildings with protected rights (Type C_{13x}, according to TRGI 2008)

(permissible up to a rated output of 11 kW for central heating or 28 kW for DHW heating)

According to the LandesFeuVo, issue 1999 [Germany], an external wall connection is only permissible in individual cases, where routing the flue gas by other means is not appropriate for technical or economical reasons.

The boiler draws combustion air from outside via a concentric coaxial pipe mounted to the external wall and expels flue gas via the outside wall to atmosphere. For a detailed description, see page 18.

Horizontal roof outlet

(Type C_{13x}, according to TRGI 2008)

(no limitation of the rated output)

The boiler draws combustion air from outside at the roof dormer via a concentric coaxial pipe and expels flue gas at the dormer to atmosphere.

Routing over an external wall

(Type C_{53x}, according to TRGI 2008)

The boiler draws combustion air from the atmosphere via a horizontal, concentric coaxial pipe on the external wall and expels flue gas to the atmosphere via the roof.

In its vertical section, the outside pipe of the concentric coaxial pipe acts as thermal insulation thanks to its static layer of air. The combustion air is supplied via the balanced flue air inlet.

For a detailed description, see page 19.

Flue gas systems (cont.)

Inside the living space (occupied area), immediately underneath the roof or only with attics above (rated output ≤ 50 kW)

1

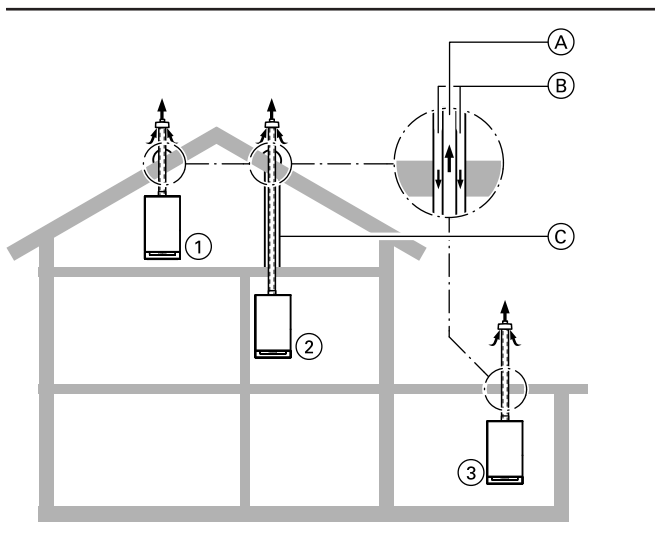

Vertical outlet, if no duct is available (Type C_{33x}, according to TRGI 2008)

(various options)

- ① direct, vertical roof outlet through a pitched roof
- ② indirect, vertical roof outlet through a pitched roof with protective pipe inside the attic space (not constructed as a room) or fire protection brickwork (constructed as a room)
- ③ direct, vertical roof outlet through a flat roof

The boiler draws combustion air from the atmosphere and expels flue gas to the atmosphere via a concentric coaxial pipe through the roof. For a detailed description, see page 16.

- (A) Flue gas
- (B) Ventilation air
- (C) Pipe to protect against mechanical damage

Several Vitodens in the living space or in occupied rooms (living space - rated output ≤ 50 kW)

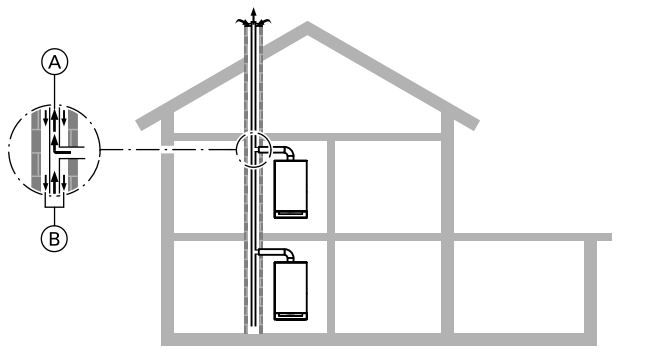

Installation on different floors (Type C_{43x}, according to TRGI 2008)

Operation with negative pressure:

Requires a room sealed balanced flue.

Operation with positive pressure:

Balanced flue system for multiple connections.

Several heat sources draw combustion air from the outside through the annular gap of the room sealed balanced flue and expel flue gas via the roof to atmosphere through a moisture-resistant internal pipe. For a detailed description, see pages 24 and 25.

- (A) Flue gas
- (B) Ventilation air

1.8 Flue installation options for open flue operation

(separate ventilation air aperture 150 cm² or 2×75 cm² cross-section required)

Flue gas systems (cont.)

Inside the installation location (non-living space) with one or several full floors above (compulsory for the Vitodens 200-W from 60 kW)

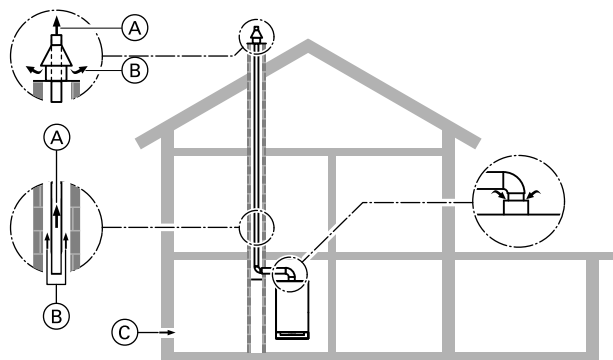

- (A) Flue gas
- (B) Secondary ventilation
- (C) Ventilation air

Routing through a duct (type B₂₃, according to TRGI 2008)

The boiler draws combustion air from the installation room and expels flue gas through the flue via the roof (balanced flow).
For a detailed description, see page 26.

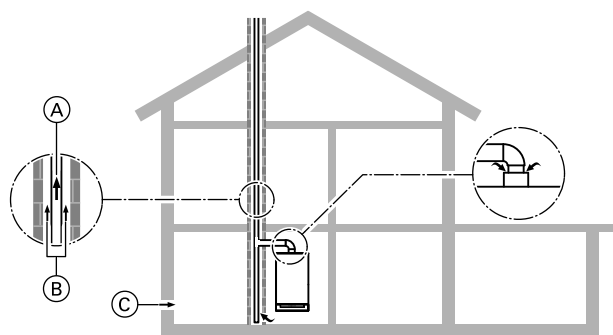

- (A) Flue gas
- (B) Secondary ventilation
- (C) Ventilation air

Connection to a moisture-resistant chimney (MR chimney) (type B₂₃, according to TRGI 2008)

The boiler draws combustion air from the installation room and routes flue gas through the moisture-resistant chimney via the roof.
For a detailed description, see page 31.

Special types: open flue operation and installation location in the living space (occupied area) with combustion air supply via interconnected rooms (rated output ≤ 35 kW)

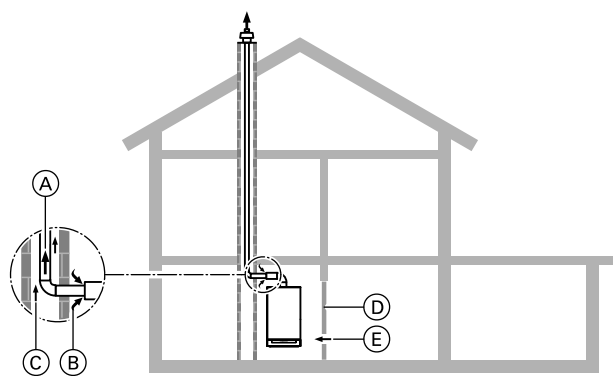

- (A) Flue gas
- (B) Ventilation air
- (C) Secondary ventilation
- (D) Door
- (E) Interconnected air supply

Routing through a duct or Connection to a moisture-resistant chimney (type B₃₃, according to TRGI 2008)

The boiler draws combustion air from the installation location via a coaxial pipe with ventilation air apertures upstream of the duct inlet and expels the flue gas either via a flue pipe or via a moisture-resistant chimney through the roof (combustion air supply via interconnected rooms according to TRGI).
For a detailed description, see page 30.

Flue gas systems (cont.)

Flue gas header for several Vitodens 200-W – positive pressure

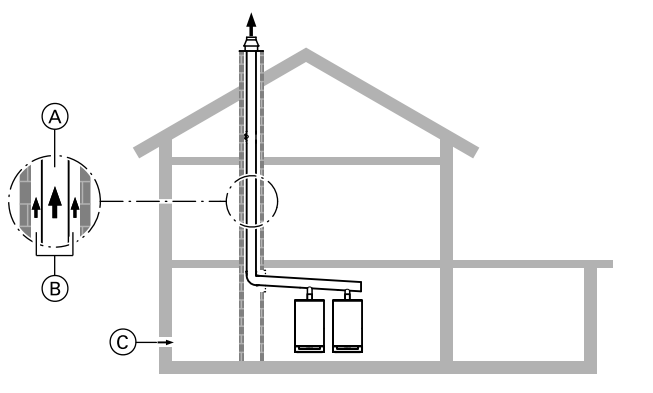

- (A) Flue gas
- (B) Secondary ventilation
- (C) Ventilation air

Type B₂₃, according to TRGI 2008

Several boilers inside the same room draw combustion air from outside via ventilation apertures and expel the flue gas through a common flue pipe via the roof to the atmosphere.

For a detailed description, see page 32.

2

Flue gas header for several Vitodens – negative pressure

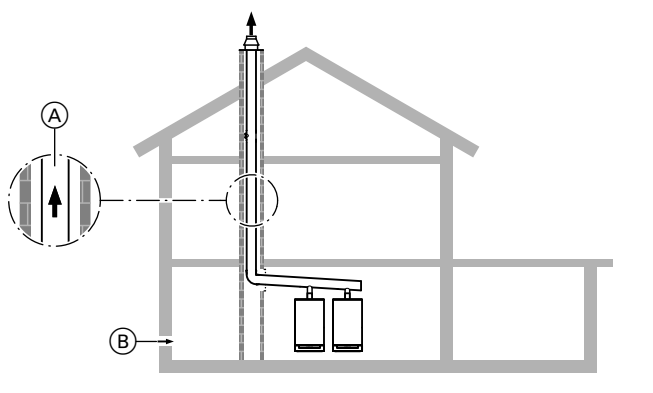

- (A) Flue gas
- (B) Ventilation air

Type B₂₃, according to TRGI 2008

Several boilers inside the same room draw combustion air from outside via ventilation apertures and expel the flue gas through a common flue pipe via the roof to the atmosphere.

For a detailed description, see page 37.

Design and sizing information for connection on the flue gas side

All details regarding length and cross-section in the following tables are only valid in connection with the balanced flue components offered in the Viessmann pricelist.

2.1 Plastic (PPs) balanced flue system for routing through a duct – balanced flue operation (type C_{63x} to TRGI 2008)

For **balanced flue** operation, a coaxial flue pipe (internal pipe for flue gas, external pipe for combustion air) is required as connecting piece between the Vitodens and the duct.

	Internal diameter Ø in mm	
	Flue pipe	Ventilation air pipe
Vitodens 200-W up to 35 kW, Vitodens 222-F, Vitodens 222-W, Vitodens 242-F, Vitodens 300-W and 333-F, up to 19 kW and Vitodens 343-F	60	100
Vitodens 200-W, 45 to 60 kW, Vitodens 300-W, 26 to 35 kW and Vitodens 333-F, 26 kW	80	125
Vitodens 200-W, 80 to 105 kW	100	150

The connecting piece is fitted to the boiler flue connection and must provide an inspection port.

5414 641 GB

Design and sizing information for connection on the flue gas side (cont.)

Note

Gas condensing boilers with a total rated output greater than 50 kW may only be installed in rooms that provide ventilation air apertures leading outside, see page 26.

For installation through ducts or channels with linear ventilation meeting the requirements for domestic chimney stacks to DIN 18160-1 or for a fire rating of 90 minutes (F90/L90), or a fire rating of 30 minutes (F30/L30) for low rise buildings (max. 2 storeys).

Prior to installation, the flue gas inspector should check that the duct to be used is suitable and approved for this purpose.

Ducts that were previously connected to oil or solid fuel boilers must be thoroughly cleaned by a chimney sweep. Loose deposits comprising sulphur and soot must not remain on the inside of the chimney.

Running a balanced flue pipe through the duct is then not required.

A separate ventilation air supply or a balanced flue can be used inside the duct, if thorough cleaning is impossible, if chloride deposits are present, or if the duct is silted up.

Close off and seal any other connection apertures with appropriate materials.

This does not apply to any cleaning or test apertures that are provided with chimney clean-out covers and to which an appropriate test mark has been affixed.

Check prior to installation whether the duct runs straight from top to bottom or if it is offset (check with mirrors).

If the chimney is offset, we recommend the installation of a flexible flue pipe (see page 15).

Inside the installation location, at least one inspection aperture must be provided in the flue system for checking and cleaning as well as for checking the pressure (if required). If the flue pipe is inaccessible from the roof, a second inspection aperture must be provided in the attic behind the chimney cleaning hatch. For further information, see FeuVo [Germany]

Provide an inspection aperture at the base of the duct for checking the secondary ventilation. Safeguard the unrestricted draining of the condensate from the flue into the boiler through an appropriate slope of at least 3°.

The flue system must be routed to above the roof (protrusion above the roof according to local regulations).

Alternative CE-designated flue pipes may be used, for example, if a larger flue pipe diameter is required, i.e. because of greater flue lengths. The function verification to EN 13384 should then be provided by the respective flue manufacturer.

If flue pipes other than those offered as accessories (which are approved with the Vitodens as single technical unit) are used, the flue gas system must be checked for tightness by the flue gas inspector prior to commissioning.

This may be carried out, in accordance with the approval certificate, by measuring the CO₂ or O₂ value inside the annular gap. Check the flue system for tightness, if this test results in a CO₂ content above 0.2 % or an O₂ content lower than 20.6 %.

2

Minimum internal duct dimensions to DIN 18160

Note

According to the approval certificate, internal duct dimensions smaller than shown in the table may also be used for balanced flue operation, if this is indicated by the function verification to DIN EN 13384.

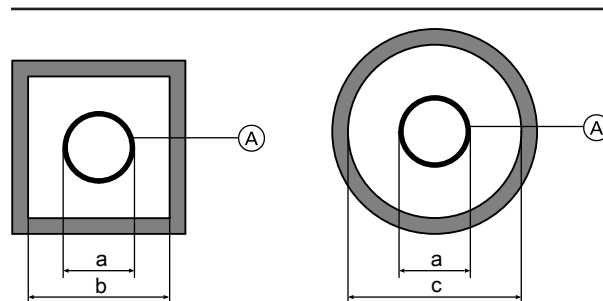

System size ^(A)	External diameter; fem. connection a	Minimum internal duct dimension	
	Ø mm	b square or rectangular (short side) mm	c round Ø mm
60	73	113	133
60 (flexible)	64	104	124
80	94	135	155
80 (flexible)	100	140	160
100	128	170	190
100 (flexible)	125	165	185

Design and sizing information for connection on the flue gas side (cont.)

Flue, system size 60, 80 and 100 (components) (type C_{63x} according to TRGI 2008)

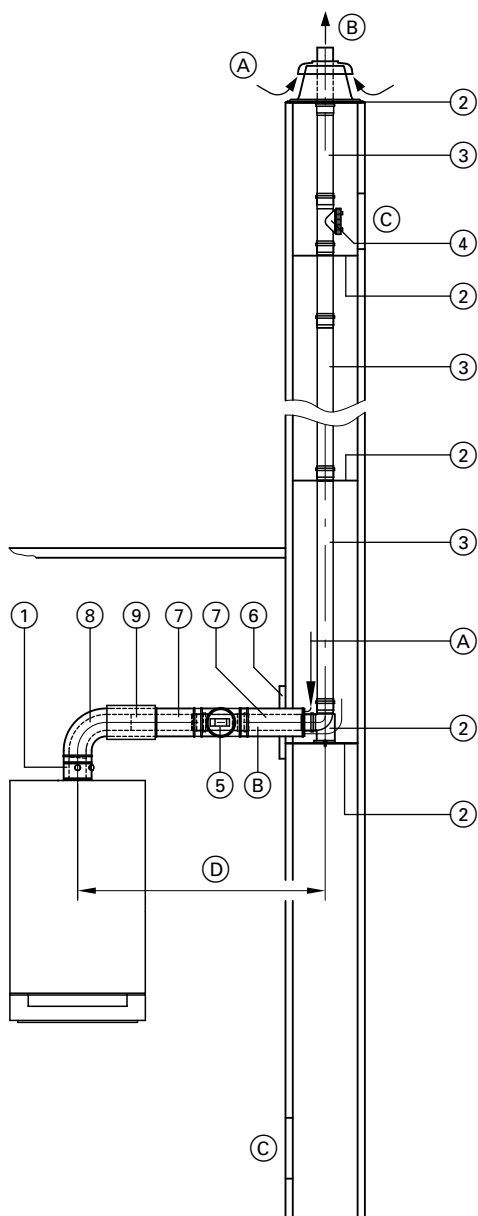

- (A) Ventilation air
 (B) Flue gas
 (C) Inspection aperture
 (D) Connecting piece

	System size Ø mm		
	60	80	100
① Boiler flue connection (part of the standard boiler delivery)	60	80	100
② Standard duct set (PPs, rigid) Comprising: – Support bend – Support rail – Duct cover – Spacers (3 pce, max. distance 5 m) or Standard duct pack (metal/PPs, rigid) for twin-draught chimneys; one draught for solid fuel boilers Comprising: – Support bend – Support rail – Duct cover – Terminal pipe (stainless steel) – Spacers (3 pce, max. distance 5 m)	60	80	100
Spacers (3 pce, max. distance 5 m)	60	80	100
③ Flue pipe 1.95 m long (2 pce @ 1.95 m = 3.9 m) 1.95 m long (1 pce) 1 m long (1 pce) 0.5 m long (1 pce)	60	80	100
Flue bend (for use in corbelled chimneys) 30° (2 pce) 15° (2 pce)	60	80	100
④ Inspection piece, straight (1 pce)	60	80	100
⑤ Balanced flue inspection piece, straight (1 pce)	60	80	100
⑥ Balanced flue wall bezel	60	80	100
⑦ Balanced flue pipe 1 m long 0.5 m long	60	80	100
⑧ Balanced flue bend 87° (1 pce) 45° (2 pce) or Balanced flue inspection tee 87° (1 pce) Balanced flue inspection bend 87° (1 pce)	60	80	100
⑨ Balanced flue sliding coupling	60	80	100
Fixing clamp, white (1 pce)	60	80	100
Stainless steel extension, (metal/PPs, rigid) 380 mm long for duct cover (for system size 60, an extension Ø 60 mm to Ø 80 mm is required)	60	80	100
Balanced flue adaptor – Ø 80/125 mm to Ø 60/100 mm – Ø 60/100 mm to Ø 80/125 mm – Ø 80/125 mm to Ø 100/150 mm	60 60 —	80 80 80	— — 100

Design and sizing information for connection on the flue gas side (cont.)

Max. total length of the flue up to the boiler flue connection

Vitodens 200-W, 222-F, 222-W and 242-F

Rated output range	kW	4.8–19.0	6.5–26.0	8.8–35.0	13.0–45.0	17.0–60.0	30.0–80.0	30.0–105.0
max. length - system size 60	m	20	20	15	—	—	—	—
max. length - system size 80	m	25 ^{*1}	25 ^{*1}	25 ^{*1}	20	15	—	—
max. length - system size 100	m	—	—	—	25 ^{*1}	20 ^{*1}	20	20

Vitodens 300-W, 333-F and 343-F

Rated output range	kW	3.8–13.0	3.8–19.0	5.2–26.0	7.0–35.0
max. length - system size 60	m	15	15	—	—
max. length - system size 80	m	17 ^{*1}	17 ^{*1}	20	15
max. length - system size 100	m	—	—	25 ^{*1}	20 ^{*1}

The following are taken into consideration:

2 x 87° bends (incl. support bends)

or

3 x 45° bends,

0.5 m length of connecting piece (D) and the following internal duct dimensions:

- 113 x 113 mm for system size 60
- 135 x 135 mm for system size 80
- 170 x 170 mm for system size 100

For a different number of bends, deduct from or add to the given max. length 1 m for 87° bends, 0.5 m for 45° bends or 2 m for inspection tees.

For a different length of connecting piece (D) deduct or add twice the respective difference.

Example:

Vitodens 300-W, 5.2 - 26.0 kW with 3 bends 87° and 2 m length of connecting piece (D):

Deduct 1 m for the bend and 3 m for the connecting piece from the max. flue length of 20 m. The max. length would then be 16 m.

Vitodens in conjunction with solid fuel boilers

Routing the flue pipe in a twin-draught duct.

The plastic flue pipe can be routed together with the flue pipe from a solid fuel boiler inside a twin-flue chimney. The following conditions are met:

Open flue operation or the ventilation air is not supplied through the duct

The terminals of inflammable flue pipes should, for fire safety reasons, be located approx. 400 mm below the duct outlet and for hardly inflammable flues approx. 300 mm below the duct terminal made from non-combustible materials.

Balanced flue operation – the ventilation air is supplied through the duct

Design the balanced flue terminals so that flue gas will not be drawn into the air duct in dangerous volumes and that pressure fluctuations due to wind influence affect the balanced flue system as evenly as possible.

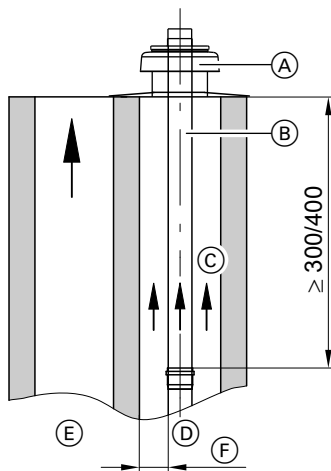

- (A) Metal duct cover
- (B) Terminal made from non-combustible material
- (C) Secondary ventilation
- (D) Vitodens flue
- (E) Chimney for solid fuel boilers
- (F) Minimum clearance to DIN 18160 (see page 11)

5414 641 GB

*1 Alternative system size: order balanced flue adaptor separately.

Design and sizing information for connection on the flue gas side (cont.)

■ When using a plastic duct cover:

The chimney for solid fuel boilers must protrude at least 1000 mm above the Vitodens flue. For the chimney extension, only use components that are resistant to soot fires.

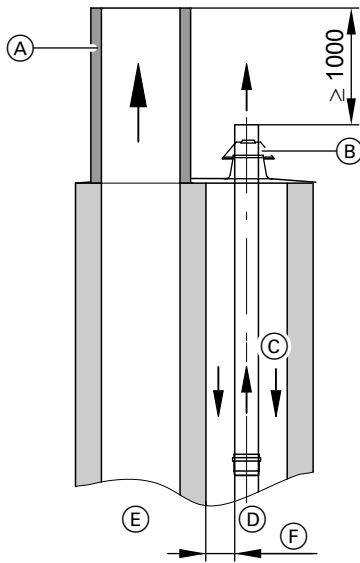

- (A) Chimney extension made from a soot fire-resistant material
- (B) Duct cover, plastic
- (C) Ventilation/secondary air
- (D) Vitodens flue
- (E) Chimney for solid fuel boilers
- (F) Minimum clearance to DIN 18160 (see page 11)

■ When using a metal duct cover:

The chimney for solid fuel boilers must protrude at least $2 \times \varnothing D$ above the Vitodens flue. For the chimney extension, only use components that are resistant to soot fires.

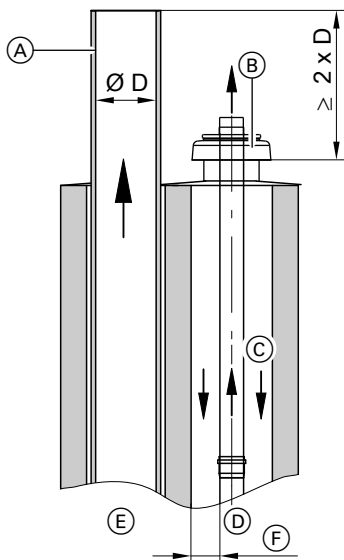

- (A) Chimney extension made from a soot fire-resistant material
- (B) Metal duct cover

- (C) Ventilation/secondary air
- (D) Vitodens flue (rigid or flexible)
- (E) Chimney for solid fuel boilers
- (F) Minimum clearance to DIN 18160 (see page 11)

■ When using a common down-draught plate:

The flue terminal and the duct cover must be made from non-combustible material (e.g. metal).

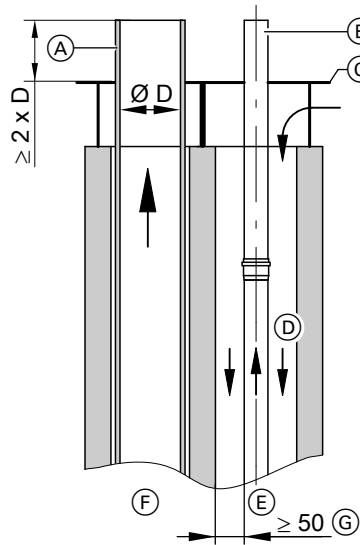

- (A) Chimney extension made from a soot fire-resistant material
- (B) Terminal made from non-combustible material
- (C) Duct cover (on-site)
- (D) Ventilation/secondary air
- (E) Vitodens flue
- (F) Chimney for solid fuel boilers
- (G) Minimum clearance to DIN 18160 (see page 11)

The metal terminal pipe and duct cover are part of the basic duct pack (metal/PPs).

The basic duct pack (metal/PPs) is available as an accessory.

Design and sizing information for connection on the flue gas side (cont.)

Flue, flexible, system size 60, 80 and 100 (components) (type C_{63x} according to TRGI 2008)

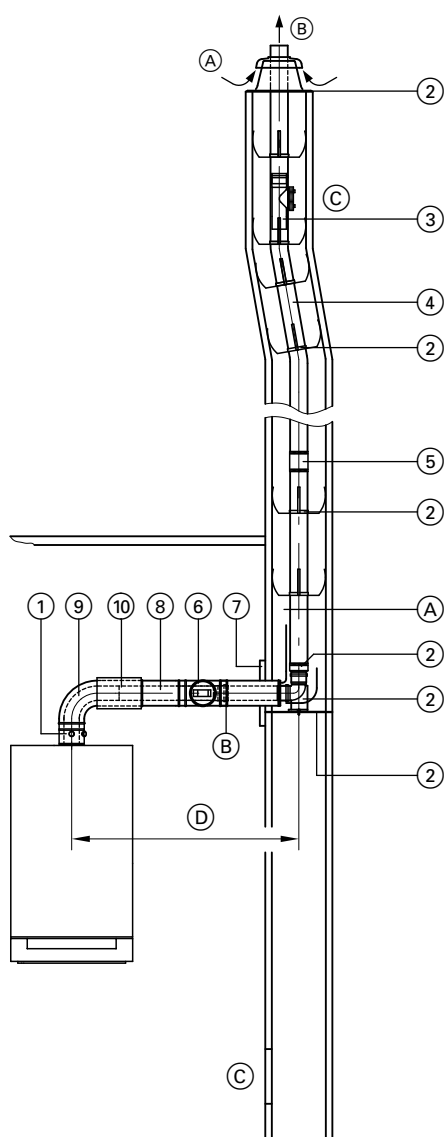

- (A) Ventilation air
- (B) Flue gas
- (C) Inspection aperture
- (D) Connecting piece

Note

The flexible flue pipe must only be routed vertically.

	System size Ø mm		
	60	80	100
① Boiler flue connection (part of the standard boiler delivery)	60	80	100
② Standard duct set (PPs, flexible) Comprising: – Support bend – Support rail – Duct cover – Spacers (5 pce, max. distance 2 m)	60	80	100
Standard duct set (metal/PPs, flexible) for twin-flue chimneys; one for solid fuel boilers Comprising: – Support bend – Support rail – Duct cover – Terminal pipe (stainless steel) – Spacers (5 pce, max. distance 2 m)	60	80	100
Spacers (5 pce, max. distance 2 m)	60	80	100
③ Inspection piece , straight for installation into the flexible flue pipe	60	80	100
④ Flue, flexible , as 8/12, 5/15 or 25 m rolls	60	80	100
⑤ Connecting piece for connecting residual lengths of the flexible flue	60	80	100
Pipe lowering attachment with 20 m rope	60	80	100
⑥ Balanced flue inspection piece , straight (1 pce)	60	80	100
⑦ Balanced flue wall bezel	60	80	100
⑧ Balanced flue pipe 1 m long 0.5 m long	60	80	100
⑨ Balanced flue bend 87° (1 pce) 45° (2 pce) or Balanced flue inspection tee 87° (1 pce) Balanced flue inspection bend 87° (1 pce)	60	80	100
⑩ Balanced flue sliding coupling	60	80	100
Fixing clamp , white (1 pce)	60	80	100
Stainless steel extension , (metal/PPs, flexible) 380 mm long for duct cover (for system size 60, an extension Ø 60 mm to Ø 80 mm is required)	60	80	100
Balanced flue adaptor – Ø 80/125 mm to Ø 60/100 mm – Ø 60/100 mm to Ø 80/125 mm – Ø 80/125 mm to Ø 70/110 mm – Ø 80/125 mm to Ø 100/150 mm	60 60 — —	80 80 80 80	— — — 100

Max. total flue length up to the boiler flue connection with flexible flue pipe

Vitodens 200-W, 222-F, 222-W and 242-F

Rated output range	kW	4.8–19.0	6.5–26.0	8.8–35.0	13.0–45.0	17.0–60.0	30.0–80.0	30.0–105.0
max. length - system size 80	m	16 ^{*1}	16 ^{*1}	16 ^{*1}	20	15	—	—
max. length - system size 100	m	—	—	—	22 ^{*1}	17 ^{*1}	20	20

5414 641 GB

^{*1} Alternative system size: order balanced flue adaptor separately.

Design and sizing information for connection on the flue gas side (cont.)

Vitodens 300-W, 333-F and 343-F

Rated output range	kW	3.8–13.0	3.8–19.0	5.2–26.0	7.0–35.0
max. length - system size 60	m	14	14	—	—
max. length - system size 80	m	16 ^{*1}	16 ^{*1}	18	13
max. length - system size 100	m	—	—	20 ^{*1}	15 ^{*1}

The following are taken into consideration:

2 x 87° bends (incl. support bends)

or

3 x 45° bends,

0.5 m length of connecting piece (D) and an internal duct dimension of 150 x 150 mm.

For a different number of bends, deduct from or add to the given max. length 1 m for 87° bends, 0.5 m for 45° bends or 2 m for inspection tees.

For a different length of connecting piece (D) deduct or add twice the respective difference.

Example:

Vitodens 300-W, 5.2 - 26.0 kW with 3 bends 87° and 2 m length of connecting piece (D):

Deduct 1 m for the bend and 3 m for the connecting piece from the max. flue length of 15 m. The max. length would then be 11 m.

2.2 Plastic (PPs) balanced flue system for vertical routing through a pitched or flat roof (type C_{33x} to TRGI 2008)

For vertical roof outlets when the Vitodens is installed in attics

The roof outlet may only be used, where the ceiling of the occupied room also forms part of the roof or only the roof structure is located above the ceiling (pitched attic).

Note

Install condensing boilers with an output > 50 kW in a separate and ventilated installation location (according to FeuVo [Germany]) (Vitodens 200-W from 60 kW).

When the balanced flue system is routed through roof spaces that are not used as accommodation, run the balanced flue pipe through an additional metal pipe as protection against mechanical damage (TRGI 2008).

It may also be routed behind a jamb wall or a solid wall of an attic built as accommodation, if the fire protection class of the jamb wall corresponds to that of the ceiling (e.g. B30).

Minimum clearances to combustible materials inside the installation location or in connection with the roof outlet are **not** required.

It was verified as part of the CE approval test that nowhere on the Vitodens or its balanced flue system will surface temperatures exceed 85 °C.

	Internal diameter Ø in mm	
	Flue pipe	Ventilation air pipe
Vitodens 200-W up to 35 kW, Vitodens 222-F, Vitodens 222-W, Vitodens 242-F, Vitodens 300-W and 333-F, up to 19 kW and Vitodens 343-F	60	100
Vitodens 200-W, 45 to 60 kW, Vitodens 300-W, 26 to 35 kW and Vitodens 333-F, 26 kW	80	125
Vitodens 200-W, 80 to 105 kW	100	150

For bends, deduct 1 m from the max. extended pipe length for 87° bends or 0.5 m for 45° bends.

Install an inspection aperture for checking and cleaning the flue pipe inside the installation room.

The vertical roof outlet has been tested and CE-designated as a concentric balanced flue system as one structural unit with the Vitodens condensing boiler.

A function verification according to EN 13384 is **not** required.

Vertical flat roof outlet

Integrate the flat roof collar into the roof skin according to the flat roof guidelines (see page 50). Push the roof outlet into the roof from above and position it on the flat roof collar.

Note

The ceiling opening should have a diameter of at least the specified size:

- System size Ø 60 mm: 105 mm
- System size Ø 80 mm: 130 mm
- System size Ø 100 mm: 160 mm

Secure the roof outlet on site with a clamp after the installation has been completed.

Maintain minimum clearances of 1.5 m towards each other and other components in accordance with FeuVo [Germany], when installing several vertical roof outlets adjacent to each other.

Note

Separate extensions are available (see table) if the length of 400 mm above the roof line and vertical to the roof surface is insufficient because of specific requirements. Approval with the flue system is ensured.

*1 Alternative system size: order balanced flue adaptor separately.

Design and sizing information for connection on the flue gas side (cont.)

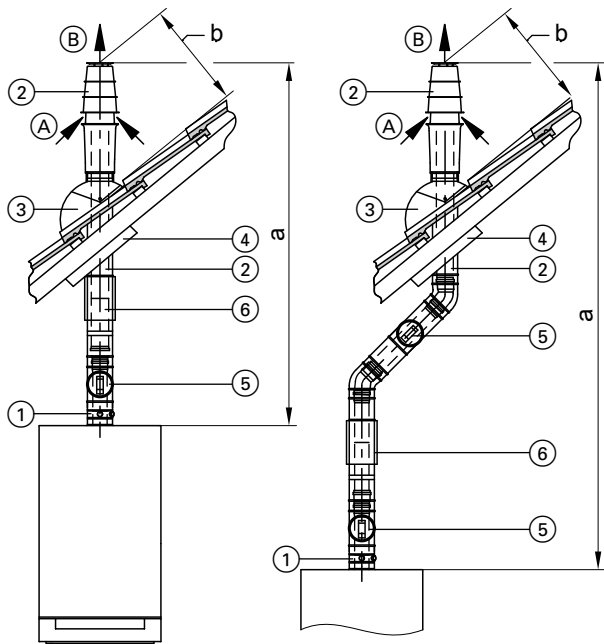

- (A) Ventilation air
(B) Flue gas

	System size Ø mm		
	60	80	100
① Boiler flue connection (part of the standard boiler delivery)	60	80	100
② Balanced flue roof outlet with fixing clamp Colour: black or Colour: terracotta Above-roof extension with clamp (brace on site) Colour: black 0.5 m long 1 m long, with bracing clamp Colour: terracotta 0.5 m long 1 m long, with bracing clamp	60	80	100
③ Universal roof tile – for slate and tile cover – colour: black or terracotta – for plain tile, slate and other covers – colour: black or terracotta or Flat roof collar or Pipe outlet for Klöber roof tiles Colour: black or terracotta (order the corresponding Klöber tile on site to match the roof cover selected for the roof outlet)	60	80	100
④ Universal cover plate	60	80	100
⑤ Balanced flue inspection piece, straight (1 pce)	60	80	100
⑥ Balanced flue sliding coupling	60	80	100
Balanced flue bend 87° (1 pce) 45° (2 pce)	60	80	100
Balanced flue pipe 1 m long 0.5 m long	60	80	100
Fixing clamp, white (1 pce)	60	80	100
Balanced flue adaptor – Ø 80/125 mm to Ø 60/100 mm – Ø 60/100 mm to Ø 80/125 mm – Ø 80/125 mm to Ø 100/150 mm	60 60 —	80 80 80	— — 100

Max. total length of the flue pipe

Vitodens 200-W, 222-F, 222-W and 242-F

Rated output range		kW	4.8–19.0	6.5–26.0	8.8–35.0	13.0–45.0	17.0–60.0	30.0–80.0	30.0–105.0
a	max. length - system size 60	m	10	10	10	—	—	—	—
a	max. length - system size 80	m	13 ^{*1}	13 ^{*1}	11 ^{*1}	10	6	—	—
a	max. length - system size 100	m	—	—	—	13 ^{*1}	9 ^{*1}	15	15
b	min.	mm	400	400	400	400	1000	1000	1000

Vitodens 300-W, 333-F and 343-F

Rated output range		kW	3.8–13.0	3.8–19.0	5.2–26.0	7.0–35.0
a	max. length - system size 60	m	10	10	—	—
a	max. length - system size 80	m	13 ^{*1}	13 ^{*1}	10	8
a	max. length - system size 100	m	—	—	13 ^{*1}	11 ^{*1}
b	min.	mm	400	400	400	400

5414 641 GB

*1 Alternative system size: order balanced flue adaptor separately.

Design and sizing information for connection on the flue gas side (cont.)

2.3 Plastic (PPs) balanced flue system for external wall outlets (type C_{13x} to TRGI 2008)

It was verified as part of the CE approval test that nowhere on the Vitodens or its balanced flue system will surface temperatures exceed 85 °C.

Observe the implementation information to TRGI 2008, in particular the arrangement/position of the wall outlet.

Install the connecting line with a slope of at least 3° towards the boiler.

For bends, deduct 1 m from the max. extended pipe length for 87° bends or 0.5 m for 45° bends.

Install an inspection aperture for checking and cleaning the flue pipe. The external wall outlet has been tested and CE-designated as a concentric balanced flue system as one structural unit with the Vitodens condensing boiler.

A function verification according to EN 13384 is **not** required.

2

	Internal diameter Ø in mm	
	Flue pipe	Ventilation air pipe
Vitodens 200-W up to 35 kW, Vitodens 222-F, Vitodens 222-W, Vitodens 242-F, Vitodens 300-W and 333-F, up to 19 kW and Vitodens 343-F	60	100
Vitodens 300-W, 26 to 35 kW and Vitodens 333-F, 26 kW	80	125

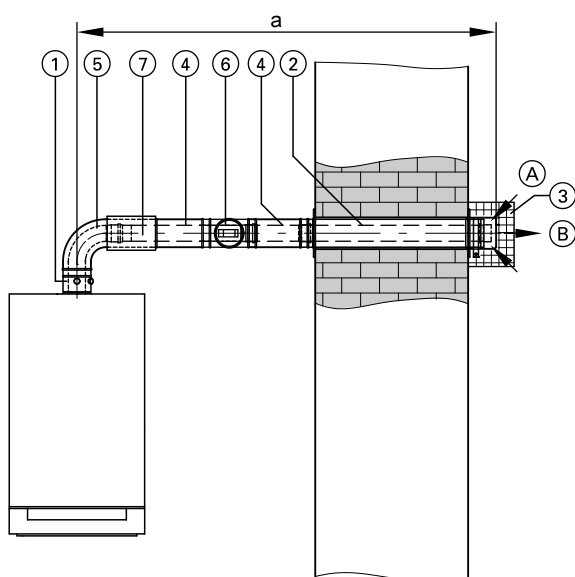

- (A) Ventilation air
(B) Flue gas

		System size Ø mm	
		60	80
①	Boiler flue connection (part of the standard boiler delivery)	60	80
②	Balanced flue external wall terminal (incl. wall bezels)	60	80
③	Protective grille required, if the combustion air inlet and flue outlet lie at a height of up to 2 m above ground level in areas of public or private traffic	60	80
④	Balanced flue pipe 1 m long 0.5 m long	60	80
⑤	Balanced flue bend 87° (1 pce) 45° (2 pce) or Balanced flue inspection bend , 87° (1 pce)	60	80
⑥	Balanced flue inspection piece , straight (1 pce)	60	80
⑦	Balanced flue sliding coupling	60	80
	Fixing clamp , white (1 pce)	60	80
	Balanced flue adaptor – Ø 80/125 mm to Ø 60/100 mm – Ø 60/100 mm to Ø 80/125 mm	60 60	80 80

Max. total length of the flue pipe

Vitodens 200-W, 222-F, 222-W and 242-F

Rated output range	kW	4.8–19.0	6.5–26.0	8.8–35.0	13.0–45.0	17.0–60.0	30.0–80.0	30.0–105.0
a max. length - system size 60	m	10	10	8	—	—	—	—
a max. length - system size 80	m	13 ^{*1}	13 ^{*1}	11 ^{*1}	10	10	—	—
a max. length - system size 100	m	—	—	—	13 ^{*1}	13 ^{*1}	13	13

Vitodens 300-W, 333-F and 343-F

Rated output range	kW	3.8–13.0	3.8–19.0	5.2–26.0	7.0–35.0
a max. length - system size 60	m	10	10	—	—
a max. length - system size 80	m	13 ^{*1}	13 ^{*1}	10	10
a max. length - system size 100	m	—	—	13 ^{*1}	13 ^{*1}

*1 Alternative system size: order balanced flue adaptor separately.

Design and sizing information for connection on the flue gas side (cont.)

2.4 Plastic (PPs) balanced flue system for routing over external walls (type C_{53x} to TRGI 2008)

The Vitodens may also be connected, without a duct, to a flue pipe routed over an external wall.

The combustion air is drawn in via the air inlet piece. The vertical external pipe acts as protection and the static air inside acts as thermal insulation.

	Internal diameter Ø in mm	
	Flue pipe	Ventilation air pipe
Vitodens 200-W up to 35 kW, Vitodens 222-F, Vitodens 222-W, Vitodens 242-F, Vitodens 300-W and 333-F, up to 19 kW and Vitodens 343-F	60	100
Vitodens 200-W, 45 to 60 kW, Vitodens 300-W, 26 to 35 kW and Vitodens 333-F, 26 kW	80	125
Vitodens 200-W, 80 to 105 kW	100	150

The external wall flue has been tested and CE-designated as a concentric balanced flue system as one structural unit with the Vitodens condensing boiler. A function verification according to EN 13384 is **not** required.

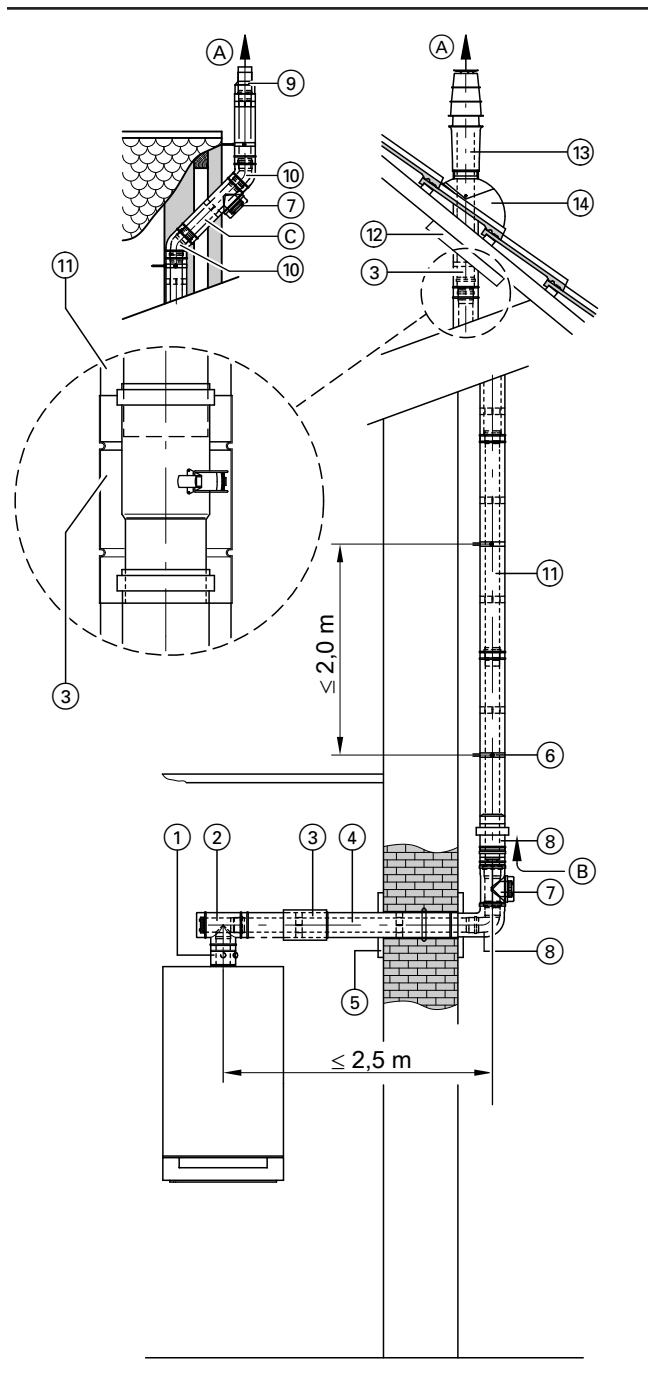

- (A) Flue gas
- (B) Ventilation air
- (C) Step in the external wall flue, see page 40

2

Design and sizing information for connection on the flue gas side (cont.)

	System size Ø mm		
	60	80	100
① Boiler flue connection (part of the standard boiler delivery)			
② Balanced flue inspection tee 87° (1 pce)	—	—	100
Balanced flue inspection bend , 87° (1 pce) or Balanced flue inspection piece , straight (1 pce) and Balanced flue bend 87° (1 pce)	60	80	100
③ Balanced flue sliding coupling	60	80	100
④ Balanced flue pipe 1.95 m long (1 pce) 1 m long (1 pce) 0.5 m long (1 pce)	60	80	100
⑤ Wall bezel	60	80	100
⑥ Fixing clamp , white (1 pce)	60	80	100
⑦ Balanced flue inspection piece , straight (1 pce) or External wall inspection piece , straight (1 pce)	60	80	100
⑧ External wall pack Comprising: – Balanced flue bend – Balanced flue air intake – Wall bezel	60	80	100
⑨ External wall terminal for a short roof overhang	60	80	100
⑩ Balanced flue bend 87° (1 pce) 45° (2 pce) or	60	80	— —

	System size Ø mm		
	60	80	100
External wall bend 87° (1 pce) 45° (2 pce)	—	—	100 100
⑪ Balanced flue pipe 1.95 m long (1 pce) 1 m long (1 pce) 0.5 m long (1 pce) or External wall pipe 1.95 m long (1 pce) 1 m long (1 pce) 0.5 m long (1 pce)	60	80	— — — 100 100 100
⑫ Universal cover plates	60	80	100
⑬ Balanced flue roof outlet External wall with fixing clamps (for a high roof overhang) Colour: black or terracotta Above-roof extension with clamp (brace on site) Colour: black 0.5 m long 1 m long Colour: terracotta 0.5 m long 1 m long	60	80	100 — — 100 100 100
⑭ Universal roof tile – for slate and tile cover. Colour: black or terracotta – for plain tile, slate and other covers. Colour: black or terracotta Pipe outlet for Klöber roof tiles Colour: black or terracotta (order the corresponding Klöber tile on site to match the roof cover selected for the roof outlet)	60	80	100 100 —
Balanced flue adaptor – Ø 80/125 mm to Ø 60/100 mm – Ø 60/100 mm to Ø 80/125 mm – Ø 80/125 mm to Ø 100/150 mm	60	80	— — 100

Max. total length of the flue pipe

Vitodens 200-W, 222-F, 222-W and 242-F

Rated output range	kW	4.8–19.0	6.5–26.0	8.8–35.0	13.0–45.0	17.0–60.0	30.0–80.0	30.0–105.0
max. length - system size 60	m	20	20	15	—	—	—	—
max. length - system size 80	m	25 ^{*1}	25 ^{*1}	20 ^{*1}	12	12	—	—
max. length - system size 100	m	—	—	—	17 ^{*1}	17 ^{*1}	20	20

Vitodens 300-W, 333-F and 343-F

Rated output range	kW	3.8–13.0	3.8–19.0	5.2–26.0	7.0–35.0
max. length - system size 60	m	12	12	—	—
max. length - system size 80	m	15 ^{*1}	15 ^{*1}	15	12
max. length - system size 100	m	—	—	17 ^{*1}	15 ^{*1}

The following are taken into consideration:

2 x 87° bends (incl. support bends)

or

3 x 45° bends

and 1.0 m length of connecting piece ⑩.

For a different number of bends, deduct from or add to the given max. length 1 m for 87° bends or 0.5 m for 45° bends.

For a different length of connecting piece ⑩, deduct or add the difference respectively.

Example:

Vitodens 300-W, 5.2 - 26.0 kW, with 3 x 87° bends and 3 m length of connecting piece ⑩:

Deduct 1 m for the bend and 0.5 m for the connecting piece from the max. flue length of 15 m.

The max. length would then be 13.5 m.

*1 Alternative system size: order balanced flue adaptor separately.

Design and sizing information for connection on the flue gas side (cont.)

2.5 Plastic (PPs) balanced flue system for routing through a lightweight duct

A space-saving duct for reduced temperature requirements may be retrofitted if no duct is available in location where the Vitodens is installed with one or more full storeys above.

The duct must comply with the requirements for domestic chimneys to DIN 18160-1 or must have general Building Regulation approval.

"UNIFIX" duct profiles offered by Skoberne (made from aerated concrete)

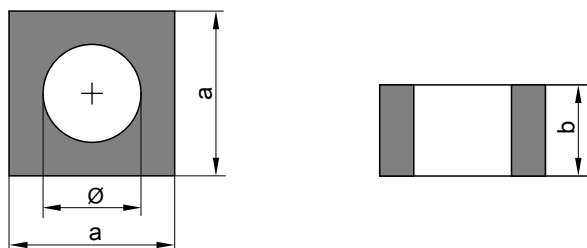

Ø mm	a mm	b mm	Fire rating
165	240	500	90 min
210	300	500	90 min
240	360	249	90 min
280	400	249	90 min

"SKOBIFIXnano" and "SKOBIFIXs 30" duct profiles offered by Skoberne (made from foamed ceramics)

Fire rating 30 min.

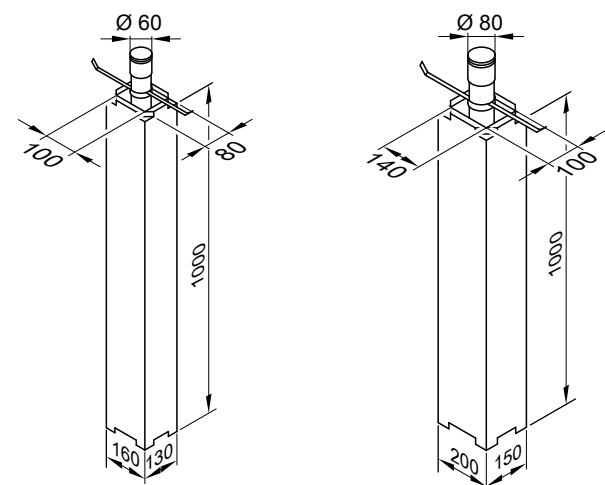

Skoberne offer a duct system made from breeze concrete or foamed ceramics with general Building Regulations approval [Germany].

Address for Skoberne:
Skoberne Schornsteinsysteme GmbH
Ostendstraße 1
D-64319 Pfungstadt

Anchoring for roof outlets with duct profiles

(where the duct is run up to the roof skin)

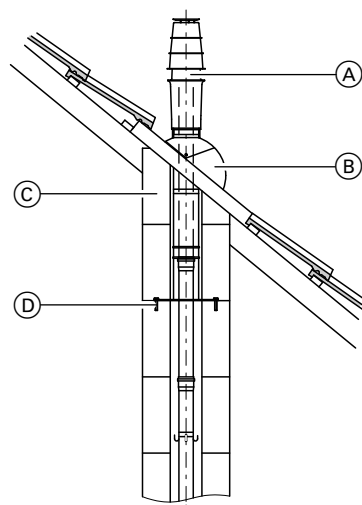

Available from Skoberne:

- (A) Roof outlet
- (B) Universal roof tile
- (C) Terminal duct profile
- (D) Anchoring of the roof outlet

During installation, match the terminal duct profile (C) to the roof pitch.

Design and sizing information for connection on the flue gas side (cont.)

Promat duct profiles

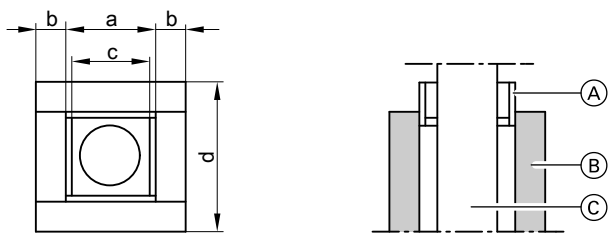

Amongst others, Promat offer a duct system made from calcium silicate fire resistant plates with general Building Regulations approval [Germany].

Address for Promat:
Promat GmbH
Postfach 109 564
D-40835 Ratingen

2

- (A) PROMATECT® female connection
- (B) PROMATECT® profile
- (C) Flue

System size Ø mm	a mm	b mm	c mm	d mm	Fire rating
80	140	25	128	190	30 min
	140	40	128	220	90 min
100	180	25	168	230	30 min
	180	40	168	260	90 min

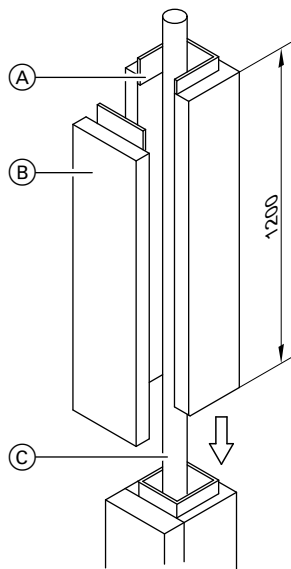

- (A) PROMATECT® female connection
- (B) PROMATECT® profile
- (C) Flue

Design and sizing information for connection on the flue gas side (cont.)

Roof outlet for ducts with Promat profiles

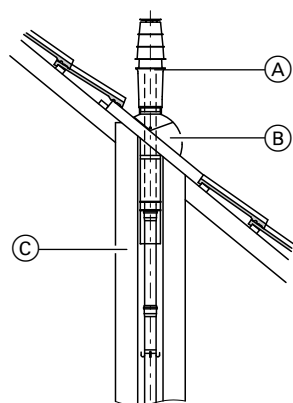

During installation, match the final duct profile to the roof pitch.

- (A) Vertical coaxial roof outlet (balanced flue system)
- (B) Universal roof tile
- (C) Lightweight duct made from PROMATECT® mineral fibre profiles

2.6 Plastic (PPs) balanced flue system for routing multiple pipes through a duct

There is an option of routing several flues in balanced flue mode through a common, sufficiently sized duct. For this, the Vitodens must be installed in the same occupied space. For reasons of fire protection, the installation and connection on different levels or in different rooms is not possible. The flues and the duct covers must be professionally supported inside/on the duct. For balanced flue components from the Vitodens to the common duct, see page 12.

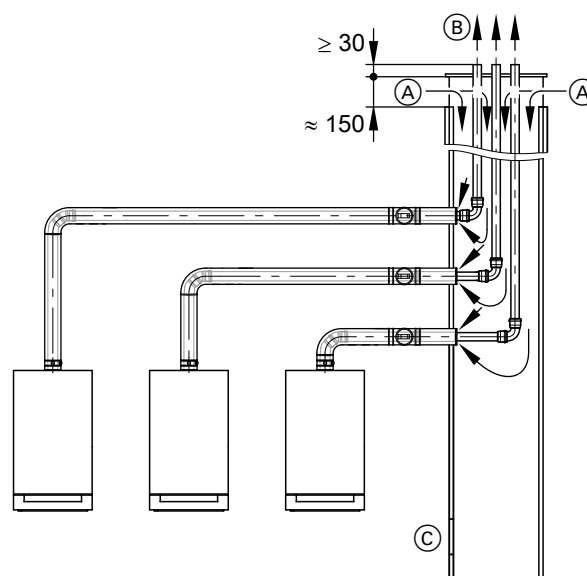

- (A) Ventilation air
- (B) Flue gas
- (C) Inspection aperture

Layout examples

Minimum clearances of the individual flues in accordance with DIN 18160-1:

- In square/rectangular ducts: 20 mm
- In round ducts: 30 mm

Design and sizing information for connection on the flue gas side (cont.)

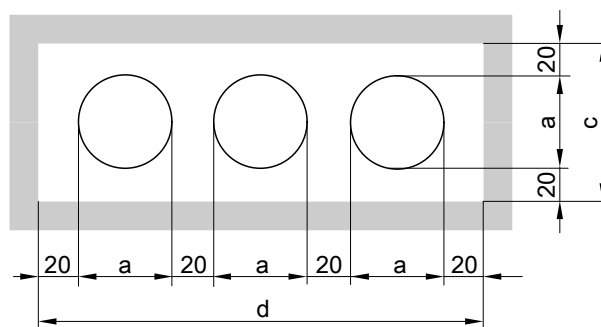
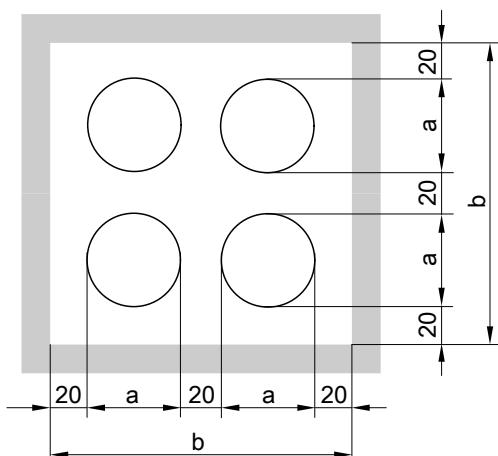

System size Ø mm	Dimension [mm]			
	a	b	c	d
60	73	206	113	299
80	94	248	134	362
100	128	316	168	464

Note

According to the approval certificate, internal duct dimensions smaller than those shown in the table may also be used, if this is indicated by the function verification to DIN EN 13384.

2.7 Plastic (PPs) balanced flue system (connecting line) for connecting multiple flues to a single room sealed balanced flue

The Vitodens condensing boilers meet the safety requirements in accordance with DIN 3368-6. Therefore, a general Building Regulations approval for connection to a room sealed balanced flue is not required.

When connecting two condensing boilers to one chimney on the same floor, the connecting piece inlets should be separated by at least 300 mm.

Design and calculations for room sealed balanced flue systems with multiple flues are carried out by the relevant manufacturer.

Design and sizing information for connection on the flue gas side (cont.)

Room sealed balanced flue, negative pressure (type C_{43x} to TRGI 2008)

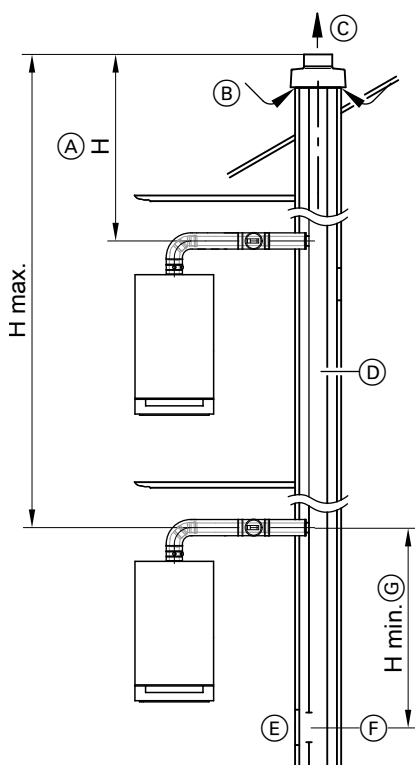

- Ⓒ Flue gas
- Ⓓ Room sealed balanced flue (see below for manufacturers)
- Ⓔ Inspection aperture
- Ⓕ Pressure balancing aperture
- Ⓖ Check with the flue gas system manufacturer regarding minimum clearances.

Room sealed balanced flue systems for negative pressure may, for example, be obtained from the following manufacturers:

- eka Edelstahlkamin GmbH
D-95369 Untersteinach
- Jeremias
Schornstein Systeme
Opfenrieder Str. 12
D-91717 Wassertrüdingen
- Plewa-Werke GmbH
D-54662 Speicher/Eifel
- Schiedel GmbH & Co, Hauptverwaltung
Lerchenstraße 9
D-80995 München

- Ⓐ Effective chimney height relative to the highest Vitodens
- Ⓑ Ventilation air

Room sealed balanced flue, positive pressure – multiple connection with the Vitodens 200-W (type C_{43x} to TRGI 2008)

System for balanced flue operation, specifically developed for the Vitodens 200-W.

Minimum duct cross-section:

- 175 x 175 mm square
- Ø 195 mm round.

Up to 5 Vitodens 200-W (up to 26 kW) with the same rated output can be connected to one flue gas system. Vitodens with different rated outputs can only be connected to flue gas systems with negative pressure operation.

Design and sizing information for connection on the flue gas side (cont.)

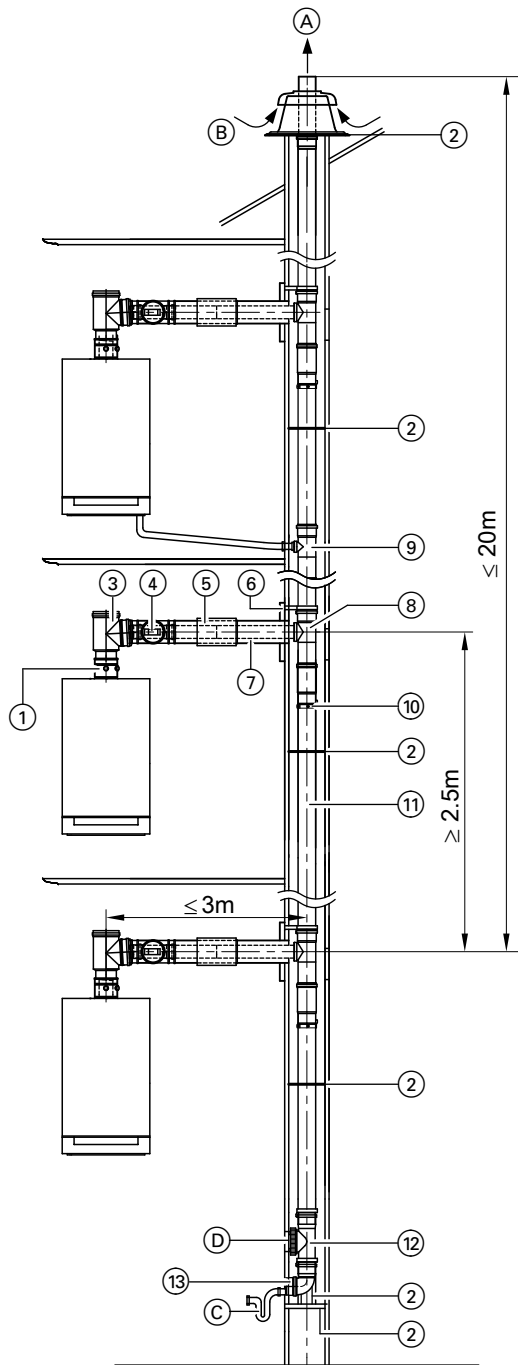

- (A) Flue gas
- (B) Ventilation air
- (C) Condensate drain with siphon
- (D) Inspection aperture

		System size Ø mm	
①	Boiler flue connection (part of the standard boiler delivery)	80	—
	Balanced flue adaptor Ø 60/100 mm to Ø 80/125 mm (required only for the Vitodens 200-W, 4.8 - 19.0 kW)	80	—
②	Standard duct set (PPs, rigid) Comprising: – Support bend – Support rail – Duct cover (PPs) – Spacers (3 pce)	—	100
	Spacers (3 pce)	—	100
③	Flue gas non-return device 87° (1 pce)	80	—
④	Balanced flue inspection piece, straight (1 pce)	80	—
⑤	Balanced flue sliding coupling	80	—
	Fixing clamp, white (1 pce) (balanced flue pipe)	80	—
⑥	Wall bezel	80	—
⑦	Balanced flue pipe 1 m long 0.5 m long	80 80	— —
⑧	Connecting assembly multiple connection Comprising: – Inspection pipe Ø 100 – Flue connection Ø 80 – Fixing clamp – Spacers – Long fem. connection Ø 100	—	100
⑨	Connecting assembly; condensate drain Comprising: – Branch 87° Ø 40 – Fixing clamp – Long fem. connection Ø 100	—	100
⑩	Connection clip required for every duct joint	—	100
⑪	Flue pipe 2 m long (2 pce @ 2 m = 4 m) 2 m long (1 pce) 1 m long (1 pce) 0.5 m long (1 pce)	— — — —	100 100 100 100
	Balanced flue bend 87° (1 pce) 45° (2 pce) or Balanced flue inspection bend 87° (1 pce)	80 80 80	— — —
	Flue bend (for use in corbelled ducts) 30° (2 pce) 15° (2 pce)	— —	100 100
⑫	Inspection piece, straight (1 pce)	—	100
⑬	Condensate drain connection (eccentric) Reducer from Ø 100 mm to Ø 40 mm	—	100

2.8 Plastic (PPs) flue pipe for routing through a duct with open flue operation (type B according to TRGI 2008)

Open flue operation requires a flue pipe as connecting piece between the Vitodens and the duct as well as for routing through the duct.

The installation room must provide a ventilation aperture with an open cross-section of at least 150 cm² or 2 × 75 cm² (according to TRGI 2008).

Design and sizing information for connection on the flue gas side (cont.)

Note

Install the Vitodens 200-W, from 60 kW, and multi-boiler systems in accordance with FeuVo [or local regulations] in a separate installation room with a suitable ventilation aperture. The cross-section should be at least 150 cm² and should be 2 cm² larger for each kW above 50 kW rated output. This cross-section may not be split over more than 2 apertures (observe your local fire regulations).

	Internal flue diameter Ø in mm
Vitodens 200-W up to 35 kW, Vitodens 222-F, Vitodens 222-W, Vitodens 242-F, Vitodens 300-W and 333-F, up to 19 kW and Vitodens 343-F	60
Vitodens 200-W, 45 to 60 kW, Vitodens 300-W, 26 to 35 kW and Vitodens 333-F, 26 kW	80
Vitodens 200-W, 80 to 105 kW	100

The flue gas system is connected to the boiler flue connection. The combustion air is drawn from the installation room via the annular gap in the boiler flue connection. For installation through ducts or channels with linear ventilation meeting the requirements for domestic chimney stacks to DIN 18160-1 or for a fire rating of 90 minutes (F90/L90), or a fire rating of 30 minutes (F30/L30) for low rise buildings. Prior to installation, the flue gas inspector should check that the duct to be used is suitable and approved for this purpose. Ducts that were previously connected to oil or solid fuel boilers must be thoroughly cleaned by a chimney sweep. Loose deposits comprising sulphur and soot must not remain on the inside of the chimney.

Close off and seal any other connection apertures with appropriate materials.

This does not apply to any cleaning or test apertures that are provided with chimney clean-out covers and that are identified with an appropriate test mark.

Check prior to installation whether the duct runs straight from top to bottom or if it is offset (check with mirrors).

If the chimney is offset, we recommend the installation of a flexible flue pipe (see page 29).

The local flue gas inspector should check the system for tightness prior to commissioning (where applicable).

In the case of **open** flue operation, this can **only** be done by means of a pressure test.

Inside the installation location, at least one inspection aperture must be provided in the flue system for checking and cleaning as well as for checking the pressure.

If the flue pipe is inaccessible from the roof, a second inspection aperture must be provided in the attic behind the chimney cleaning hatch. Safeguard the unrestricted draining of the condensate from the flue **into the boiler** through an appropriate **slope of at least 3°**.

Route the flue system to above the roof (observe the roof protrusion parallel to the roof inclination according to local regulations).

Alternative CE-designated flue pipes may be used, for example, if a larger flue pipe diameter is required, i.e. because of greater flue lengths. In that case, the function verification to EN 13384 should be provided by the relevant flue pipe manufacturer.

2

Minimum internal duct dimensions

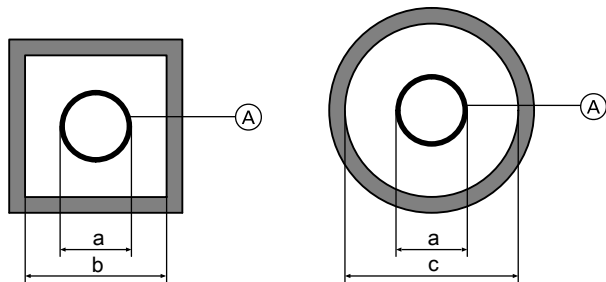

System size (A)	External diameter; fem. connection a	Minimum internal duct dimension	
	Ø mm	b square or rectangular (short side) mm	c round Ø mm
60	73	113	133
60 (flexible)	64	104	124
80	94	135	155
80 (flexible)	100	140	160
100	128	170	190
100 (flexible)	125	165	185

Max. number of bends:

- 87°: 3 pce
or
- 45°: 3 pce
or

- 30°: 4 pce
or
- 15°: 4 pce

The annular gap must be at least 3 cm wide at the duct inlet.

Design and sizing information for connection on the flue gas side (cont.)

Flue, system size 60, 80 and 100 (components) (type B₂₃ /B₃₃ according to TRGI 2008)

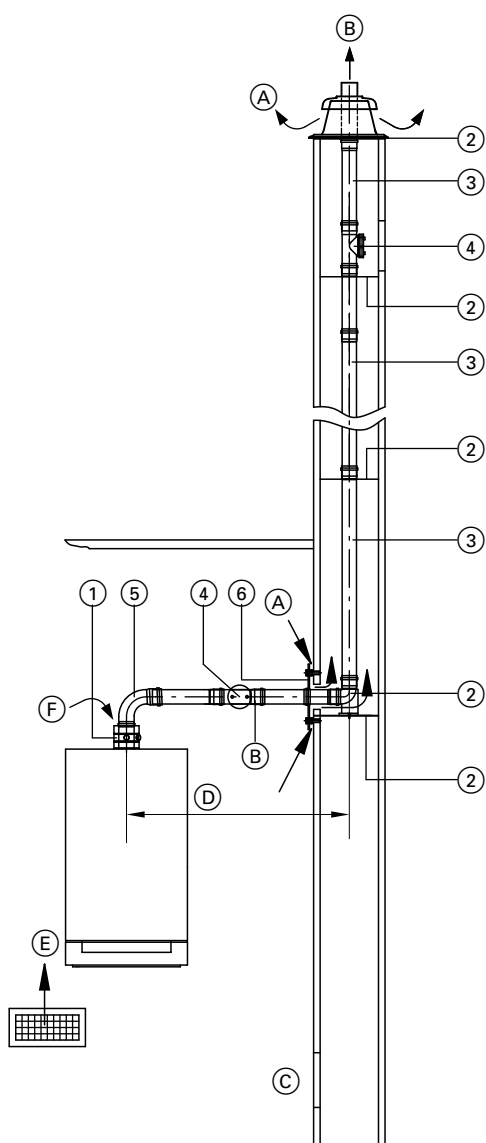

- (A) Secondary ventilation
- (B) Flue gas
- (C) Inspection aperture
- (D) Connecting piece
- (E) For sizing the ventilation air aperture, see page 27
- (F) Ventilation air

	System size Ø mm		
	60	80	100
① Boiler flue connection (part of the standard boiler delivery)	60	80	100
② Standard duct set (PPs, rigid) Comprising: – Support bend – Support rail – Duct cover – Spacers (3 pce, max. distance 5 m) or Standard duct pack (metal/PPs, rigid) for twin-draught chimneys; one draught for solid fuel boilers comprising: – Support bend – Support rail – Duct cover – Terminal pipe (stainless steel) – Spacers (3 pce, max. distance 5 m)	60	80	100
Spacers (3 pce, max. distance 5 m)	60	80	100
③ Flue pipe 1.95 m long (2 pce @ 1.95 m = 3.9 m) 1.95 m long (1 pce) 1 m long (1 pce) 0.5 m long (1 pce)	60	80	100
④ Inspection piece, straight (1 pce)	60	80	100
⑤ Flue bend 87° (1 pce) 45° (2 pce) or Inspection tee 87° (1 pce) or Inspection bend 87° (1 pce)	60	80	—
⑥ Ventilation bezel (1 pce) Flue bend (for use in corbelled chimneys) 30° (2 pce) 15° (2 pce) Stainless steel extension , (metal/PPs, rigid) 380 mm long for duct cover (for system size 60, an extension Ø 60 mm to Ø 80 mm is required)	60	80	100
Extension – Ø 60 mm to Ø 80 mm – Ø 80 mm to Ø 100 mm	60	80	—

Max. total length of the flue pipe

Vitodens 200-W, 222-F, 222-W and 242-F

Rated output range	kW	4.8–19.0	6.5–26.0	8.8–35.0	13.0–45.0	17.0–60.0	30.0–80.0	30.0–105.0
max. length - system size 60	m	20	20	15	—	—	—	—
max. length - system size 80	m	25 ^{*1}	25 ^{*1}	25 ^{*1}	25	15	—	—
max. length - system size 100	m	—	—	—	25 ^{*1}	20 ^{*1}	20	20

Vitodens 300-W, 333-F and 343-F

Rated output range	kW	3.8–13.0	3.8–19.0	5.2–26.0	7.0–35.0
max. length - system size 60	m	15	15	—	—
max. length - system size 80	m	17 ^{*1}	17 ^{*1}	20	15
max. length - system size 100	m	—	—	25 ^{*1}	20 ^{*1}

^{*1} Alternative system size: order balanced flue adaptor separately.

Design and sizing information for connection on the flue gas side (cont.)

The following are taken into consideration:

2 x 87° bends (incl. support bends)

or

3 x 45° bends

and 0.5 m length of connecting piece (D).

For a different number of bends, deduct from or add to the given max. length 1 m for 87° bends or 0.5 m for 45° bends.

For a different length of connecting piece (D), deduct or add the difference respectively.

Example:

Vitodens 300-W, 5.2 - 26.0 kW with 3 bends 87° and 1 m length of connecting piece (D):

Deduct 1 m for the bend and 0.5 m for the connecting piece from the max. flue length of 20 m.

The max. length would then be 18.5 m.

Flue, flexible, system size 60, 80 and 100 (components) (type B_{23x} according to TRGI 2008)

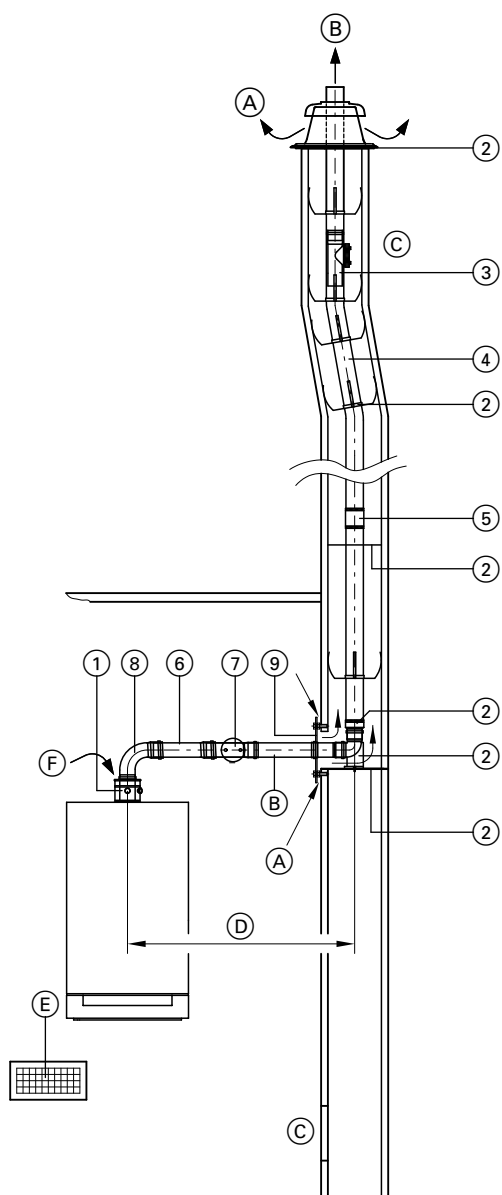

- (A) Secondary ventilation
- (B) Flue gas
- (C) Inspection aperture
- (D) Connecting piece
- (E) Ventilation air aperture, min. 150 cm² or 2 x 75 cm²
- (F) Ventilation air

Note

The flexible flue pipe must only be routed vertically.

	System size Ø mm		
	60	80	100
① Boiler flue connection (part of the standard boiler delivery)	60	80	100
② Standard duct set (PPs, flexible) Comprising: – Support bend – Support rail – Duct cover – Spacers (5 pce, max. distance 2 m)	60	80	100
Standard duct pack (metal/PPs, flexible) for twin-draught chimneys; one draught for solid fuel boilers Comprising: – Support bend – Support rail – Duct cover – Terminal pipe (stainless steel) – Spacers (5 pce, max. distance 2 m)	60	80	100
③ Spacers (5 pce, max. distance 2 m)	60	80	100
④ Inspection piece, straight for installation into the flexible flue pipe	60	80	100
⑤ Flue, flexible, as 8, 12.5 or 25 m rolls	60	80	100
⑥ Connecting piece for connecting residual lengths of the flexible flue	60	80	100
Pipe lowering attachment with 20 m rope	60	80	100
⑦ Flue pipe 1 m long (1 pce) 0.5 m long (1 pce)	60	80	100
⑧ Inspection piece, straight (1 pce)	60	80	100
⑨ Flue bend 87° (1 pce) 45° (2 pce) or Inspection tee 87° (1 pce) or Inspection bend 87° (1 pce)	60	80	80
⑩ Ventilation bezel (1 pce)	60	80	100
⑪ Stainless steel extension, (metal/PPs, flexible) 380 mm long for duct cover (for system size 60, an extension Ø 60 mm to Ø 80 mm is required)	60	80	100
⑫ Extension – Ø 60 mm to Ø 80 mm – Ø 80 mm to Ø 100 mm	60	80	– 100

Design and sizing information for connection on the flue gas side (cont.)

Max. total length of the flue pipe

Vitodens 200-W, 222-F, 222-W and 242-F

Rated output range	kW	4.8–19.0	6.5–26.0	8.8–35.0	13.0–45.0	17.0–60.0	30.0–80.0	30.0–105.0
max. length - system size 80	m	16 ^{*1}	16 ^{*1}	16 ^{*1}	20	15	—	—
max. length - system size 100	m	—	—	—	22 ^{*1}	17 ^{*1}	20	20

Vitodens 300-W, 333-F and 343-F

Rated output range	kW	3.8–13.0	3.8–19.0	5.2–26.0	7.0–35.0
max. length - system size 60	m	14	14	—	—
max. length - system size 80	m	16 ^{*1}	16 ^{*1}	18	13
max. length - system size 100	m	—	—	20 ^{*1}	15 ^{*1}

The following are taken into consideration:

2 x 87° bends (incl. support bends)

or

3 x 45° bends

and 0.5 m length of connecting piece (D).

For a different number of bends, deduct from or add to the given max. length 1 m for 87° bends or 0.5 m for 45° bends.

For a different length of connecting piece (D), deduct or add the difference respectively.

Example:

Vitodens 300-W, 5.2 - 26.0 kW with 3 bends 87° and 1 m length of connecting piece (D):

Deduct 1 m for the bend and 0.5 m for the connecting piece from the max. flue length of 18 m.

The max. length would then be 16.5 m.

Special types: Open flue operation with combustion air supply via interconnected rooms for the Vitodens up to 35 kW (type B₃₃ according to TRGI 2008)

The Vitodens may also be installed in occupied rooms and be operated in open flue mode, subject to the following conditions being met:

- The duct connecting piece is constructed as balanced flue pipe, and the combustion air is drawn directly from the room via an aperture at the chimney inlet (interconnected room air supply wall bezel, see page 40).
- As specified by the TRGI 2008, an adequate combustion air supply must be ensured inside the room through combustion air interconnection:
 - Minimum volume of the interconnected rooms, 4 m³ per kW rated output
 - Apertures in connecting doors min. 150 cm²

When routing through ducts, the same conditions apply as for the routing of flue gas systems through a duct, see page 26.

Calculation of the max. total flue length, see page 28.

*1 Alternative system size: order balanced flue adaptor separately.

Design and sizing information for connection on the flue gas side (cont.)

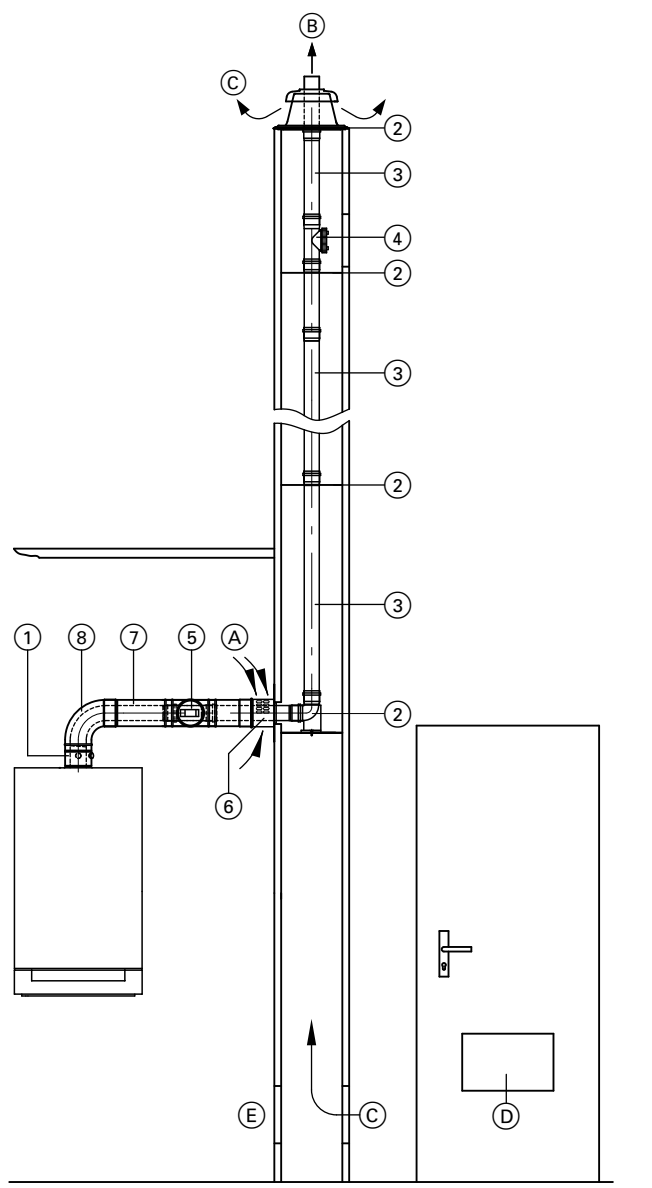

- (A) Ventilation air
- (B) Flue gas
- (C) Secondary ventilation
- (D) Aperture for interconnected room air supply (min. 150 cm²)
- (E) Inspection aperture

	System size Ø mm	
① Boiler flue connection (part of the standard boiler delivery)	60	80
② Standard duct set (PPs, rigid) Comprising: – Support bend – Support rail – Duct cover – Spacers (3 pce, max. distance 5 m) or Standard duct pack (metal/PPs, rigid) for twin-draught chimneys; one draught for solid fuel boilers comprising: – Support bend – Support rail – Duct cover – Terminal pipe (stainless steel) – Spacers (3 pce, max. distance 5 m)	60	80
Spacers (3 pce, max. clearance 5 m)	60	80
③ Flue pipe 1.95 m long (2 pce @ 1.95 m = 3.9 m) 1.95 m long (1 pce) 1 m long (1 pce) 0.5 m long (1 pce)	60	80
Flue bend (for use in corbelled chimneys) 30° (2 pce) 15° (2 pce)	60	80
④ Inspection piece, straight (1 pce)	60	80
⑤ Balanced flue inspection piece, straight (1 pce)	60	80
⑥ Balanced flue room interconnection bezel Ø 80/125 mm (type B ₃₃ to TRGI 2008)	60	80
⑦ Balanced flue pipe 1 m long 0.5 m long	60	80
⑧ Flue bend 87° (1 pce) 45° (2 pce) or Balanced flue inspection bend, 87° (1 pce)	60	80
Stainless steel extension, 380 mm long for duct cover (for system size 60, an extension Ø 60 mm to Ø 80 mm is required)	60	80

2

Connection to a moisture-resistant chimney (MR chimney negative pressure) with a plastic (PPs) flue pipe (type B_{23x}, according to TRGI 2008)

Vitodens condensing boilers may be connected to moisture-resistant chimney stacks to EN 13384, if the chimney manufacturer can verify its suitability based on the stated flue gas values considering local conditions (e.g. heating water return temperature, design of the pipe connecting piece, etc.).

A moisture-resistant flue that complies with Building Regulations should be used as a connecting piece. You may use the plastic flue gas system (PPs) offered as accessory to the Vitodens, for this purpose.

The adaptor from the flue pipe to the MR chimney must be purchased from the chimney manufacturer.

Design and sizing information for connection on the flue gas side (cont.)

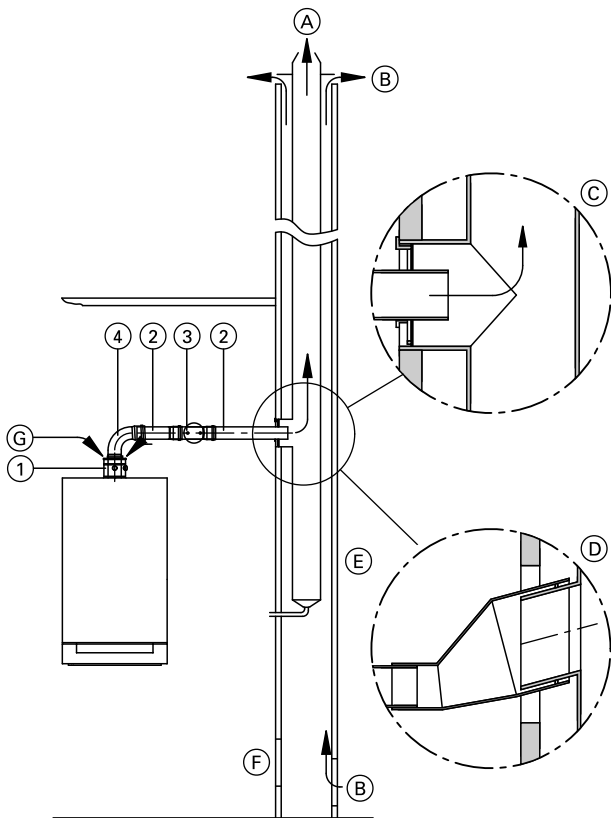

- (A) Flue gas
- (B) Secondary ventilation
- (C) For example: Plug-in adaptor by Schiedel
- (D) For example: Plug-in adaptor by Plewa
- (E) MR chimney
- (F) Inspection aperture
- (G) Ventilation air

		System size Ø mm		
①	Boiler flue connection (part of the standard boiler delivery)	60	80	100
②	Flue pipe			
	1.95 m long (2 pce @ 1.95 m = 3.9 m)	60	80	100
	1.95 m long (1 pce)	60	80	100
	1 m long (1 pce)	60	80	100
	0.5 m long (1 pce)	60	80	100
③	Inspection piece, straight (1 pce)	60	80	100
④	Flue bend	60	80	100
	87° (1 pce)			
	or Inspection tee	60	80	—
	87° (1 pce)			
	or Inspection bend	—	—	100
	87° (1 pce)			

Multi-boiler systems with flue gas systems operating with positive pressure (open flue operation) – Vitodens 200-W, 19 to 105 kW

Up to 4 gas condensing boilers, 19 to 105 kW, may be connected to a common pressurised flue. The max. output would be 420 kW. The Vitodens 200-W multi-boiler systems with common pressurised flue gas systems are designed for open flue operation (type B).

Installation requirements

Combustion air apertures

Gas equipment with a total rated output in excess of 50 kW must be provided with combustion air apertures leading to the outside. The cross-section should be at least 150 cm² and should be 2 cm² larger for each kW above 50 kW rated output. This cross-section may not be split over more than 2 apertures (observe your local fire regulations).

Example:

Vitodens 200-W, 3 × 80 kW

Total rated output 240 kW

$150 \text{ cm}^2 + ((240 \text{ kW} - 50 \text{ kW}) \times 2 \text{ cm}^2/\text{kW}) = 530 \text{ cm}^2$

or $2 \times 265 \text{ cm}^2$.

The combustion air apertures should be at least 530 cm² or $2 \times 265 \text{ cm}^2$.

Installation clearances

For a simple installation we recommend a clearance of approx. 100 to 150 mm between the gas condensing boilers. For multi-boiler systems in conjunction with a hydraulic cascade, this clearance must be 100 mm.

Flue gas non-return device

A flue gas non-return device is installed above each boiler, i.e. in the area of the header.

During the boiler operation, the spherical shut-off part of the flue gas non-return valve is lifted by the overpressure of the variable speed fan and thereby releases the flue gas (see page 49).

The flue gas non-return device closes the flue gas path for all boilers which are not in use.

Approval

The gas condensing boilers Vitodens 200-W, 19 to 105 kW, are tested and certified together with the flue gas system.

The flue gas system is CE-designated.

Inspection aperture

The FeuVo [Germany] requires the installation of an inspection aperture inside the installation room.

Use an inspection aperture in accordance with the selected flue pipe diameter (for the dimensions tables, see page 34).

5414 641 GB

Design and sizing information for connection on the flue gas side (cont.)

Components and pipe lengths

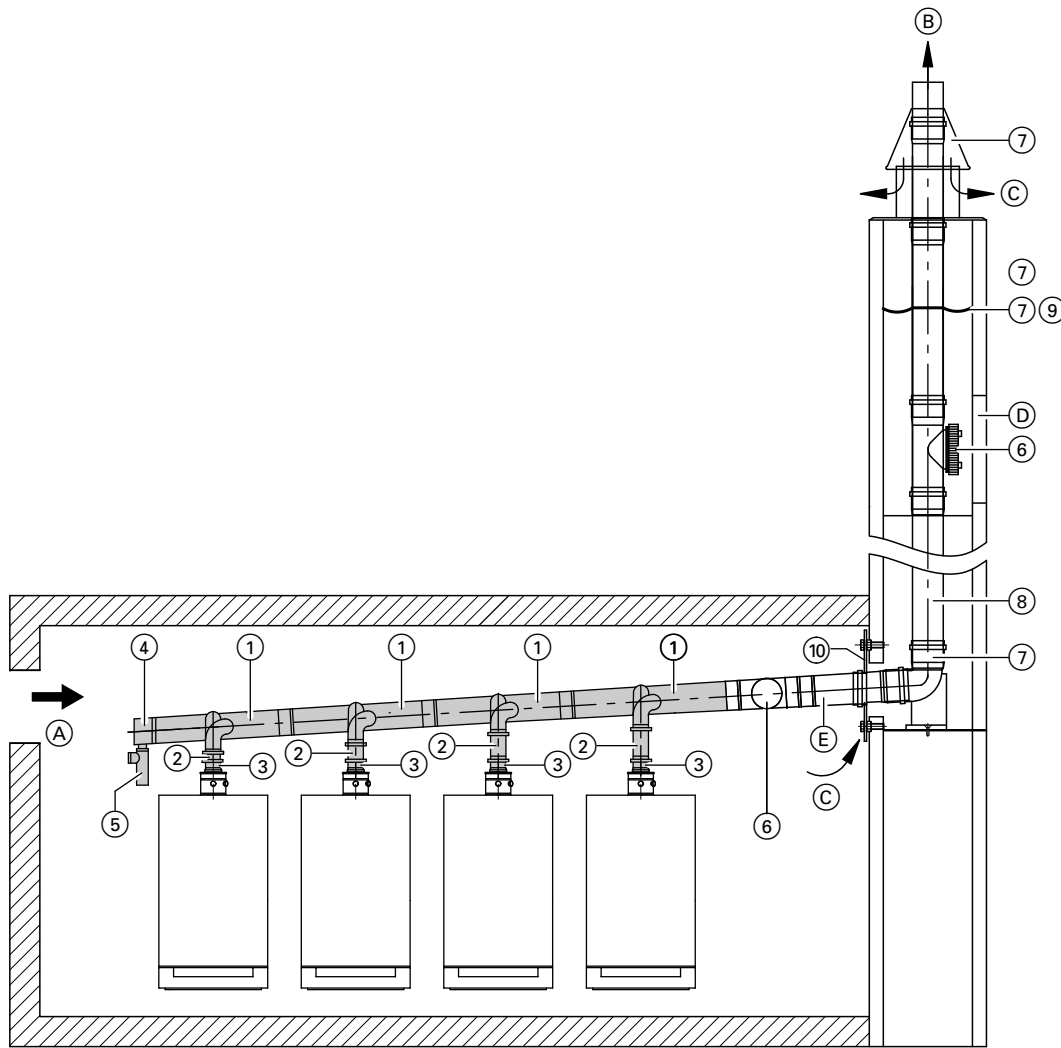

- (A) Ventilation air
- (B) Flue gas
- (C) Secondary ventilation

- (D) Inspection aperture
- (E) Connecting cable

Design and sizing information for connection on the flue gas side (cont.)

Standard delivery, flue gas cascade:

①	Flue gas header Ø 125, 150 or 200 mm
②	Flue gas non-return device Ø 80 or 100 mm (for each boiler)
③	Extension Ø 60 to Ø 80 mm (for Vitodens 200-W, 19 to 35 kW)
④	End piece with condensate drain
⑤	Siphon with hose
Further accessories (Ø 200 mm see Vitocrossal 300 pricelist):	
⑥	Inspection piece Ø 125, 150 or 200 mm
⑦	Standard duct set Ø 125, 150 or 200 mm comprising: – Support bend – Support rail – Duct cover – Spacers (3 pce, max. distance 5 m)
⑧	Flue pipe Ø 125, 150 or 200 mm 2 m long (2 pce = 4 m long) 2 m long (1 pce) 1 m long (1 pce) 0.5 m long (1 pce)
⑨	Spacers (3 pce, max. distance 5 m)
⑩	Ventilation bezel Ø 125, 150 or 200 mm

Positions 1 to 4 are part of the standard delivery of the flue gas cascade. The inspection piece and all other flue gas accessories should be ordered specifically for each system (Ø 200 mm see pricelist for flue gas system for Vitocrossal).

2

Max. total length of the flue pipe

Vitodens 200-W (19 to 35 kW) installed in series

Rated output	kW	2 x 19	3 x 19	4 x 19	2 x 26	3 x 26	4 x 26	2 x 35	3 x 35	4 x 35
Rated output (total)	kW	37	57	76	52	78	104	70	105	140
Max. total length of the flue pipe										
- System size 125 mm	m	25	25	—	25	—	—	—	—	—
- System size 150 mm	m	—	—	22	—	25	25	25	25	25

Vitodens 200-W (45 to 105 kW) installed in series

Rated output	kW	2 x 45	2 x 60	2 x 80	2 x 105	3 x 45	3 x 60	3 x 80	3 x 105	4 x 105
Rated output (total)	kW	90	120	160	210	135	180	240	315	420
Max. length of the total horizontal connecting pipe										
- System size 125 mm	m	3	3	—	—	4	—	—	—	—
- System size 150 mm	m	—	—	4	4	—	4	4	—	—
- System size 200 mm	m	—	—	—	—	—	—	—	5	4
Max. pipe length inside the duct										
- System size 125 mm	m	9	9	—	—	8	—	—	—	—
- System size 150 mm	m	—	—	16	16	—	18	16	—	—
- System size 200 mm	m	—	—	—	—	—	—	—	20	16
Max. total length of the flue pipe										
- System size 125 mm	m	12	12	—	—	12	—	—	—	—
- System size 150 mm	m	—	—	20	20	—	20	20	—	—
- System size 200 mm	m	—	—	—	—	—	—	—	25	20

Vitodens 200-W (45 to 105 kW) installed as a block

Rated output	kW	4 x 45	4 x 60	4 x 80	4 x 105
Rated output (total)	kW	180	240	320	420
Max. length of the total horizontal connecting pipe					
- System size 150 mm	m	5	5	—	—
- System size 200 mm	m	—	—	5	5
Max. pipe length inside the duct					
- System size 150 mm	m	10	10	—	—
- System size 200 mm	m	—	—	15	15
Max. total length of the flue pipe					
- System size 150 mm	m	15	15	—	—
- System size 200 mm	m	—	—	20	20

5414 641 GB

Design and sizing information for connection on the flue gas side (cont.)

Note

Flue gas parameters for the individual boilers can be transferred to the flue gas system calculation (see technical guide Vitodens).

The pressure drop of the flue gas non-return device has already been taken into account, and does not have to be drawn upon in the calculation.

The maximum operating pressure according to DVGW G 635 is not taken into account.

Installation and dimensions

Installation of the Vitodens with or without self-supporting mounting frame – in series (19 - 105 kW)

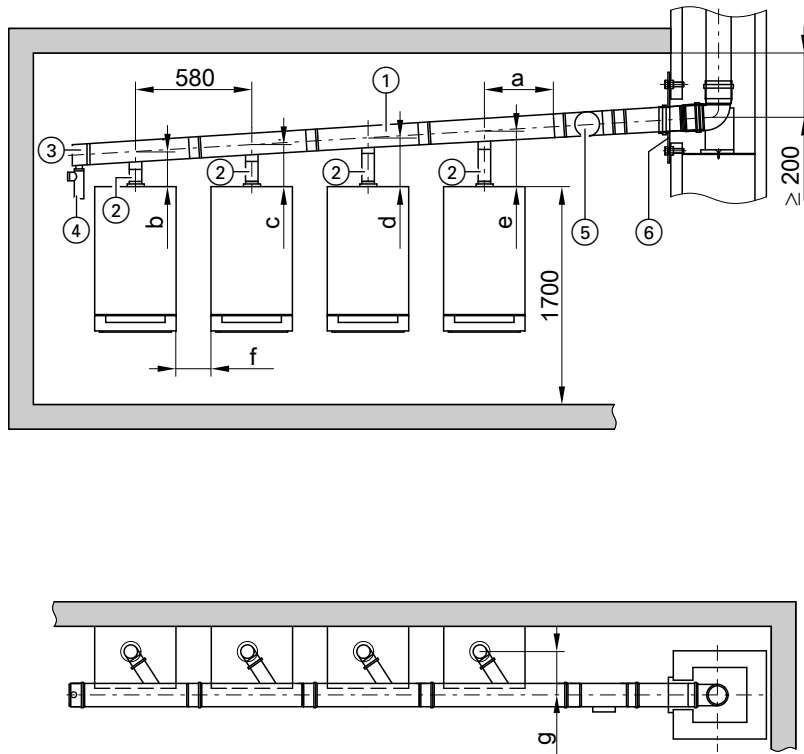

- | | |
|---|---|
| ① Flue gas header Ø 125, 150 or 200 mm | ④ Siphon with hose |
| ② Flue gas non-return device Ø 80 or 100 mm | ⑤ Inspection piece Ø 125, 150 or 200 mm |
| ③ End piece with condensate drain | ⑥ Ventilation bezel |

Header Ø mm	a mm	b mm	c mm	d mm	e mm	f mm	g mm
125							
– 19 - 35 kW	196	205	235	265	295	130	202
– 45 - 105 kW	196	146	176	207	237	100	202
150							
– 19 - 35 kW	261	205	235	265	295	130	233
– 45 - 105 kW	261	146	176	207	237	100	233
200							
– 105 kW	404	146	176	207	237	100	253

Install the flue gas header with a slope of at least 3°.

Trim the flue gas non-return devices in accordance with the markings on the plug-in end on the boiler side.

Design and sizing information for connection on the flue gas side (cont.)

Vitodens installation with a mounting frame – as a block (45 - 105 kW)

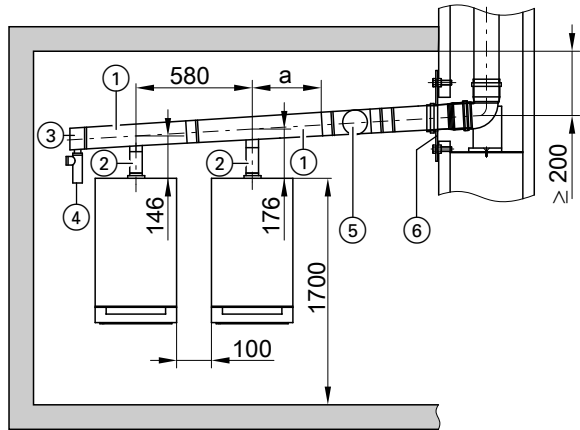

- ③ End piece with condensate drain
- ④ Siphon with hose
- ⑤ Inspection piece Ø 150 or 200 mm
- ⑥ Ventilation bezel

Header Ø mm	a mm	b mm
150	196	202
200	502	352

Install the flue gas header with a slope of at least 3°. Trim the flue gas non-return devices in accordance with the markings on the plug-in end on the boiler side.

2

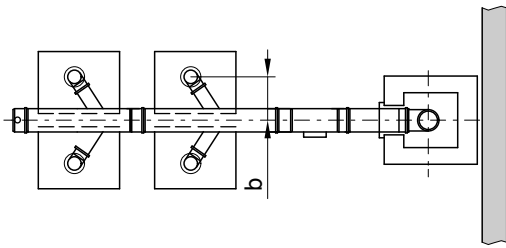

- ① Flue gas header Ø 150 or 200 mm
- ② Flue gas non-return device Ø 80 or 100 mm

Design and sizing information for connection on the flue gas side (cont.)

Multi-boiler systems with flue gas systems - negative pressure

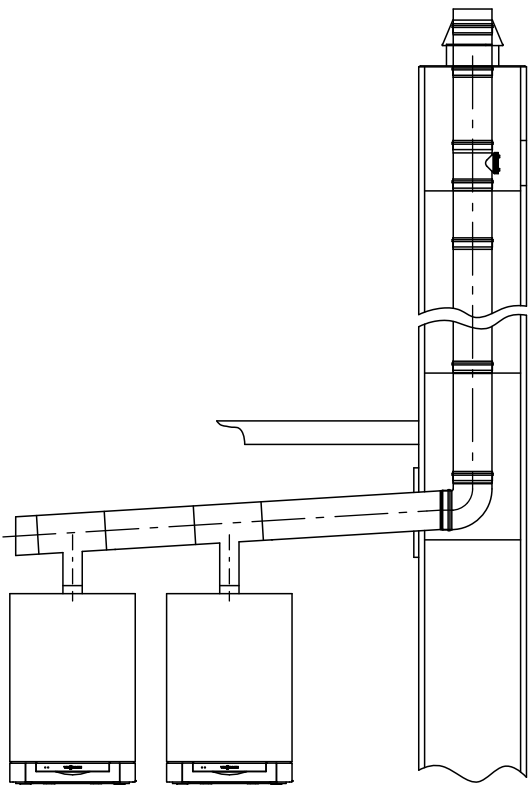

Size to EN 13384.

Flue gas header in the negative pressure range, see the Viessmann Vitoset pricelist.

Pressurised flue gas systems for multi-boiler systems, see page 32.

3

Flue gas system components

3.1 Balanced flue system components

Balanced flue pipe

(these pipes may be trimmed as required)

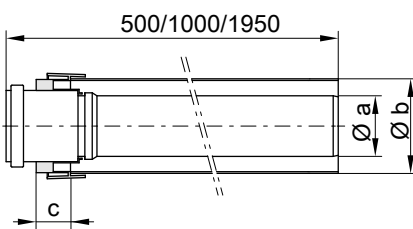

System size Ø 60 and 80 mm

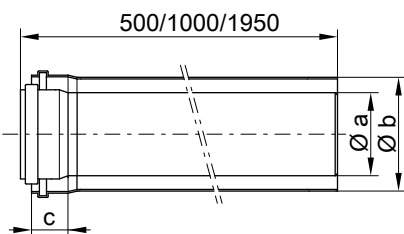

System size Ø 100 mm

System size Ø mm	Dimension [mm]		
	a	b	c
60	60	100	40
80	80	125	40
100	110	150	40

Balanced flue bend (87°)

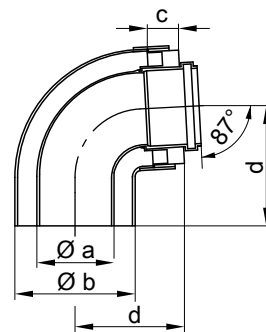

System size Ø 60 and 80 mm

Flue gas system components (cont.)

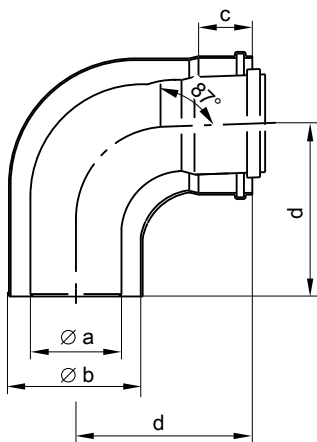

System size Ø 100 mm

System size Ø mm	Dimension [mm]			
	a	b	c	d
60	60	100	40	110
80	80	125	40	120
100	110	150	40	170

Balanced flue bend (45°)

Standard pack 2 pce

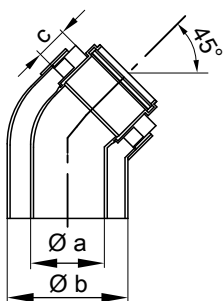

System size Ø 60 and 80 mm

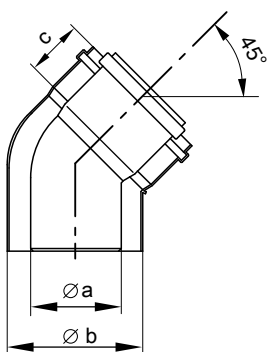

System size Ø 100 mm

System size Ø mm	Dimension [mm]		
	a	b	c
60	60	100	40
80	80	125	40
100	110	150	40

Balanced flue inspection piece (straight)

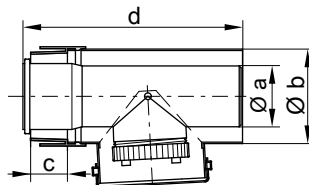

System size Ø 60 mm

System size Ø mm	Dimension [mm]			
	a	b	c	d
60	60	100	40	250

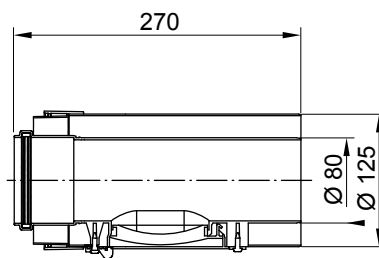

System size Ø 80 mm

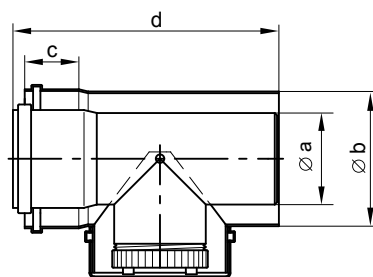

System size Ø 100 mm

System size Ø mm	Dimension [mm]			
	a	b	c	d
100	110	150	40	273

Balanced flue inspection bend (87°); system size Ø 60 and 80 mm

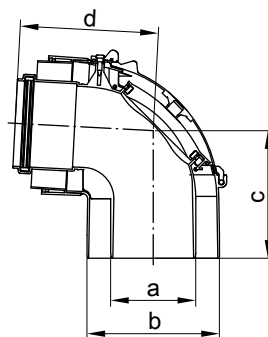

5414 641 GB

Flue gas system components (cont.)

System size Ø mm	Dimension [mm]			
	a	b	c	d
60	60	100	100	130
80	80	125	120	130

Balanced flue inspection tee (87°), system size Ø 100 mm

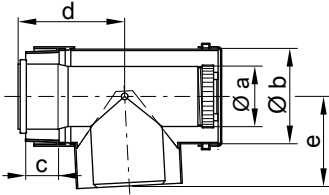

System size Ø mm	Dimension [mm]				
	a	b	c	d	e
100	110	150	40	120	140

Balanced flue adaptor

For system 80/125 to system 60/100

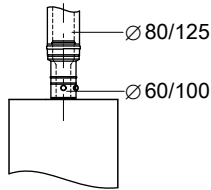

Balanced flue sliding coupling

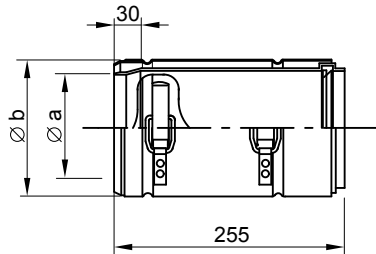

System size Ø mm	Dimension [mm]	
	a	b
60	60	100
80	80	125
100	110	150

Balanced flue wall bezel

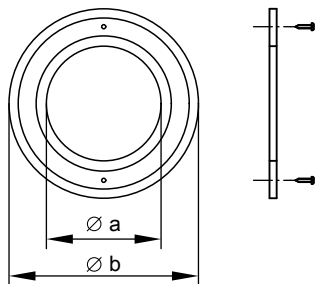

5414 641 GB

VITODENS

System size Ø mm	Dimension [mm]	
	a	b
60	102	194
80	130	230
100	155	230

Universal cover plate

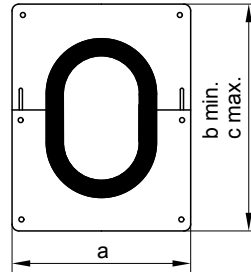

System size Ø mm	Dimension [mm]		
	a	b	c
60	250	246	310
80	250	246	310
80	280	286	350

Fixing clamp

For routing over internal or external walls, white.

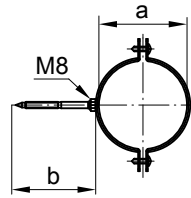

System size Ø mm	Dimension [mm]	
	a	b
60	100	100
80	125	100
100	150	100

Balanced flue roof outlet

with fixing clamp

Flue gas system components (cont.)

3

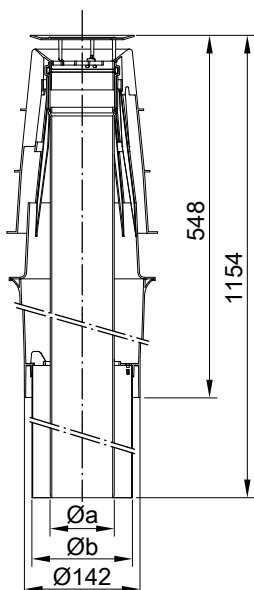

System size Ø 60 and 80 mm

System size Ø mm	Dimension [mm]	
	a	b
60	60	100
80	80	125

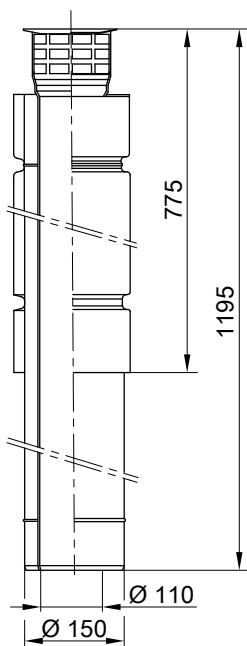

System size Ø 100 mm

Above-roof extension

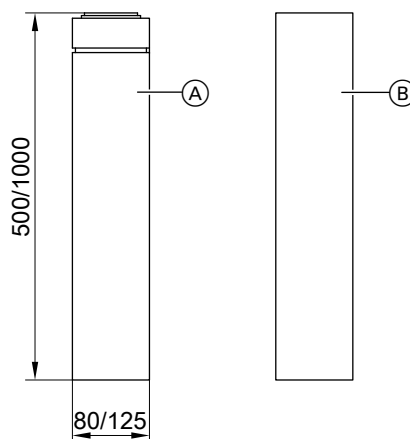

- (A) Above-roof extension
- (B) Casing pipe
- (C) Bracing clamp

Balanced flue external wall terminal (incl. wall bezels)

For system size Ø 60 mm and 80 mm

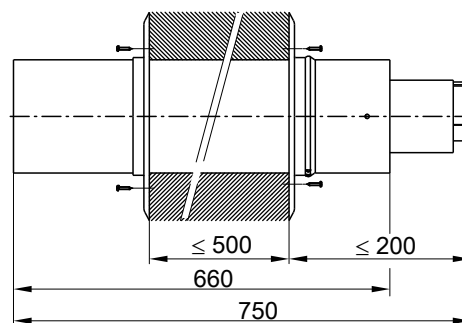

Step in the balanced flue pipe

Small offset A (2 × 45° balanced flue bend):

- 74 mm for system size Ø 60 mm (C = 174 mm)
- 93 mm for system size Ø 80 mm (C = 223 mm)
- 140 mm for system size Ø 100 mm (C = 328 mm):

Push two 45° balanced flue bends into each other and into the balanced flue.

Offset:

- In excess of 74 mm for system size Ø 60 mm
- In excess of 93 mm for system size Ø 80 mm
- In excess of 140 mm for system size Ø 100 mm:

Subject to the offset (dimension A) insert a balanced flue extension between both 45° bends (dimension B).

5414 641 GB

Flue gas system components (cont.)

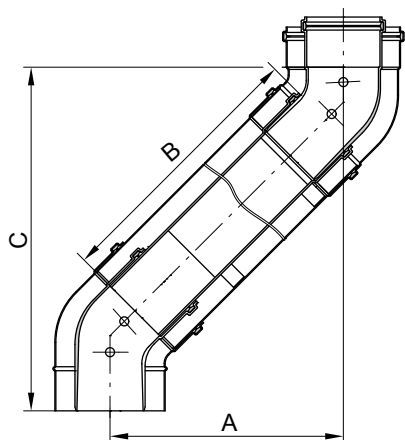

System size Ø 100 mm

Offset	A (mm)	200	250	300	350	390
Extension	B (mm)	134	205	275	346	403
Installed	C (mm)	390	438	488	538	578

Balanced flue room interconnection bezel

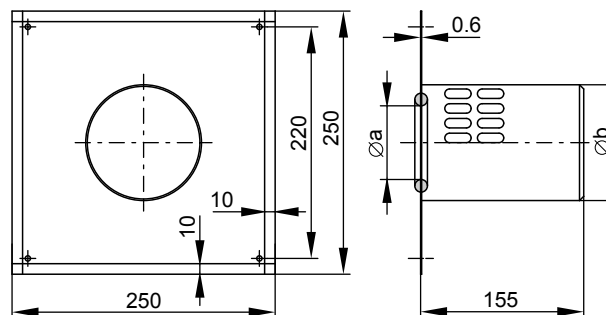

System size Ø 60 mm

Offset	A (mm)	150	200	250	300	350	390
Extension	B (mm)	153	224	295	372	436	487
Installed	C (mm)	250	300	350	400	450	490

System size Ø 80 mm

Offset	A (mm)	150	200	250	300	350	390
Extension	B (mm)	123	194	265	335	406	463
Installed	C (mm)	280	330	380	430	480	520

System size Ø mm	Dimension [mm]	
	a	b
60	60	100
80	80	125

3.2 Components for routing a flue over an external wall

External wall pack

External wall bend (A) with air inlet piece (B), twin fem. connection (C) and wall bezel (D)

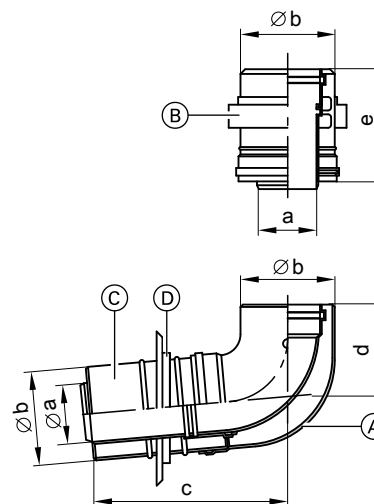
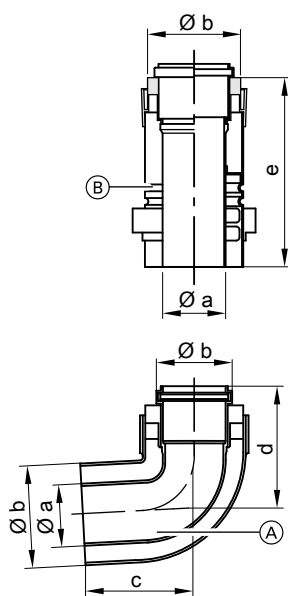

System size Ø 100 mm

System size Ø mm	Dimension [mm]				
	a	b	c	d	e
100	110	150	295	170	165

System size Ø mm	Dimension [mm]				
	a	b	c	d	e
60	60	100	110	110	250
80	80	125	120	120	250

5414 641 GB

Flue gas system components (cont.)

External wall pipe

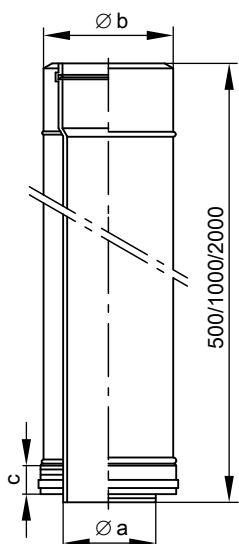

System size Ø mm	Dimension [mm]		
	a	b	c
60 ^{*2}	—	—	—
80 ^{*2}	—	—	—
100	110	150	40

External wall bend, 87°

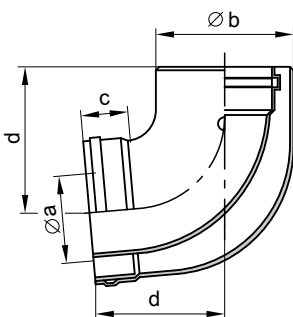

System size Ø mm	Dimension [mm]			
	a	b	c	d
60 ^{*2}	—	—	—	—
80 ^{*2}	—	—	—	—
100	110	150	40	170

External wall bend 45°

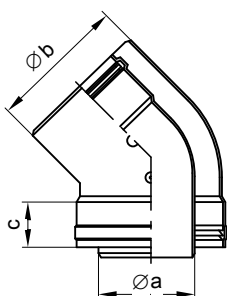

System size Ø mm	Dimension [mm]		
	a	b	c
60 ^{*2}	—	—	—
80 ^{*2}	—	—	—
100	110	150	40

External wall terminal

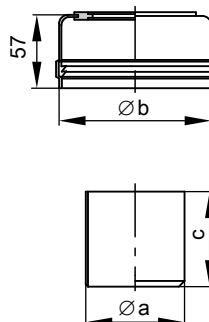

System size Ø mm	Dimension [mm]		
	a	b	c
60	60	100	110
80	80	125	110
100	110	152	85

External wall inspection piece

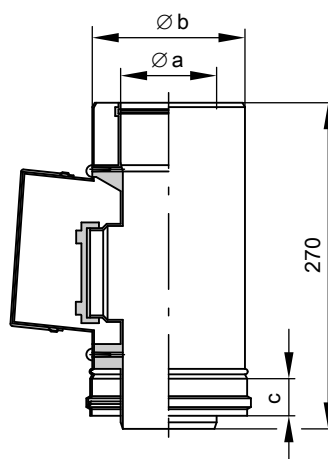

System size Ø mm	Dimension [mm]		
	a	b	c
60 ^{*2}	—	—	—
80 ^{*2}	—	—	—
100	110	150	40

^{*2} Use balanced flue components (see page 37).

Flue gas system components (cont.)

3.3 Single pipe system components

Flue pipe

(these pipes may be trimmed as required)

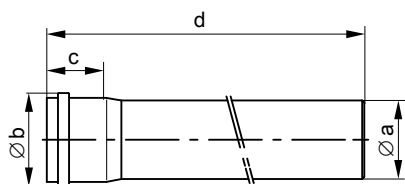

System size Ø mm	Dimension [mm]			d
	a	b	c	
60	60	73	58	500/1000/1950
80	80	94	57	500/1000/1950
100	110	128	72	500/1000/2000
125	125	145	75	500/1000/2000
150	160	184	83	500/1000/2000

Flue bend (87°)

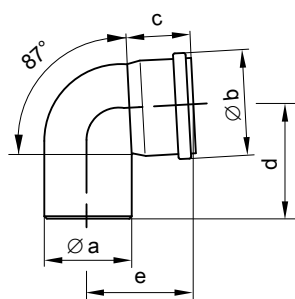

System size Ø mm	Dimension [mm]				
	a	b	c	d	e
60	60	73	55	110	120
80	80	94	60	120	130
100	110	128	72	130	130
125	125	145	75	150	150
150	160	184	83	170	170

Flue bend (45°)

Standard pack 2 pce

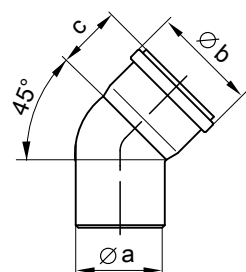

System size Ø mm	Dimension [mm]		
	a	b	c
60	60	73	55
80	80	94	60
100	110	128	72
125	125	145	75
150	160	184	83

Standard duct pack

Comprising support bends, support rail, duct cover and spacer

Support bend

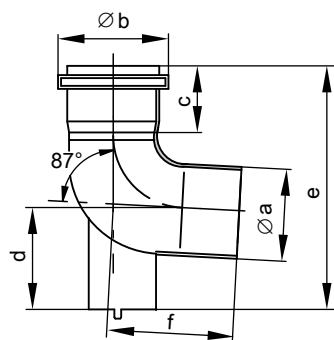

System size Ø mm	Dimension [mm]					
	a	b	c	d	e	f
60	60	73	55	60	180	110
80	80	94	60	80	210	120
100	110	128	72	112	245	120
125	125	145	75	120	264	147
150	160	184	83	137	296	163

Support rail

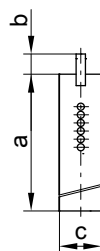

System size Ø mm	Dimension [mm]		
	a	b	c
60	350	50	50
80	350	50	50
100	350	50	50
125	400	50	50
150	400	50	50

Duct cover, PPs

(fixing material is part of the standard delivery)

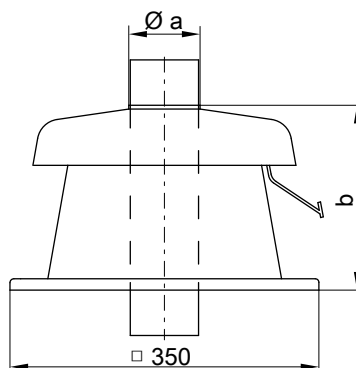

Flue gas system components (cont.)

System size Ø mm	Dimension [mm]	
	a	b
60	60	198
80	80	229
100	111	201

Metal duct cover

(fixing material is part of the standard delivery)

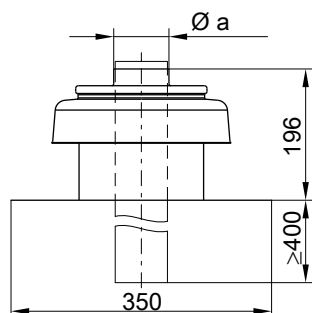

System size Ø mm	Dimension [mm]	
	a	b
80	80	110
100	110	110

Spacers

Standard pack 3 pce (applicable to internal duct dimensions 130 × 130 mm to 250 × 250 mm or Ø 150 mm to Ø 300 mm)

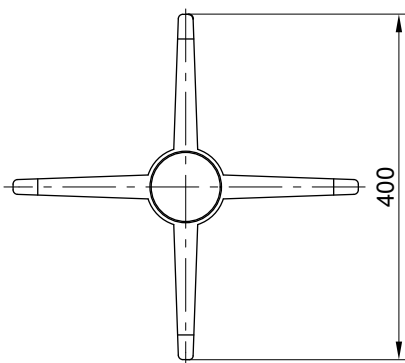

Extension

For system size Ø 60 mm to system size Ø 80 mm

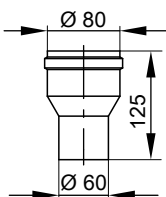

Inspection piece (straight)

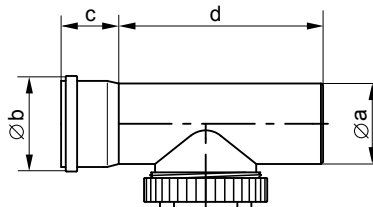

System size Ø mm	Dimension [mm]			
	a	b	c	d
60	60	73	55	195
80	80	94	60	210
100	110	128	72	201
125	125	145	75	205
150	160	184	83	225

Inspection tee

System size Ø 60 and 80 mm

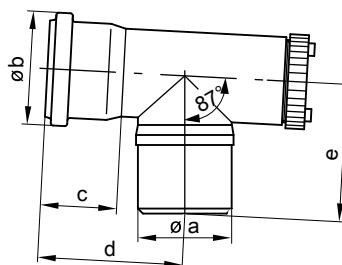

System size Ø mm	Dimension [mm]				
	a	b	c	d	e
60	60	73	55	130	100
80	80	94	60	142	130

Inspection bend

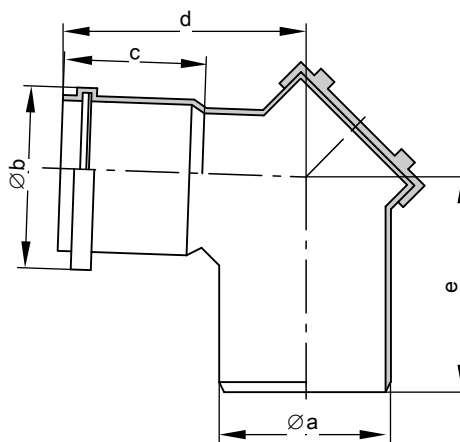

System size Ø mm	Dimension [mm]				
	a	b	c	d	e
100	110	128	72	143	142
125	125	145	75	148	148
150	160	184	83	159	163

Flue gas system components (cont.)

Ventilation bezel

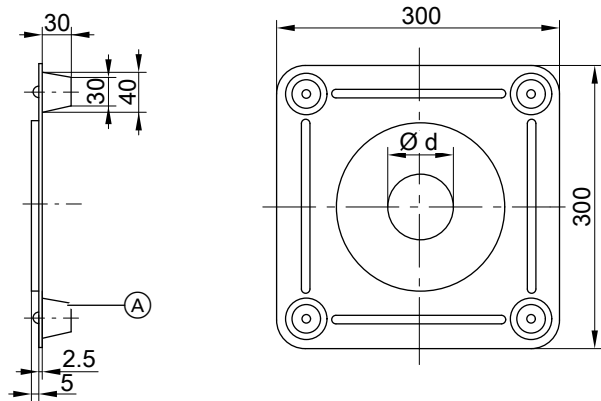

Ⓐ Spacers

System size Ø mm	Dimension [mm]	a
60		60
80		80
100		110

3.4 Components for multiple connections to a room sealed balanced flue – positive pressure for the Vitodens 200-W (4.8 to 26 kW)

Connection assembly for multiple connections

Connection tee with long fem. connection and fixing clamp

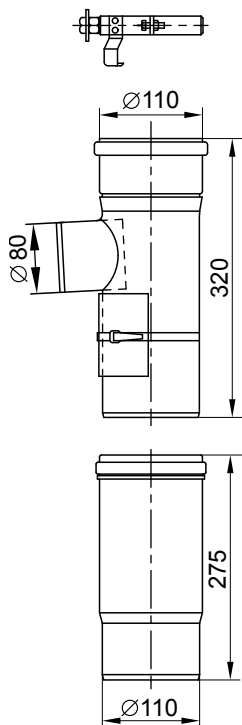

Connection assembly for condensate drain

Connection tee with long fem. connection and fixing clamp

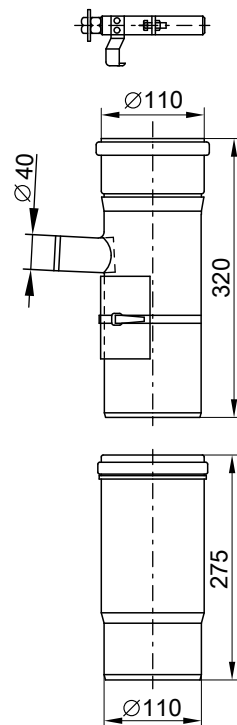

Flue gas system components (cont.)

Fixing clamp

For securing the flue pipe horizontally inside the duct.

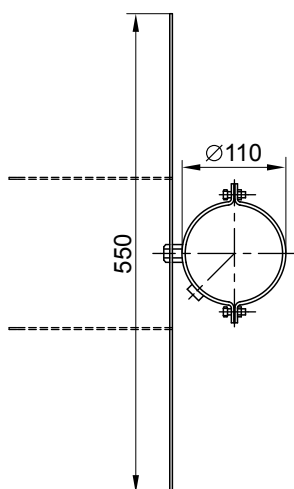

Flue gas non-return device

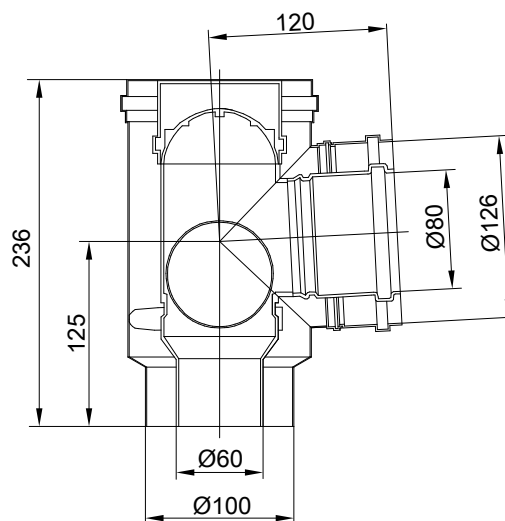

Connection for the condensate drain

Reducer from \varnothing 100 mm to \varnothing 40 mm

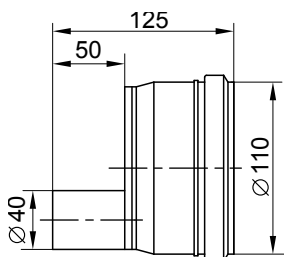

3.5 Components of the flexible single pipe system for a flexible flue

Flue pipe, flexible

Standard pack (length L) 8, 12.5 or 25 m on a roll

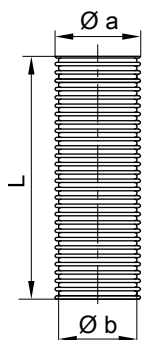

System size \varnothing 60 mm

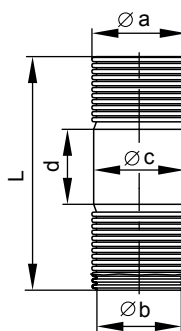

System size \varnothing 80 and 100 mm

System size \varnothing mm	Dimension [mm]			
	a	b	c	d
60	58	50	-	-
80	84	74	80	62
100	110	110	110	95

Flue gas system components (cont.)

Pipe lowering attachment with 20 m rope

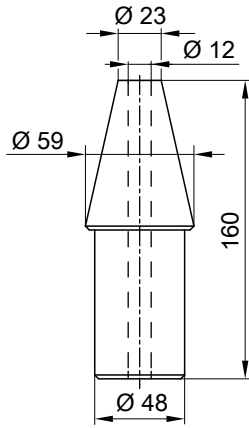

System size \varnothing 60 mm

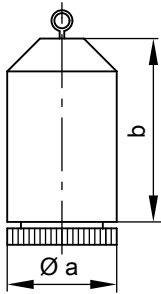

System size \varnothing 80 and 100 mm

System size \varnothing mm	Dimension [mm]	
	a	b
80	100	150
100	125	160

Inspection piece (straight)

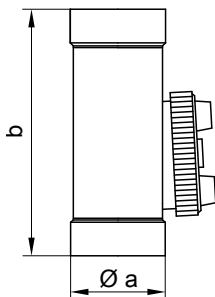

System size \varnothing 60 mm

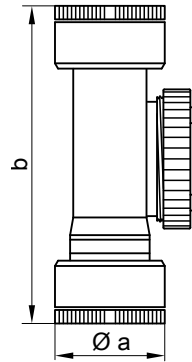

System size \varnothing 80 and 100 mm

System size \varnothing mm	Dimension [mm]	
	a	b
60	63	235
80	100	266
100	125	330

Connecting piece

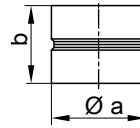

System size \varnothing 60 mm

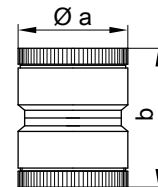

System size \varnothing 80 and 100 mm

System size \varnothing mm	Dimension [mm]	
	a	b
60	63	52
80	100	110
100	125	160

Duct cover with terminal

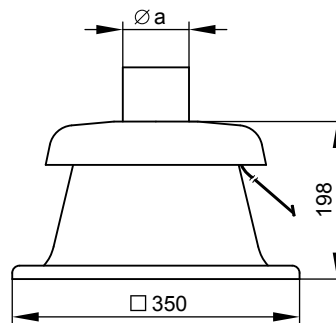

Flue gas system components (cont.)

System size Ø mm	Dimension [mm]	a
80		80
100		110

Spacers

Standard pack 5 pce

Applicable to internal duct dimensions 130 × 130 mm to 250 × 250 mm or Ø 150 mm to Ø 300 mm.

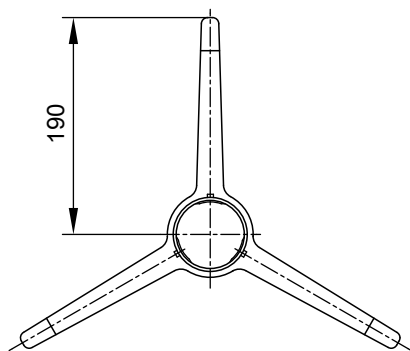

System size Ø 60 mm

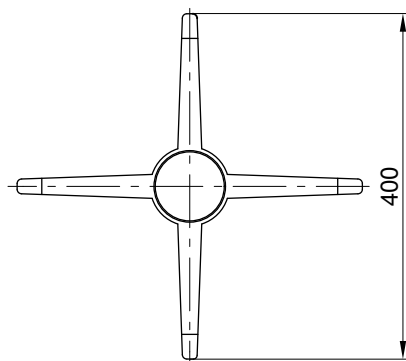

System size Ø 80 and 100 mm

3

3.6 Components for multi-boiler systems

Flue gas header

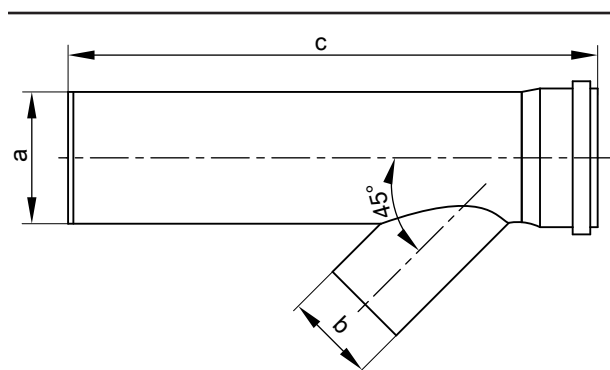

Installation in series

System size Ø mm	Dimension [mm]		
	a	b	c
125	125	80	650
150	160	110	650
200	200	110	680

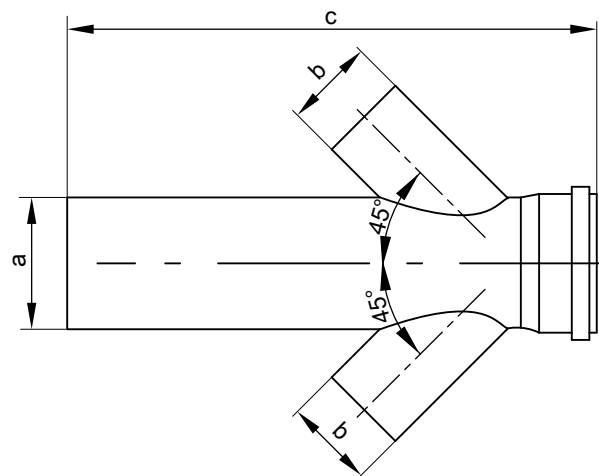

Installation as a block

System size Ø mm	Dimension [mm]		
	a	b	c
150	160	80	650
200	200	110	680

Flue gas system components (cont.)

End piece with condensate drain

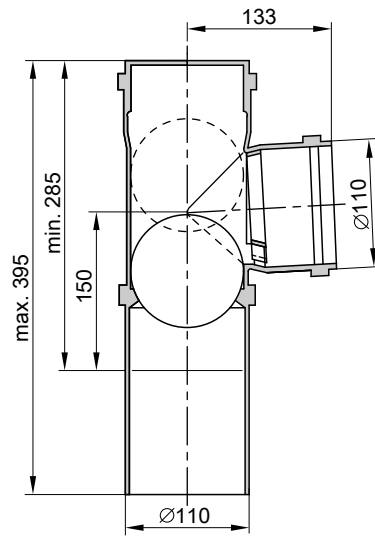
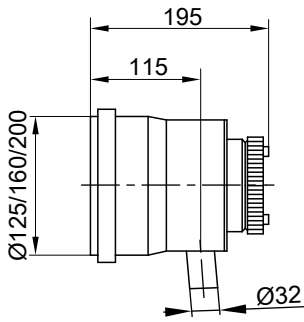

Siphon with drain hose

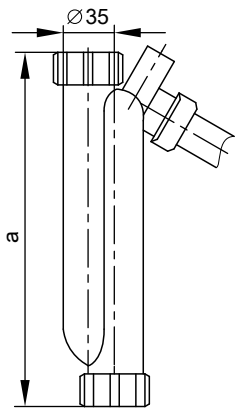

System size Ø 100 mm

Rated output kW	Dimension [mm]
19 – 60	a
80 – 105	248
	300

Flue gas non-return device

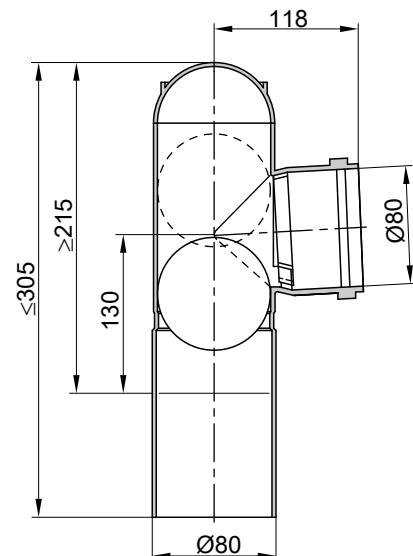

5414 641 GB System size Ø 80 mm

3.7 Roof elements

Universal roof tile

(suitable for roof slopes of 25 to 45°)

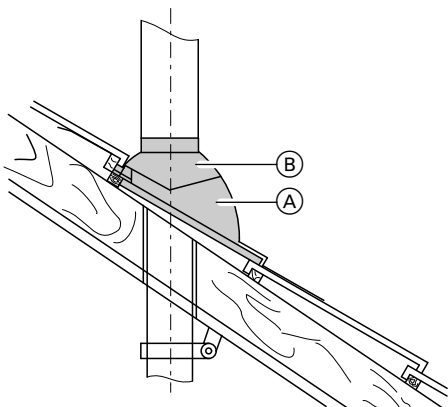

- (A) Universal roof tile
- (B) Pipe outlet for universal roof tile

Pipe outlet for Klöber roof tiles

(suitable for roof slopes from 20 to 50°)

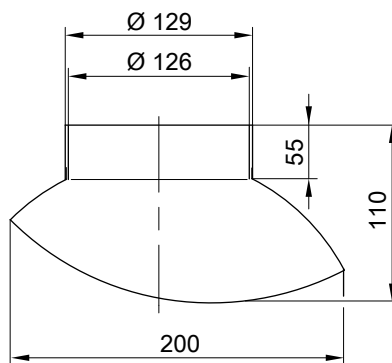

- (C) Ventilation membrane
- (D) Thermal insulation
- (E) Insulation
- (F) Ceiling
- (G) Vertical coaxial roof outlet

Flat roof collar

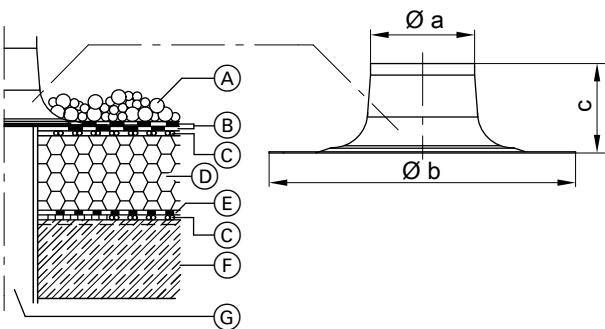

- (A) Gravel ballast
- (B) Insulation membrane

System size Ø mm	Dimension [mm]		
	a	b	c
60	135	390	250
80	135	390	250
100	170	470	250

Keyword index

A		I	
Accessories		Installation options.....	7
■ for the flue gas system.....	10	M	
B		Moisture-resistant chimney.....	31
Balanced flue operation.....	4, 10	Multiple flue (chimney).....	25
Balanced flue system.....	10	O	
Building Regulations approval [Germany].....	6	Open flue operation.....	5, 30
C		R	
Cascade flue gas system.....	32	Roof outlet, vertical.....	16
Certificate.....	6	Room sealed balanced flue.....	25
Connection on the flue gas side.....	4	Routing over an external wall.....	4
D		V	
Duct dimensions.....	11, 27	Vertical roof outlet.....	16
E			
External wall outlet.....	18		
F			
Flue gas header.....	10		
Flue gas high limit safety cut-out.....	5		
Flue gas systems			
■ for balanced flue operation.....	4		
■ for open flue operation.....	5		

Printed on environmentally friendly,
chlorine-free bleached paper



Subject to technical modifications.

Viessmann Werke GmbH&Co KG
D-35107 Allendorf
Telephone: +49 6452 70-0
Fax: +49 6452 70-2780
www.viessmann.com

Viessmann Limited
Hortonwood 30, Telford
Shropshire, TF1 7YP, GB
Telephone: +44 1952 675000
Fax: +44 1952 675040
E-mail: info-uk@viessmann.com

5414 641 GB