

Service instructions  
for contractors



Vitosol-F

*For applicability, see the last page*



## VITOSOL-F

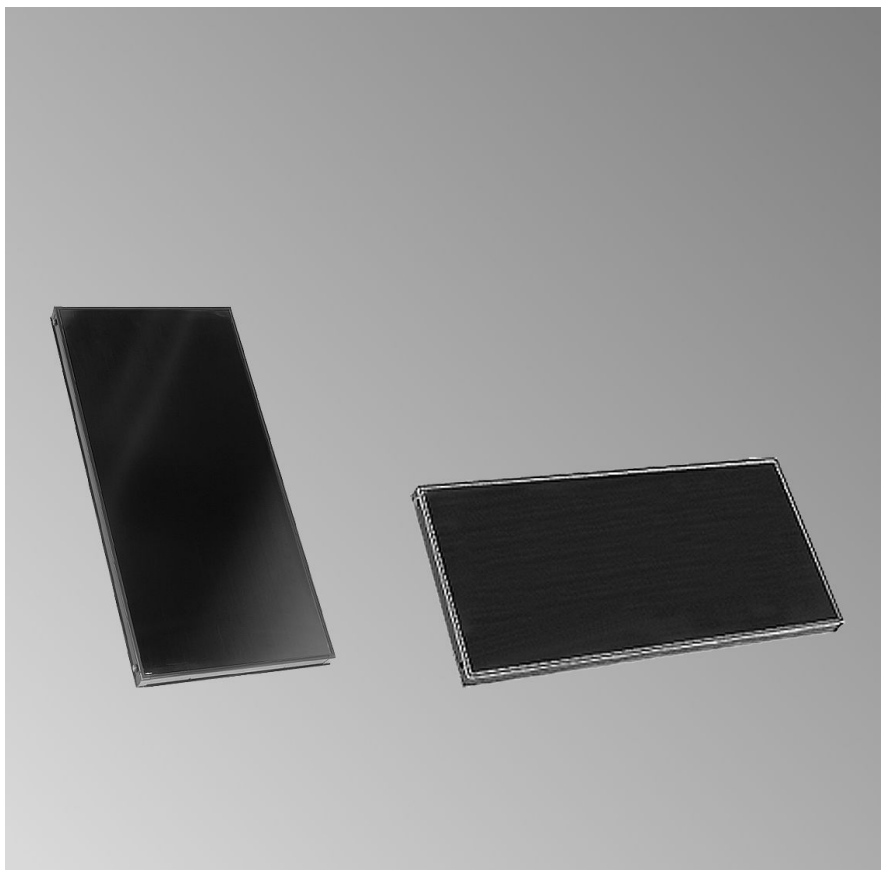

## Safety instructions



Please follow these safety instructions closely to prevent accidents and material losses.

### Safety instructions explained



#### **Please note**

This symbol warns against the risk of material losses and environmental pollution.

#### **Note**

*Details identified by the word "Note" contain additional information.*

### Target group

These instructions are exclusively designed for qualified personnel.

- Work on electrical equipment must only be carried out by a qualified electrician.
- The system must be commissioned by the system installer or a qualified person authorised by the installer.

### Regulations

Observe the following when working on this system

- all legal instructions regarding the prevention of accidents,
- all legal instructions regarding environmental protection,
- the Code of Practice of relevant trade associations.
- all current safety regulations as defined by DIN, EN, DVGW, VDE and all locally applicable standards

### Working on the system

- Isolate the system from the power supply and check that it is no longer 'live', e.g. by removing a separate fuse or by means of a main isolator.
- Safeguard the system against unauthorised reconnection.



#### **Please note**

Electronic modules can be damaged by electrostatic discharges.

Touch earthed objects, such as heating or water pipes, to discharge static loads.

### Repair work



#### **Please note**

Repairing components that fulfil a safety function can compromise the safe operation of your heating system.

Replace faulty components only with original Viessmann spare parts.

## **Safety instructions** (cont.)

### **Ancillary components, spare and wearing parts**



#### **Please note**

Spare and wearing parts that have not been tested together with the heating system can compromise its function. Installing non-authorised components and non-approved modifications or conversions can compromise safety and may invalidate our warranty.

For replacements, use only original spare parts supplied or approved by Viessmann.

## Index

### **Commissioning, inspection, maintenance**

Steps - commissioning, inspection and maintenance.....	5
Further details regarding the individual steps.....	6

### **Parts lists**

Parts list Vitosol 200-F, 300-F.....	11
--------------------------------------	----

### **Specification**

Vitosol 200-F.....	13
Vitosol 300-F.....	13
Solar-Divicon (accessory).....	13
Heat transfer medium (accessory).....	13

### **Certificates**

Declaration of conformity.....	15
--------------------------------	----

## Steps - commissioning, inspection and maintenance

For further information regarding the individual steps, see the page indicated

Commissioning steps	Inspection steps	Maintenance steps	Page
•			<b>1. Flushing, testing for leaks and filling the solar thermal system.....</b> 6
•	•	•	<b>2. Checking the function of the safety equipment</b>
•	•	•	<b>3. Checking the expansion vessel and the system pressure.....</b> 7
•	•	•	<b>4. Checking the electrical connections.....</b> 7
•		•	<b>5. Starting the system.....</b> 7
•		•	<b>6. Venting the solar thermal system.....</b> 8
•	•	•	<b>7. Checking the switching function of the solar control unit.....</b> 9
•	•	•	<b>8. Checking the flow rate</b>
		•	<b>9. Shutting down the system.....</b> 9
	•	•	<b>10. Checking gaskets and seals</b>
	•	•	<b>11. Checking the frost protection temperature and the pH value of the heat transfer medium.....</b> 10
	•	•	<b>12. Checking the thermal insulation of the pipes.....</b> 10
	•	•	<b>13. Checking circulation pumps</b>
		•	<b>14. Cleaning collectors</b>

## Further details regarding the individual steps

### Flushing, testing for leaks and filling the solar thermal system

- **Never** drain the system with a vacuum pump.
  - Check the system for leaks:  
The collector in its cold state must be subject to a positive pressure of at least 1.0 bar. At a static head of 10 m, this would result in a system pressure of 2.0 bar.
1. Leave collectors covered or cover if necessary.  
Open any installed shut-off gates or valves by hand. Open the non-return valves when using a Solar-Divicon: Flow/return: Turn the thermometer clockwise through 45°.
  2. Close the shut-off valve of the fill valve and open the drain valve.
  3. Flush the system via the return connections. Fill and flush the system with heat transfer medium via the fill valve.  
Flush using a high speed pump over an open container and continue until no air remains in the collector system. Correct commissioning can only be guaranteed with a system that is completely free of air. Now close the drain valves on the fill valve, open the shut-off valve and check the system for leaks. Observe the permissible operating pressure.  
Pressure must not drop for at least 30 minutes.

#### Notes

- A heat transfer medium containing glycol can deteriorate if it is exposed to temperatures above 170 °C for prolonged periods (stagnation). Temperatures in excess of 200 °C result in a slow thermal breakdown of the 1,2-propylene glycol that can be recognised by a darkening of the heat transfer medium.  
Furthermore, it can result in the solar circuit suffering from sludge and hard deposits, particularly in conjunction with other contaminants (cinder, swarf) and air.
- Ensure that the system is correctly flushed, filled and ventilated after installation.
- After filling the system with the heat transfer medium, ensure that the system is fully vented and that heat is transferred inside the system.
- Blow-off and drain lines must terminate in an open container, that is capable of collecting the full collector content.

## Further details regarding the individual steps (cont.)

### Checking the expansion vessel and the system pressure

1. Drain the system. For this, close the cap valve on the expansion vessel (if installed) and reduce the pressure.
2. If the pre-charge pressure of the expansion vessel is lower than the set value, top up with nitrogen until the pre-charge pressure equals the set value.  
Static head (top edge of collector to expansion vessel): ..... m  
Set pre-charge pressure of the expansion vessel:  
 $0.7 \text{ bar} + 0.1 \times \text{static head in m}$   
 $0.7 \text{ bar} + 0.1 \times \text{..... m} = \text{..... bar}$
3. Top-up heat transfer medium until the system pressure is 0.3 to 0.5 bar higher than the set pre-charge pressure of the expansion vessel (create a safety water seal in the expansion vessel).  
The **safety water seal** should be  $0.005 \times$  liquid content of the complete system, but no less than **3 litres**.  
Liquid content of the system = content of pipes + content of collectors + content of the indirect coil of the DHW cylinder and safety water seal for the expansion vessel.

### Checking the electrical connections

Check the tightness of the electrical plug-in connectors and cable grommets; check cables for damage.

### Starting the system

Observe operating instructions of installed components.

## Further details regarding the individual steps (cont.)

### Venting the solar thermal system

1. Open the air vent valve.  
Vent the circulation pumps. For this, adjust the circulation pumps to their maximum speed, switching the pump ON and OFF several times (a ventilated pump runs almost silently) through a relay test (manual operation).  
Repeat the ventilation process **until the float in the flow meter** of the Solar-Divicon holds a constant position when the pump is running (highest pump rate).
2. Set the required flow rate via the pump rate of the circulation pump (see following tables for approximate set values).  
Check the value underneath the float.
3. Repeat the venting process after the system has been operational for several days.
4. Always shut off the air vent valve after venting.

**Note**

*If the system pressure drops, top-up the heat transfer medium in the cold state and vent again.*

**Note**

*Air can be recognised in the flow rate indicator (float moves).*

### Adjustable flow rates

#### Vitosol 200-F, type 5DI

Throughput 3 to 4 l/min

#### Vitosol 200-F, 300-F

The details in the following tables do not take the pipe pressure drop into account.

### Further details regarding the individual steps (cont.)

High-flow operation, 40 l/(h·m <sup>2</sup> )		Low-flow operation, 15 l/(h·m <sup>2</sup> )	
Number of collectors	Flow rate in l/min	Number of collectors	Flow rate in l/min
2	3	6	3.5
3	4.5	7	4
4	6	8	4.5
5	7.5	9	5
6	9.5	10	5.5
7	10.5	11	6.5
8	12.5	12	7
9	14	13	7.5
10	15.5	14	8
11	17	15	8.5
12	18.5	16	9
13	20	18	10.5
14	21.5	20	11.5
15	23.5		

### Checking the switching function of the solar control unit



Solar control unit installation and service instructions

### Shutting down the system



#### Please note

To prevent equipment damage, cover the collectors before commencing any work on the components of the solar thermal system.

Mixing the heat transfer medium with water reduces the frost and corrosion protection. Only flush the system with the specified heat transfer medium. **Never** mix "Tyfocor LS" with other heat transfer media.

Electrically isolate the system (e.g. at a separate MCB/fuse or the main isolator) and safeguard against unauthorised reconnection.

## Further details regarding the individual steps (cont.)

### Checking the frost protection temperature and the pH value of the heat transfer medium

Check the frost protection temperature of the "Tyfocor LS" heat transfer medium with a Viessmann antifreeze tester or the manual refractometer in the solar service case (accessory).

Check the pH value using the pH strip in the solar service case (accessory).



Solar service case operating instructions

### Checking the thermal insulation of the pipes

Check the thermal insulation of the pipes for positioning and damage and adjust if required.

Replace any damaged parts.

#### **Note**

*The thermal insulation of external pipes must be resistant to temperature and UV rays. The insulation must be protected against attack from small animals and birds (e.g. metal sheath).*

## Parts list Vitosol 200-F, 300-F

### **When ordering spare parts:**

*Quote the part and serial no. (see type plate) and the position no. of the required part (as per this parts list).*

*Obtain standard parts from your local supplier.*

### **Parts**

- |   |  |
|---|--|
| 001 Connection pipe                           | 014 Profile clip   |
| 002 Connection pipe (short)                   | 015 Diagonal sealing strip   |
| 003 Connection pipe (long)                    | 016 Support sleeve   |
| 004 Plug                                      | 017 Resilient buffer   |
| 005 Locking ring fitting with support sleeves | 018 Mounting bracket   |
| 006 Elbow fitting with support sleeves        | Parts not shown  |
| 007 Clamping bracket, complete                | 020 Special grease   |
| 008 Connecting part                           | 021 Dismantling instructions   |
| 009 Mounting bracket                          | 022 Operating instructions   |
| 010 Spacer plug                               | 023 Service instructions   |
| 011 Retaining bracket                         | 025 Installation instructions for sloping roofs (pitched roofs), above roof installation with roof hooks     |
| 012 O-ring                                    | 026 Installation instructions for sloping roofs (pitched roofs), roof integration                            |
| 013 Retaining screws                          | 027 Installation instructions for flat roofs or freestanding installation                                    |
|   | 028 Installation instructions for sloping roofs (pitched roofs), above roof installation with rafter anchors |

Parts lists

**Parts list Vitosol 200-F, 300-F (cont.)**

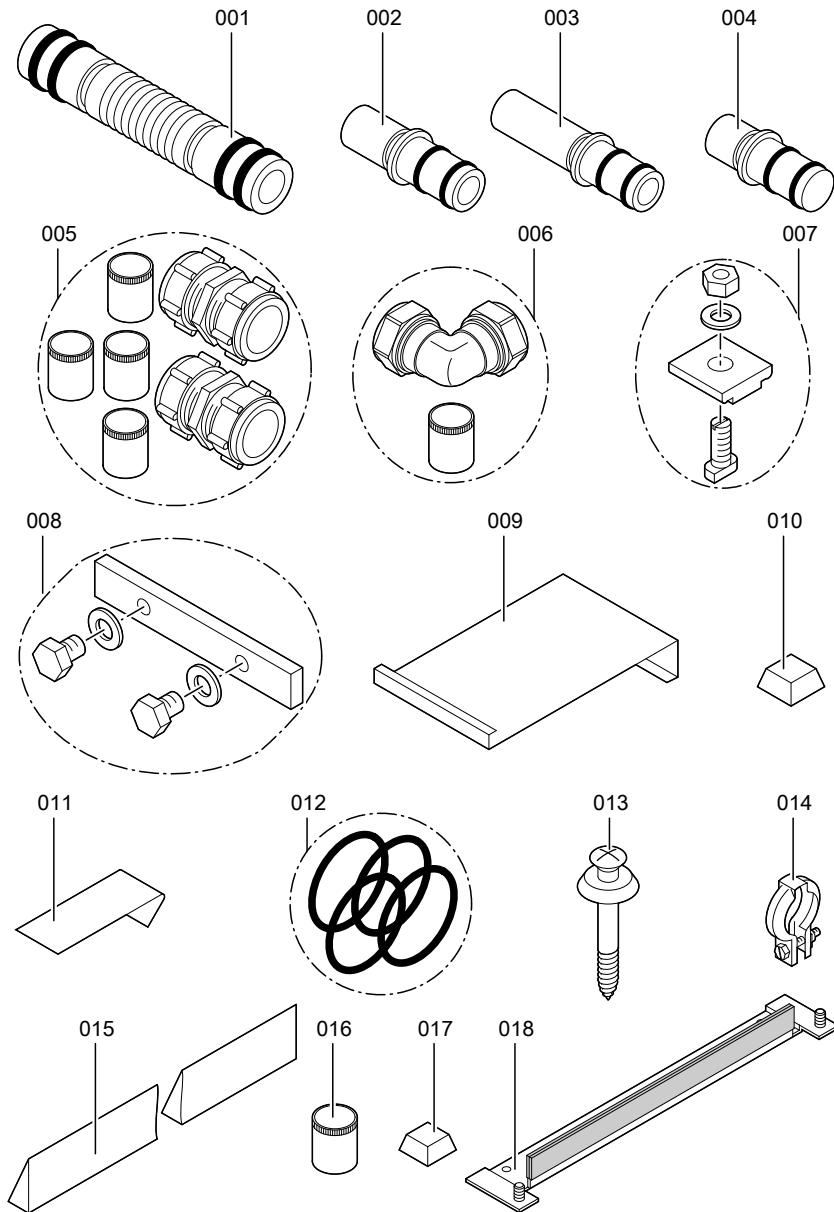

### Vitosol 200-F

Type		SV/SH	5DI
Absorber area	m <sup>2</sup>	2.31	4.76
Aperture area	m <sup>2</sup>	2.33	4.96
Thermal capacity c	kJ/(m <sup>2</sup> ·K)	5.35	6.40
Max. idle temperature	°C	202	185
Permiss. operating pressure	bar	6	6
Content, heat transfer medium	litres	1.83/2.48	4.2

### Vitosol 300-F

Type		SV/SH	
Absorber area	m <sup>2</sup>		2.32
Aperture area	m <sup>2</sup>		2.33
Thermal capacity c	kJ/(m <sup>2</sup> ·K)		5.35
Max. idle temperature	°C		212
Permiss. operating pressure	bar		6
Content, heat transfer medium	litres		1.83/2.48

### Solar-Divicon (accessory)

Safety valve	6 bar, 120 °C
Max. operating temperature	120°C
Permiss. operating pressure	6 bar

### Heat transfer medium (accessory)

The heat transfer medium provided is a liquid based on 1,2-propylene glycol with frost protection down to -28 °C. Monitor the operating condition of the medium as part of the annual service of the solar thermal system by the heating contractor.

The solar service case (accessory) enables, amongst others, the checking of the pH value and the frost protection temperature.

In some cases the manufacturer of the heat transfer medium can carry out a laboratory test of the medium, subject to arrangement.

Specification

## **Heat transfer medium (accessory)** (cont.)

TYFOROP CHEMIE GmbH  
Anton-Rée-Weg 7  
D - 20537 Hamburg  
e-mail: [info@tyfo.de](mailto:info@tyfo.de)  
Internet: [www.tyfo.de](http://www.tyfo.de)

## Declaration of conformity

We, Viessmann Werke GmbH & Co KG, D-35107 Allendorf, declare as sole responsible body, that the products

**Vitosol 200-F and 300-F**

conform to the following standards:

DIN 1055

EN 12975 to solar KEYMARK

In accordance with the following directives, these products are designated C€:

2006/95/EC

89/336/EEC

97/23/EC

**Details according to the Pressure Equipment Directive (97/23/EC):**

- Heated pressure equipment
  - Class I according to appendix II, diagram 5
  - Module A according to appendix III
  - Identification of individual devices with a content of less than 2 litres as assembly according to article 3 (2), subject to the installation of at least one pair
- The pressure device was tested without fitted equipment (safety assembly).  
The pressure device must be equipped in accordance with current national regulations prior to installation and commissioning.

The **product characteristics determined as system values for the Vitosol product as part of EC type testing according to the Efficiency Directive** (see specification table) can be used for the energy assessment of heating and ventilation equipment to DIN V 4701-10.

Allendorf, 1. March 2009

Viessmann Werke GmbH&Co KG



pp. Manfred Sommer

## Applicability

Applicable to the following collectors:

Vitosol 200-F, type 5DI	part no. 3004 363
Vitosol 200-F, type SV2	part no. 7248 237
Vitosol 200-F, type SH2	part no. 7248 238
Vitosol 200-F, type SV2A	part no. 7374 162
Vitosol 200-F, type SH2A	part no. 7374 161
Vitosol 200-F, type SV2B	part no. 7417 763
Vitosol 200-F, type SH2B	part no. 7417 764
Vitosol 300-F, type SV3	part no. 7248 611
Vitosol 300-F, type SH3	part no. 7248 612
Vitosol 300-F, type SV3A	part no. 7374 164
Vitosol 300-F, type SH3A	part no. 7374 163
Vitosol 300-F, type SV3B	part no. 7417 765
Vitosol 300-F, type SH3B	part no. 7417 766

Viessmann Werke GmbH&Co KG  
D-35107 Allendorf  
Telephone: +49 6452 70-0  
Fax: +49 6452 70-2780  
[www.viessmann.com](http://www.viessmann.com)

Viessmann Limited  
Hortonwood 30, Telford  
Shropshire, TF1 7YP, GB  
Telephone: +44 1952 675000  
Fax: +44 1952 675040  
E-mail: [info-uk@viessmann.com](mailto:info-uk@viessmann.com)

5692 808 GB Subject to technical modifications.

Printed on environmentally friendly,  
chlorine-free bleached paper

