

Installation and service instructions for contractors

VIESMANN

Vitodens 200-W

Type B2HF, B2KF, 1.9 to 32 kW

Wall mounted gas condensing boiler with 7 inch colour touchscreen

Natural gas and LPG version



VITODENS 200-W



Safety instructions

-  Please follow these safety instructions closely to prevent accidents and material losses.

Safety instructions explained

-  **Danger**
This symbol warns against the risk of injury.

-  **Please note**
This symbol warns against the risk of material losses and environmental pollution.

Note
Details identified by the word "Note" contain additional information.

Target group

These instructions are exclusively intended for qualified contractors.

- Work on gas installations may only be carried out by a registered gas fitter.
- Work on electrical equipment may only be carried out by a qualified electrician.
- The system must be commissioned by the system installer or a qualified person authorised by the installer.

Regulations to be observed

- National installation regulations
- Statutory regulations for the prevention of accidents
- Statutory regulations for environmental protection
- Codes of practice of the relevant trade associations
- Relevant country-specific safety regulations

Safety instructions for working on the system

Working on the system

- Where gas is used as the fuel, close the main gas shut-off valve and safeguard it against unintentional reopening.
- Isolate the system from the power supply, e.g. by removing the separate fuse or by means of a mains isolator, and check that it is no longer live.
- Safeguard the system against reconnection.
- Wear suitable personal protective equipment when carrying out any work.

Safety instructions (cont.)**Danger**

Hot surfaces and fluids can lead to burns or scalding.

- Before maintenance and service work, switch OFF the appliance and let it cool down.
- Never touch hot surfaces on the boiler, burner, flue system or pipe-work.

**Please note**

Electronic assemblies can be damaged by electrostatic discharge. Prior to commencing work, touch earthed objects such as heating or water pipes to discharge static loads.

Repair work**Please note**

Repairing components that fulfil a safety function can compromise the safe operation of the system. Replace faulty components only with genuine Viessmann spare parts.

Auxiliary components, spare and wearing parts**Please note**

Spare and wearing parts that have not been tested together with the system can compromise its function. Installing non-authorised components and making non-approved modifications or conversions can compromise safety and may invalidate our warranty. For replacements, use only original spare parts supplied or approved by Viessmann.

Safety instructions for operating the system

If you smell gas

-  **Danger**
Escaping gas can lead to explosions which may result in serious injury.
- Do not smoke. Prevent naked flames and sparks. Never switch lights or electrical appliances on or off.
 - Close the gas shut-off valve.
 - Open windows and doors.
 - Evacuate any people from the danger zone.
 - Notify your gas or electricity supply utility from outside the building.
 - Have the power supply to the building shut off from a safe place (outside the building).

If you smell flue gas

-  **Danger**
Flue gas can lead to life threatening poisoning.
- Shut down the heating system.
 - Ventilate the installation site.
 - Close doors to living spaces to prevent flue gases from spreading.

What to do if water escapes from the appliance

-  **Danger**
If water escapes from the appliance there is a risk of electrocution. Switch OFF the heating system at the external isolator (e.g. fuse box, domestic distribution board).

-  **Danger**
If water escapes from the appliance there is a risk of scalding. Never touch hot heating water.

Condensate

-  **Danger**
Contact with condensate can be harmful to health. Never let condensate touch your skin or eyes and do not swallow it.

Flue systems and combustion air

Ensure that flue systems are clear and cannot be sealed, for instance due to accumulation of condensate or other external causes. Ensure an adequate supply of combustion air. Inform system users that subsequent modifications to the building characteristics are not permissible (e.g. cable/pipe-work routing, cladding or partitions).

-  **Danger**
Leaking or blocked flue systems, or an inadequate supply of combustion air can cause life threatening poisoning from carbon monoxide in the flue gas. Ensure the flue system is in good working order. Vents for supplying combustion air must be non-sealable.

Extractors

Operating appliances that extract air to the outside (extractor hoods, extractors, air conditioning units, central vacuum cleaning systems, etc.) can create negative pressure. If the boiler is operated at the same time, this can lead to a reverse flow of flue gas.

Safety instructions (cont.)**Danger**

The simultaneous operation of the boiler and appliances that exhausts air to the outside can result in life threatening poisoning due to a reverse flow of flue gas.

Fit an interlock circuit or take suitable steps to ensure an adequate supply of combustion air.









1. Information	Disposal of packaging	8
	Symbols	8
	Intended use	8
	Product information	9
	■ Vitodens 200-W, type B2HF, B2KF	9
	System examples	10
	Maintenance parts and spare parts	10
	■ Viessmann Partnership	10
	■ Viessmann spare part app	10
2. Preparing for installation	11
3. Installation sequence	Mounting the boiler and making connections	14
	■ Removing the front panel	14
	■ Mounting the boiler on the pre-plumbing jig or mounting frame	14
	■ Fitting the boiler to the wall mounting bracket	16
	■ Fitting the programming unit mounting bracket on the top of the boiler	18
	■ Connections on the heating water and DHW sides	19
	Condensate connection	20
	■ Filling the trap with water	20
	Flue gas connection	20
	Gas connection	22
	Electrical connections	23
	■ Opening the wiring chamber	23
	■ Layout of the electrical connections	24
	■ On-site connections on HMU heat management unit	25
	■ Outside temperature sensor 1	25
	■ Connecting low loss header sensor 9	26
	■ Connecting the cylinder temperature sensor	26
	■ Connecting the circulation pump to P1 and P2	26
	■ Floating switching contact connection	26
	■ Information on connecting PlusBus subscribers	27
	■ Checking the CAN bus terminator switch setting	27
	■ Power supply for accessories at plug 96 / 156 (230 V ~)	28
	■ Power supply 40	29
	■ Routing connecting cables/leads	30
	WiFi operational reliability and system requirements	31
	■ Wireless signal range of WiFi connection	31
	■ Angle of penetration	31
	Closing the wiring chamber	32
	Fitting the programming unit and front panel	33
	■ Programming unit located at the bottom	33
	■ Programming unit located at the top	34
4. Commissioning, inspection, maintenance	Steps - commissioning, inspection and maintenance	35
5. System configuration (parameters)	Calling up parameters	62
	General	62
	Boiler	64
	DHW	66
	Heating circuit 1, Heating circuit 2, Heating circuit 3, Heating circuit 4 ..	68
	■ Energy saving functions (setting only via software tool)	75
	■ Parameter setting only via software tool	77
	Solar	78
	Subscriber numbers of connected extensions	81
6. Diagnosis and service checks	Service menu	83
	■ Calling up the service menu	83

	Exiting the service menu	84
	Changing the service password	84
	Resetting all passwords to delivered condition	84
	Diagnosis	84
	■ Checking operating data	84
	Calling up messages (message history)	85
	Checking outputs (actuator test)	85
7. Troubleshooting	Fault display on the programming unit	88
	Overview of electronics modules	89
	Fault messages	89
	Further messages	112
	■ Service messages	112
	■ Status messages	112
	■ Warning messages	113
	■ Information	113
	Repairs	114
	■ Shutting down the boiler	114
	■ Removing the boiler from the pre-plumbing jig or mounting frame	115
	■ Status/checking/diagnosing the internal circulation pump	115
	■ Checking the temperature sensors	117
	■ Information on replacing the HMU heat management unit and BCU burner control unit	121
	■ Replacing the power cable	121
	■ Replacing the HMI connecting cable	121
	■ Checking the plate heat exchanger	121
	■ Removing the hydraulic unit	122
	■ Checking the fuse	124
8. Function description	Appliance functions	125
	■ Heating mode	125
	■ Venting program	125
	■ Filling program	125
	■ Heating curve	125
	■ Screed drying	127
	■ Raising the reduced room temperature	129
	DHW heating (system boilers only)	131
	Increased DHW hygiene	131
	Interval function, solar circuit pump	132
	External heating circuit hook-up (if installed)	132
9. Connection and wiring diagram	HMU heat management unit	133
	BCU burner control unit	135
10. Commissioning/service reports	136
11. Specification	Specification	137
	Electronic combustion control unit	145
12. Disposal	Final decommissioning and disposal	146
13. Ordering individual parts	Ordering individual parts for accessories	147
14. Certificates	Declaration of conformity	148
	Manufacturer's certificate according to the 1st BImSchV [Germany]	148
15. Keyword index	149







Disposal of packaging

Please dispose of packaging waste in line with statutory regulations.

Symbols

Symbol	Meaning
	Reference to other document containing further information
	Step in a diagram: The numbers correspond to the order in which the steps are carried out.
	Warning of material losses and environmental pollution
	Live electrical area
	Pay particular attention.
	<ul style="list-style-type: none"> Component must audibly click into place. or Acoustic signal
	<ul style="list-style-type: none"> Fit new component. or In conjunction with a tool: Clean the surface.
	Dispose of component correctly.
	Dispose of component at a suitable collection point. Do not dispose of component in domestic waste.

The steps in connection with commissioning, inspection and maintenance are found in the "Commissioning, inspection and maintenance" section and identified as follows:

Symbol	Meaning
	Steps required during commissioning
	Not required during commissioning
	Steps required during inspection
	Not required during inspection
	Steps required during maintenance
	Not required during maintenance

Intended use

The appliance is intended solely for installation and operation in sealed unvented heating systems that comply with EN 12828, with due attention paid to CECS 215-2017 and the associated installation, service and operating instructions. It is only designed for heating up heating water that is of potable water quality.

Intended use presupposes that a fixed installation in conjunction with permissible, system-specific components has been carried out.

The appliance is intended exclusively for domestic or semi-domestic use; even users who have not had any instruction are able to operate the appliance safely.

Commercial or industrial usage for a purpose other than heating the building or DHW shall be deemed inappropriate.

Any usage beyond this must be approved by the manufacturer in each individual case.

Intended use (cont.)

Incorrect usage or operation of the appliance (e.g. the appliance being opened by the system user) is prohibited and will result in an exclusion of liability. Incorrect usage also occurs if the components in the heating system are modified from their intended use (e.g. if the flue gas and ventilation air paths are sealed).

Product information

Vitodens 200-W, type B2HF, B2KF

Wall mounted gas condensing boiler with Inox-Radial heat exchanger and the following integrated components:

- Modulating MatriX-Plus burner for natural gas and LPG
- Hydraulics with 3-way diverter valve and variable speed high efficiency circulation pump
- Type B2KF: Plate heat exchanger for DHW heating
- Weather-compensated or constant temperature control unit
- Integral diaphragm expansion vessel (10 l capacity)

The selected gas category in the delivered condition and the associated nominal gas pressure are given on the boiler type plate. The type plate also shows the other gas types and pressures with which the boiler can be operated. A conversion within the stated natural gas groups is not required. For conversion to LPG (without conversion kit), see "Commissioning, inspection and maintenance".

Type plate

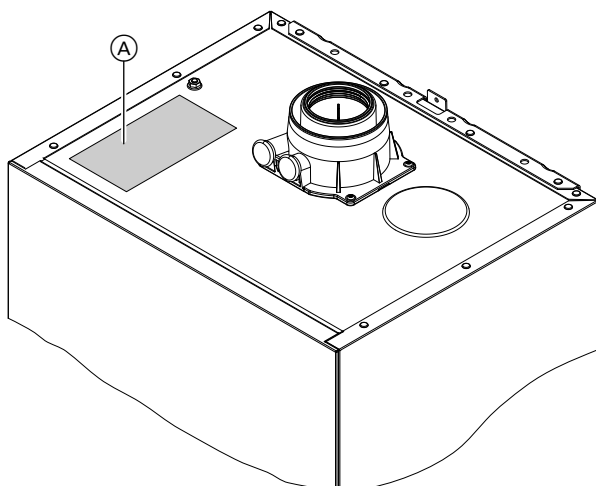

Fig. 1

- Ⓐ Type plate with QR code for appliance registration

The type plate of the heat generator contains extensive product information and an appliance-specific **QR code with the marking "i"** for direct access to product-specific information and product registration on the internet.

The QR code contains the credentials for the registration and product information portal, and the 16-digit serial number.

Note

A further label with the QR code is enclosed with the heat generator.

Stick the label in the installation and service instructions so it can be easily found again for later use.

The Vitodens 200-W may only be delivered to countries listed on the type plate. For deliveries to other countries, approved contractors must arrange individual approval on their own initiative and in accordance with the law of the country in question.

System examples

System examples with hydraulic and electrical connection diagrams and function descriptions are available to help setting up the heating system.

Detailed information regarding system examples:
www.viessmann-schemes.com

Maintenance parts and spare parts

Maintenance parts and spare parts can be identified and ordered directly online.

Viessmann Partnership

Login:
<https://shop.viessmann.com/>



Viessmann spare part app

www.viessmann.com/etapp



Preparing for installation

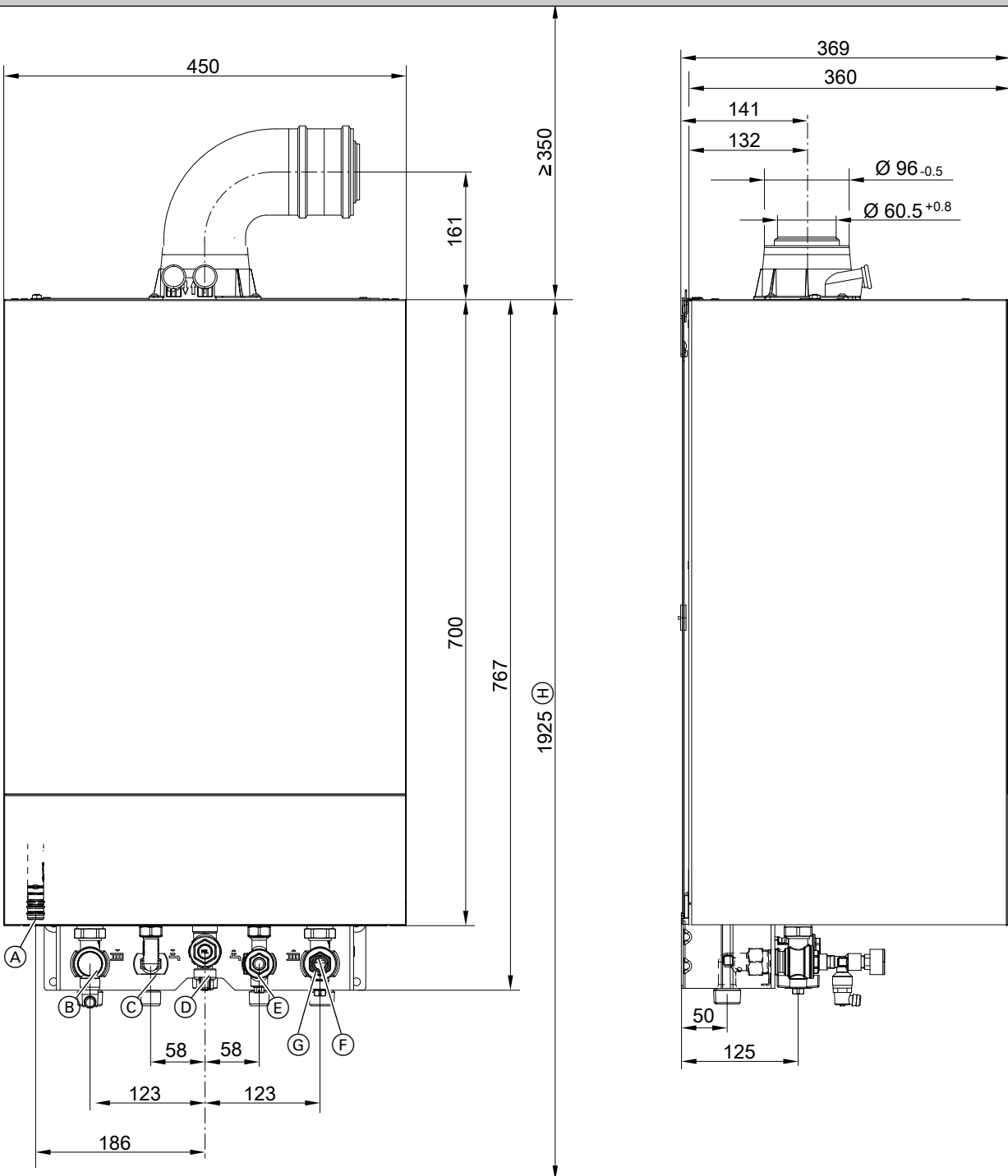

Installation

Fig. 2 Illustration shows a gas condensing combi boiler

- (A) Condensate drain
- (B) Heating flow
- (C) DHW (gas condensing combi boiler)
Cylinder flow (gas condensing system boiler)
- (D) Gas connection
- (E) Cold water (gas condensing combi boiler)
Cylinder return (gas condensing combi boiler)
- (F) Heating return
- (G) Filling/draining
- (H) Dimension for installation with DHW cylinder below the boiler

Preparing for installation (cont.)

Note

This boiler (IP rating: IP X4) is approved for installation in wet rooms inside safety zone 1, to DIN VDE 0100. Exposure to jets of water must be prevented. For open flue operation, the boiler may only be operated with a splash cover. Observe the requirements of DIN VDE 0100.

1. Subject to order: Fit supplied pre-plumbing jig, mounting frame or wall mounting bracket in the relevant installation location.



Installation instructions for pre-plumbing jig or mounting frame

Note

Check the condition of the wall where the boiler is to be installed. For the suitability of the supplied rawl plugs for various building materials, see manufacturer's instructions: Fischer Spreizdübel SX 10 x 80. For other construction materials, use fixing materials with sufficient load bearing capacity.

2. Prepare the water connections to the valves/fittings of the mounting bracket. Thoroughly flush the heating system.



Please note

To prevent appliance damage, connect all pipework free of load and torque stress.

Note

To prevent dirt from entering the connections: Do not remove the protective caps until you are about to fit the boiler.

Note

If an on-site expansion vessel also has to be installed: Install this expansion vessel in the cylinder return, as the 3-way diverter valve is located in the heating flow. Not possible with combi appliances!

Note

When installing a combi appliance in a basement, an additional shut-off valve can be installed in the DHW line. This enables easier maintenance.

3. Prepare the gas connection according to TRGI or TRF [or local regulations].

4. Prepare the electrical connections.

- The appliance is delivered fitted with a power cable (approx. 2 m long).

Note

Connect the power cable to the electricity supply using a fixed connection.

- Power supply: 230 V, 50 Hz, fuse rating max. 16 A
- Accessory cables: 0.75 mm² flexible PVC cable with required number of cores for external connections

Preparing for installation (cont.)

Connection on the DHW side for gas condensing combi boiler

Cold water installation

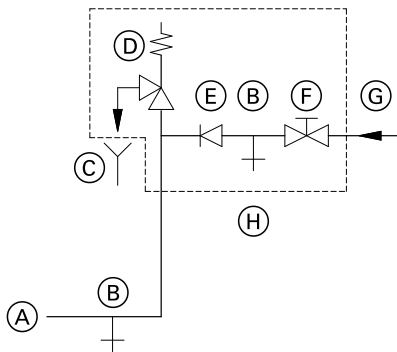

Fig. 3

- Ⓐ Cold water connection of boiler
- Ⓑ Drain outlet
- Ⓒ Visible discharge pipe outlet point
- Ⓓ Safety valve
- Ⓔ Non-return valve
- Ⓕ Shut-off valve
- Ⓖ Cold water
- Ⓗ Safety assembly

Safety assembly Ⓗ is included in the standard delivery and requires installing.

Only use a non-return valve or a combined shut-off and non-return valve in conjunction with a safety valve. If the safety valve is used, the cold water shut-off valve on the boiler must not be shut off. Remove the toggle on the cold water shut-off valve (if installed) to prevent it being shut off manually.

Shock arrestor

If draw-off points likely to cause water hammer are connected to the boiler's DHW network (e.g. flush valves, washing machines, dishwashers): Shock arrestors should be installed close to the cause of the water hammer.

Removing the front panel

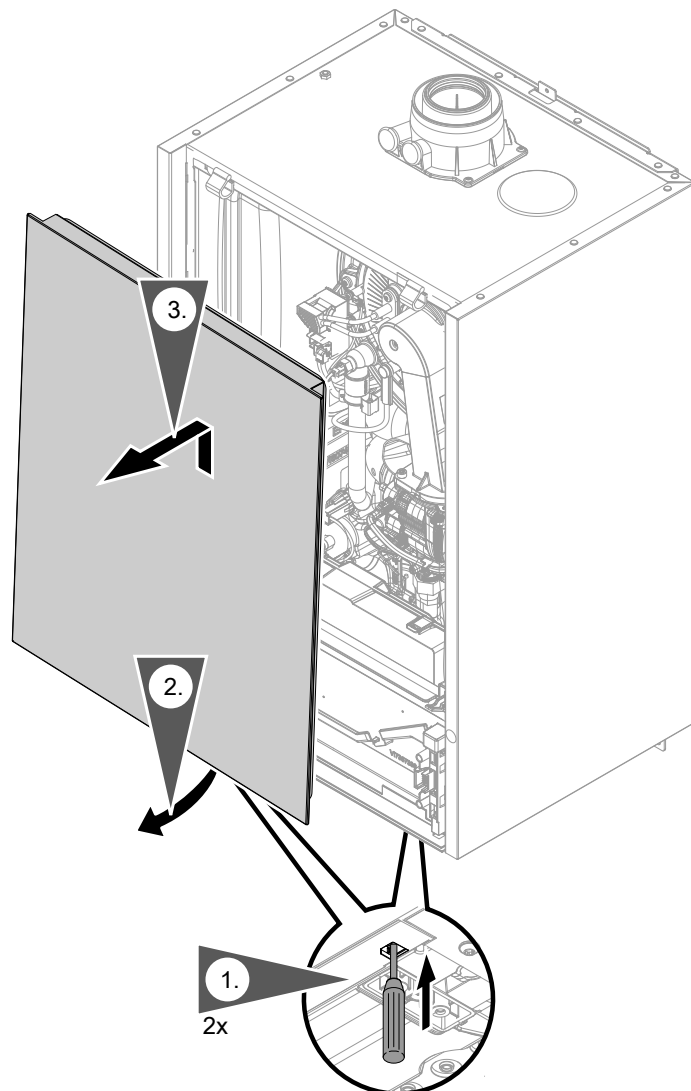

Fig. 4

1. Unlock the front panel on the underside (push in), using a screwdriver or similar tool.
2. Swivel the front panel forwards slightly and lift away upwards.

Note

Do not remove protective caps from connections on the heating water side and from the gas connection until you are about to commence installation.

Mounting the boiler on the pre-plumbing jig or mounting frame

Note

Various installation components can be found in a separate pack. Keep the installation components safe, as they will be required for later installation.

Mounting the boiler and making connections (cont.)

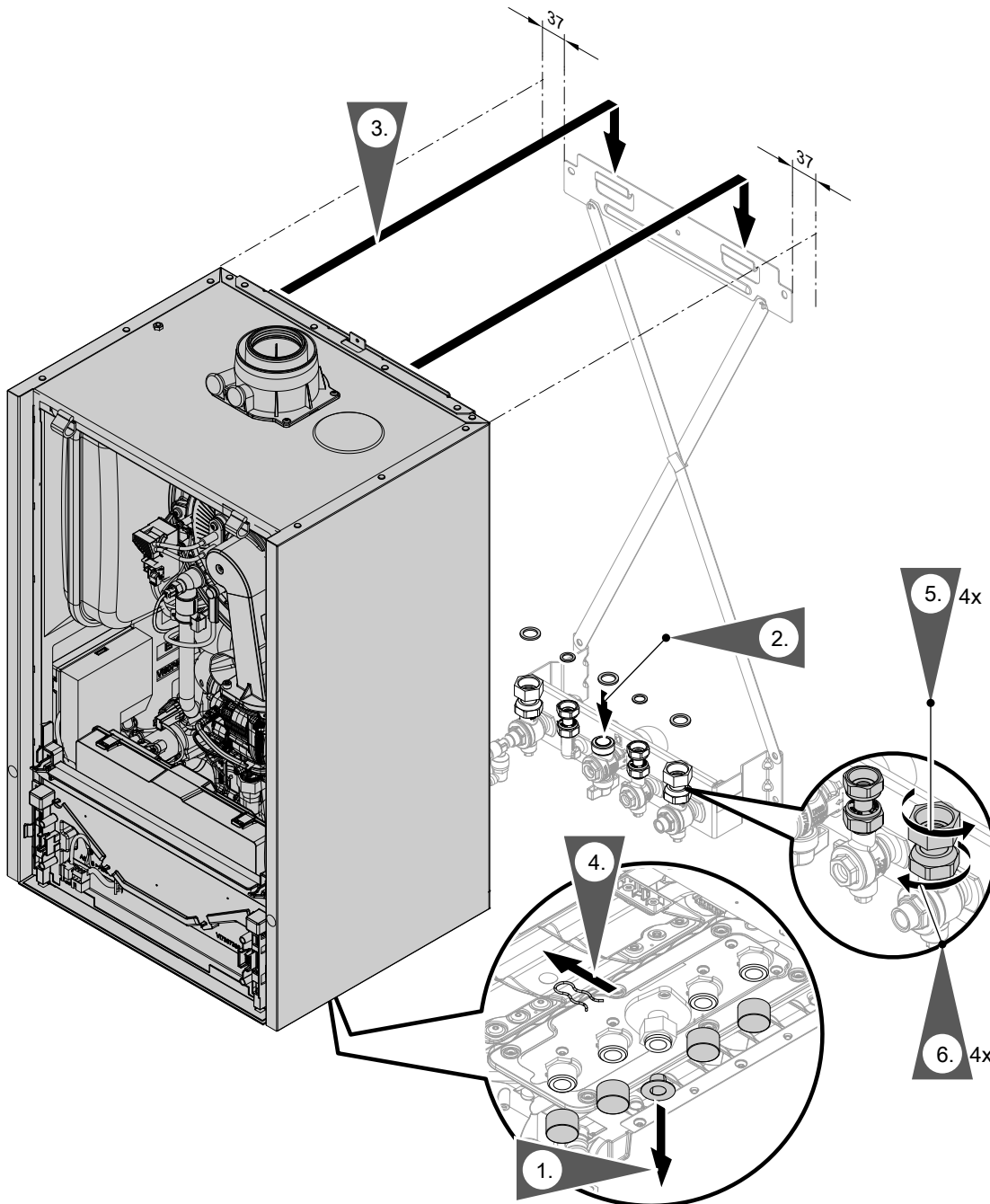

Fig. 5

Note

The diagram shows installation on a pre-plumbing jig for a gas condensing combi boiler.

The boiler can be installed on the following accessories:

- Pre-plumbing jig
- Pre-plumbing jig for sub-mounting kit
- Mounting frame
- Plumbing wall mounting frame

1. Pull off the protective caps.

2. Replace gaskets.

Internal gasket diameter:

- Gas connection Ø 18.5 mm
- Connections on the heating water side Ø 17.0 mm

Note

Gasket for gas connection is attached to the gas shut-off valve.

3. Suspend the Vitodens from the wall mounting bracket.

Note

After mounting, ensure correct seating.

Mounting the boiler and making connections (cont.)

4. **Note**

Only remove the clip under the gas pipe union nut once the appliance has been installed. Clip is no longer required.

5. Tighten union nuts so that they form a tight seal.

Torque settings:

- Union nuts G $\frac{3}{4}$: 30 Nm
- Union nuts G $\frac{1}{2}$: 24 Nm

When carrying out any work on gas connection fittings, counterhold with a suitable tool. Never transfer any forces to the internal components.

6. Tighten locking ring fittings so that they form a tight seal:
One turn beyond finger-tight.

Fitting the boiler to the wall mounting bracket

Note

Various installation components can be found in a separate pack. Keep the installation components safe, as they will be required for later installation.

Mounting the boiler and making connections (cont.)

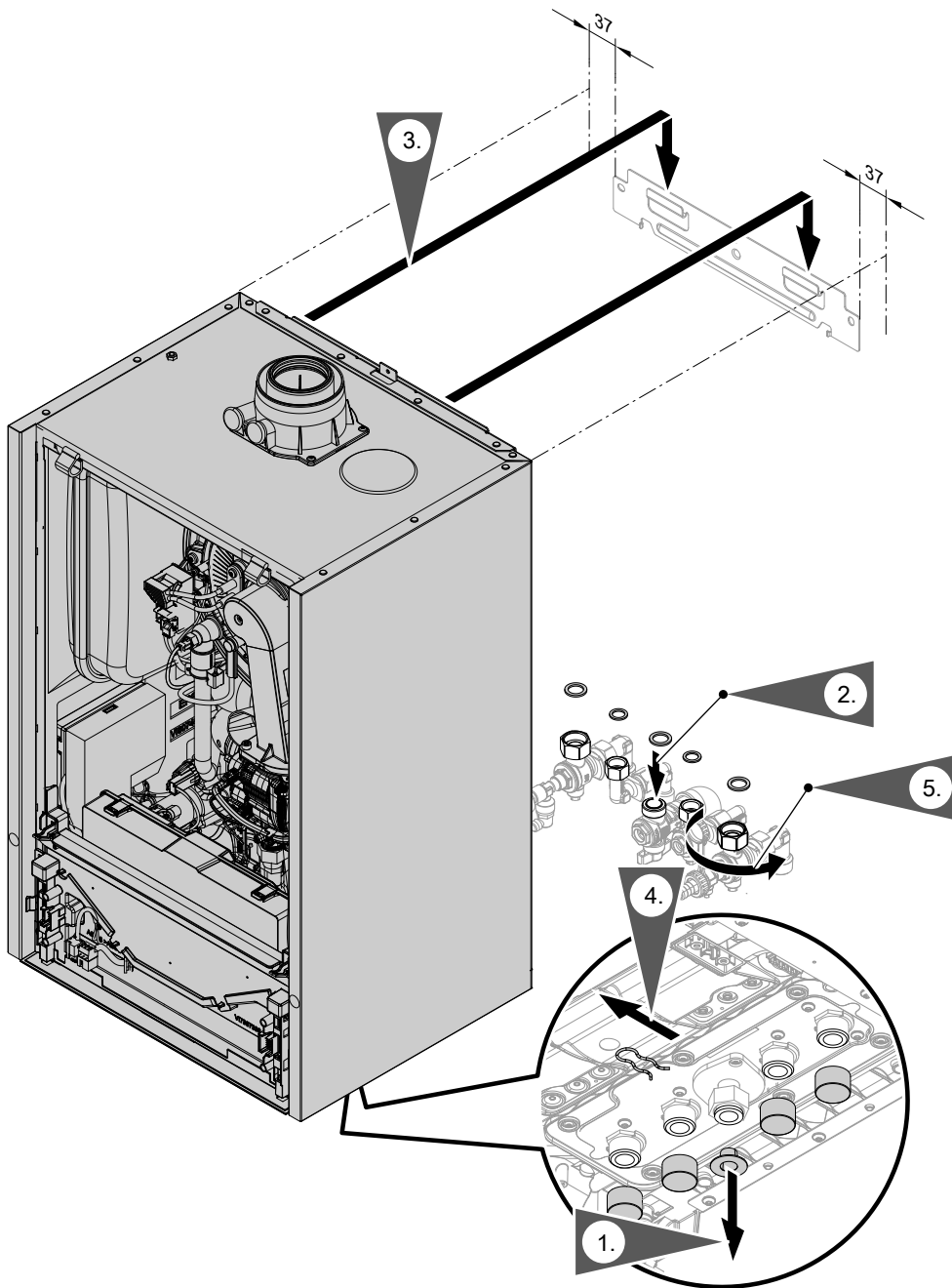

Fig. 6

1. Pull off the protective caps.
2. Replace gaskets. Fit valves and gas shut-off valve.

Internal gasket diameter:

- Gas connection $\text{\O} 18.5 \text{ mm}$
- Connections on the heating water side $\text{\O} 17.0 \text{ mm}$

Note

Gasket for gas connection is attached to the gas shut-off valve.

3. Suspend the Vitodens from the wall mounting bracket.

4. Note

Only remove the clip under the gas pipe union nut once the appliance has been installed. Clip is no longer required.

5. Torque settings:

- Union nuts G $\frac{3}{4}$: 30 Nm
- Union nuts G $\frac{1}{2}$: 24 Nm

When carrying out any work on gas connection fittings, counterhold with a suitable tool. Never transfer any forces to the internal components.

Fitting the programming unit mounting bracket on the top of the boiler

In the delivered condition, the programming unit is located on the underside of the boiler. If required for ease of operation, the programming unit can be located on the top of the boiler. To do so, reposition the bracket at the top.

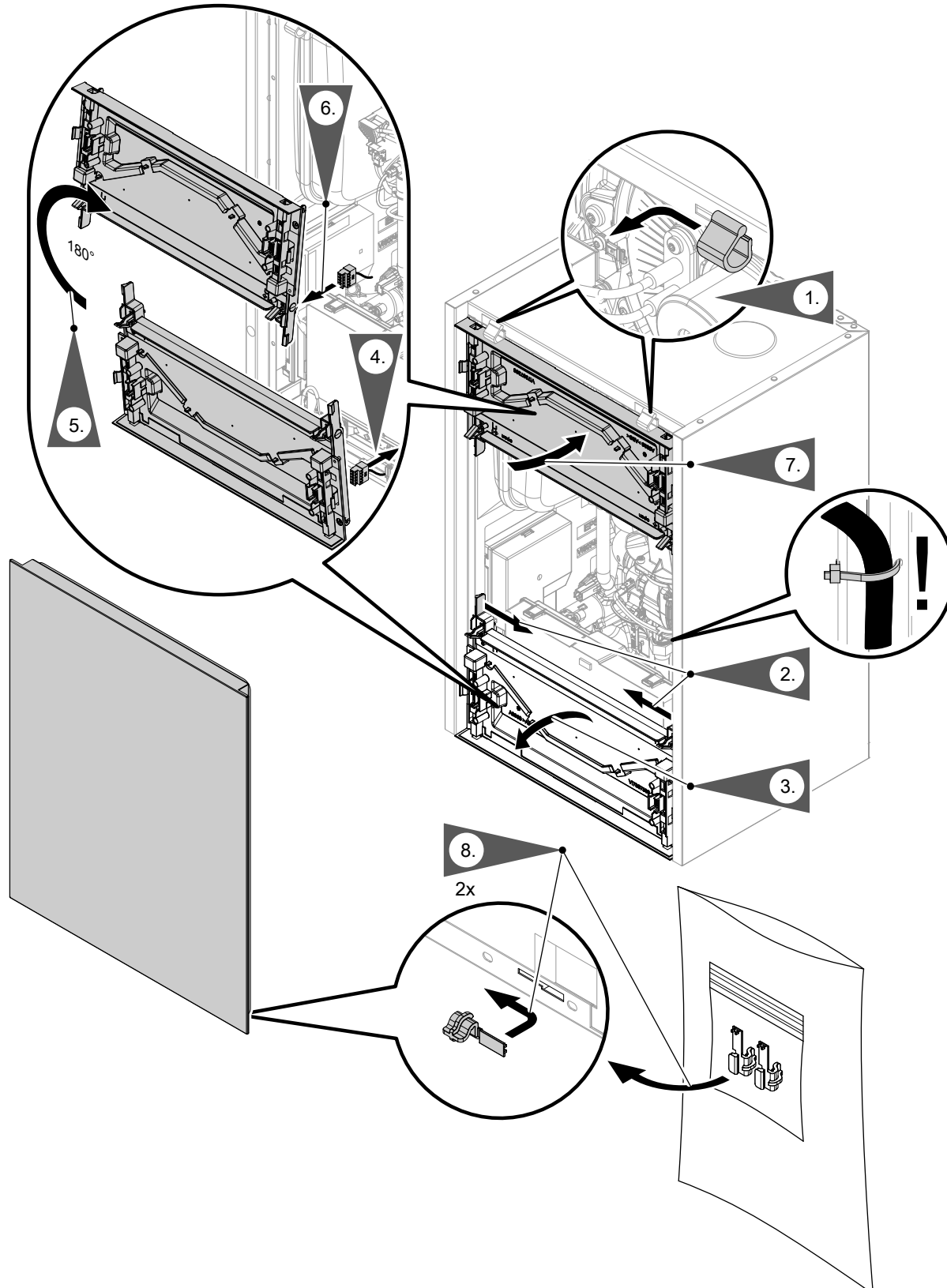

Installation

Fig. 7
18

Mounting the boiler and making connections (cont.)

1. Remove the hinges and store them in case they need to be reinstalled at a later date.
4. Pull the plug of the connecting cable from the bracket.
6. Turn the bracket over and insert the plug on the right-hand side again.

! Please note
 Incorrect routing of the cable can lead to heat damage and impairment of the EMC properties.
 Do not change the position of the cable or its fixture (fixing point on casing).

Connections on the heating water and DHW sides

If the connections have not been fitted previously, make the connections on the heating water and DHW sides.

Gas condensing system boiler

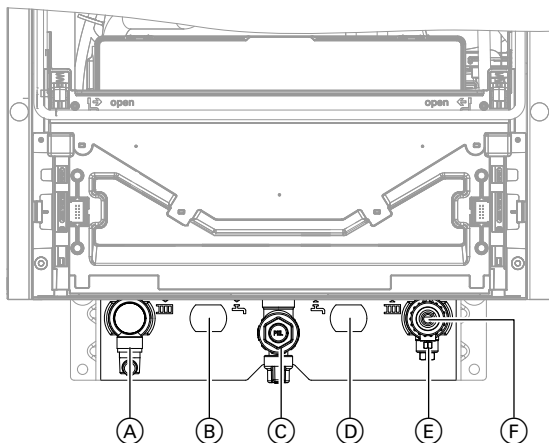

Fig. 8 Specifications for threads in conjunction with connection accessories

- (A) Heating flow R $\frac{3}{4}$ (male thread)
- (B) Cylinder flow G $\frac{3}{4}$ (male thread)
- (C) Gas connection R $\frac{3}{4}$ (male thread)
- (D) Cylinder return G $\frac{3}{4}$ (male thread)
- (E) Heating return R $\frac{3}{4}$ (male thread)
- (F) Filling/draining

Connection on the heating water side of the DHW cylinder:

The required intermediate pieces (Rp $\frac{3}{4}$, female thread) on the cylinder flow and return are part of the connection set for the DHW cylinder.

If no DHW cylinder is being connected, seal off the connections with caps.

Gas condensing combi boiler

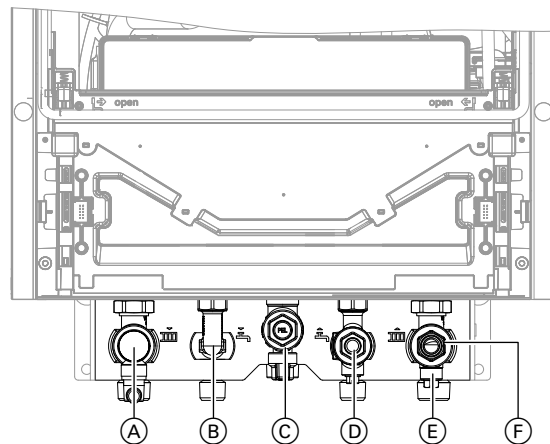

Fig. 9 Specifications for threads in conjunction with connection accessories

- (A) Heating flow R $\frac{3}{4}$ (male thread)
- (B) DHW R $\frac{1}{2}$ (male thread)
- (C) Gas connection R $\frac{3}{4}$ (male thread)
- (D) Cold water R $\frac{1}{2}$ (male thread)
- (E) Heating return R $\frac{3}{4}$ (male thread)
- (F) Filling/draining

Scald protection

DHW temperatures of over 60 °C can occur with gas condensing combi boilers. As a result, scald protection should be installed on site in the DHW pipe.

Condensate connection

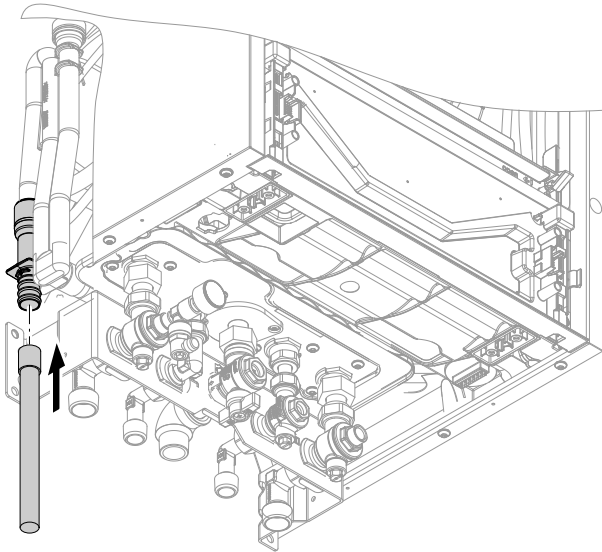

Fig. 10

1. Push the supplied drain hose on to the drain connector.
2. Connect the drain hose with a constant fall and a pipe vent to the public sewage system or to a neutralising system.

Note

Route the onward drain line inside the building as far as possible.

If the onward drain line is routed outside the building:

- Use a min. Ø 30 mm line.
- Protect the line from frost.
- Keep the line as short as possible.



Please note

The drain hose is used to route away any hot water discharged from the safety valve. Lay and secure the drain hose in a way that prevents any risk of scalding.

Note

Observe local waste water regulations.

Filling the trap with water

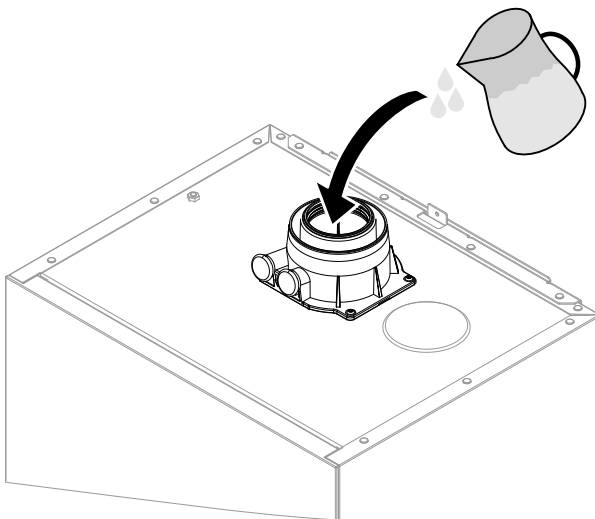

Fig. 11

Pour at least 0.3 l of water into the flue gas connection.



Please note

During commissioning, flue gas may escape from the condensate drain. Always fill the trap with water before commissioning.

Note

If there is a risk of frost, only fill the trap just before commissioning.

Flue gas connection

Note

The "System certification" and "Skoberne GmbH flue system" labels enclosed with the technical documentation may only be used in conjunction with the Viessmann flue system made by Skoberne.



Connecting the balanced flue pipe

Flue system installation instructions

Flue gas connection (cont.)

Connecting several Vitodens to a shared flue system

If connecting multiple Vitodens to a common flue system at positive pressure using routing types C₁₀, C₁₁, C₁₃, C₁₄: Install a back draught safety device (accessories) in the flue gas connection and the mixing shaft of the burner on each boiler.

Installing the back draught safety devices:



Installation instructions for back draught safety device

Converting the control unit for use with a shared flue system:

- In the commissioning assistant, select the **"Multiple connections"** setting under **"Flue system type"**.

Do not carry out **commissioning** until the following conditions are met:

- Free passage through the flue gas pipes.
- Flue system with positive pressure is gas-tight.
- Inspection port covers checked for secure and tight seating.

- Apertures for ensuring sufficient combustion air supply are open and cannot be closed off.

Note

In open flue operation, install a rodent guard grille on the supply air aperture.

- Applicable regulations on installing and commissioning flue systems have been followed.
- Visual inspection of the flue gas connection.

Note

The use of lubricant prevents the gasket from shifting when the flue pipe is installed.

When using a straight flue pipe, check that the inner ventilation air pipe is correctly fitted.



Danger

Leaking or blocked flue systems or an insufficient supply of combustion air cause life threatening poisoning due to carbon monoxide in the flue gas.

Ensure the flue system is in good working order. Vents for interconnected combustion air supply must be non-closable in open flue operation. Prevent condensate drainage via a wind protector.

Gas connection

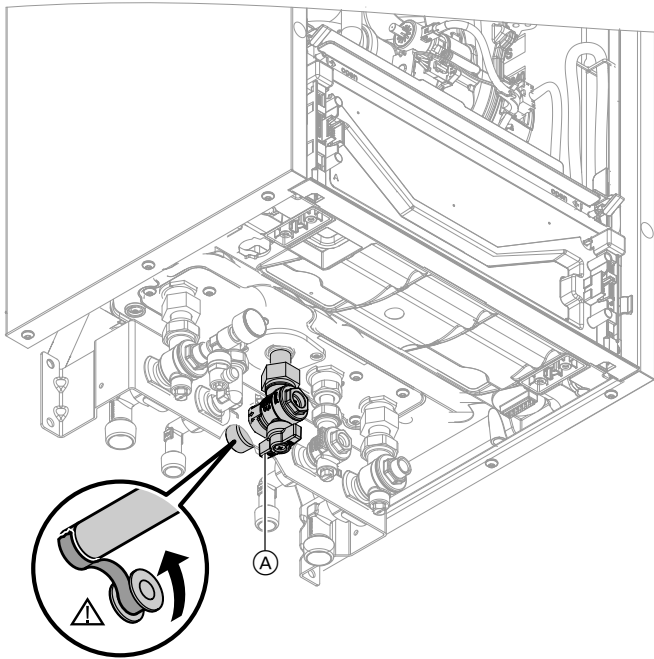

Fig. 12

1. If the gas connection has not been fitted previously, seal gas shut-off valve (A) to the gas connection.
When carrying out any work on gas connection fittings, counterhold with a suitable tool. Never transfer any forces to the internal components.

Information on operation with LPG

Install an external safety solenoid valve if the boiler is installed below ground level.

An EM-EA1 extension (accessories) is required to connect the safety solenoid valve.

2. Check for leaks.



Danger

Escaping gas leads to a risk of explosion. Check all connections on the gas side (also inside the appliance) for tightness.

Note

Only use suitable and approved leak detection agents (EN 14291) and devices for the tightness test. Leak detection agents with unsuitable constituents (e.g. nitrides, sulphides) can cause material damage.

Remove residues of the leak detection agent after testing.



Please note

Excessive test pressure will damage the boiler and gas solenoid valve.

Max. test pressure 150 mbar (15 kPa). If a higher pressure is required for leak tests, disconnect the boiler and the gas solenoid valve from the main supply pipe (undo the fitting).

3. Purge the gas line.

Electrical connections

Opening the wiring chamber

Note

If only PlusBus, the outside temperature sensor and the cylinder temperature sensor are connected to the heat generator, the wiring chamber does not need to be opened.

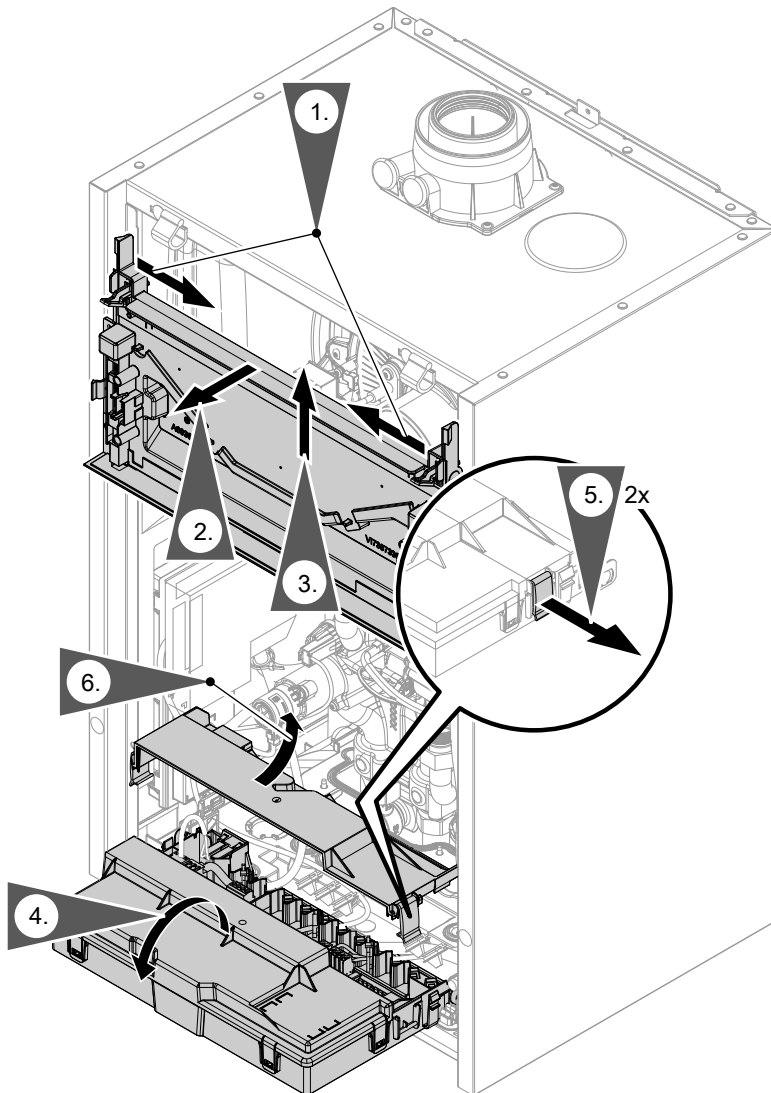

Fig. 13

Note

Steps 1 to 3 are required only if the programming unit is located at the bottom.

Do not disconnect the plug from the mounting panel.

Do not change the position of the cable or its fixture (fixing point on casing).



Please note

Electronic assemblies can be damaged by electrostatic discharge.

Prior to commencing any work, touch earthed objects, such as heating or water pipes to discharge static loads.

Layout of the electrical connections

Note

For further information on the connections, see the following chapters.

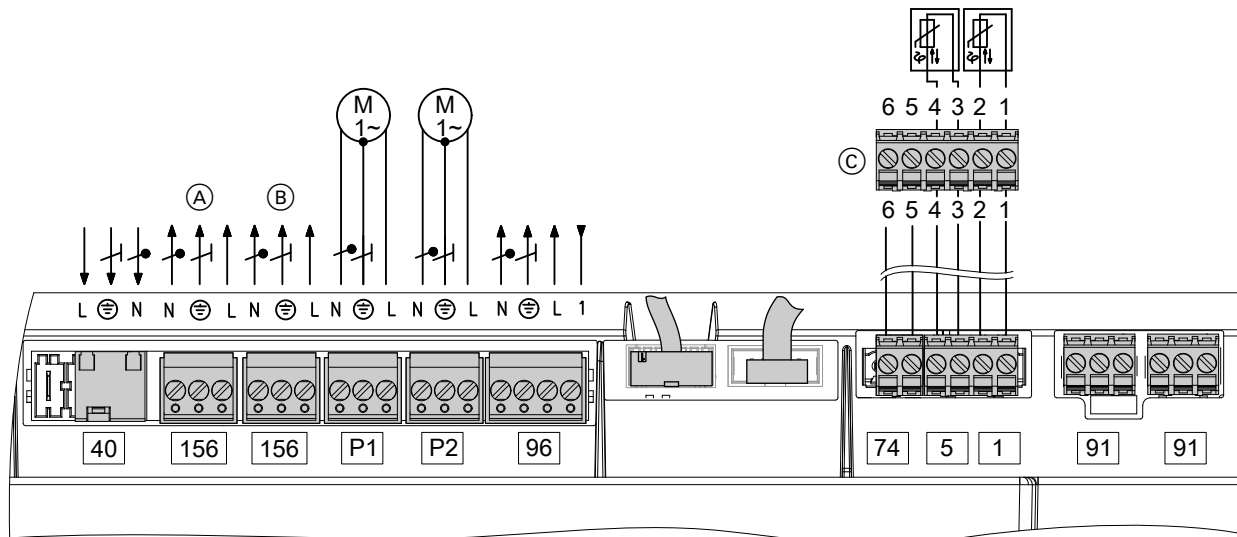

Fig. 14

Connections to 230 V~ plugs

- 40 Power supply
- 96 Configurable input 230 V, potential free
Output 230 V
- 156 Switched power outlet
- P1 Output 230 V for:
Circulation pump for cylinder heating or heating circuit pump for heating circuit without mixer or heating circuit pump for heating circuit without mixer A1, without low loss header and with no other heating circuits (max. 1 heating circuit in the system).
- P2 Output 230 V for:
Heating circuit pump for heating circuit without mixer or DHW circulation pump or heating circuit pump for heating circuit without mixer A1, without low loss header and with no other heating circuits (max. 1 heating circuit in the system).
- A BCU burner control unit power supply (connected in the delivered condition)

- B Power supply for accessories
- C External plug on underside of appliance (see also following diagram)

Connections to extra low voltage (ELV) plugs

- 1 Outside temperature sensor
Terminals 1 and 2 on external plug C
- 5 Cylinder temperature sensor
Terminals 3 and 4 on external plug C
- 74 PlusBus
Terminals 5 and 6 on external plug C
- 91 CAN bus



Information on connecting accessories

When connecting accessories observe the separate installation instructions provided with them.

Electrical connections (cont.)

On-site connections on HMU heat management unit

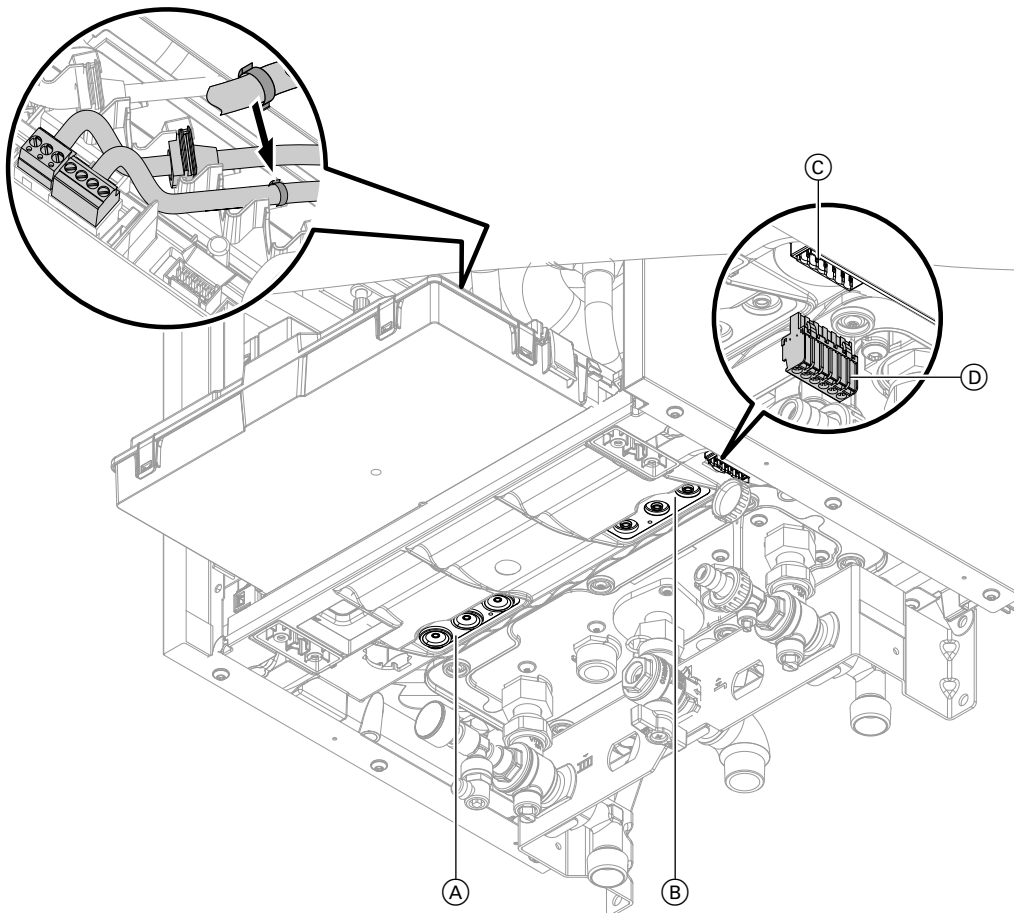

Fig. 15

- (A) Diaphragm grommets, 230 V cables
- (B) Diaphragm grommets, extra low voltage (ELV)
- (C) Plug-in connection on underside of appliance
- (D) Plug for connecting sensors and PlusBus
Remove plug from the pack of installation components.

- Open diaphragm grommets as required. Thread through only one cable at a time without a plug. Ensure diaphragm grommets are airtight. If required, remove plug from cable. After threading the cable through, re-fit the plug to the wire ferrules.
- Required plugs are supplied in separate packaging.
- For cables without strain relief bushings, provide strain relief in the wiring chamber in the form of cable ties.

Outside temperature sensor 1

Fitting location for outside temperature sensor

- North or north-westerly wall, 2 to 2.5 m above ground level; in multi storey buildings, in the upper half of the second floor
- Not above windows, doors or vents

- Not immediately below balconies or gutters
- Never render over

Outside temperature sensor connection

2-core lead, length up to 35 m with a cross-section of 1.5 mm²

Electrical connections (cont.)

Connecting low loss header sensor 9

The low loss header sensor is connected to accessory extension EM-P1 or EM-M1/MX (ADIO electronics module).



Installation instructions for extension EM-P1 or EM-M1/MX

Connecting the cylinder temperature sensor

Connect the cylinder temperature sensor to terminals 3 and 4 on external plug C. See page 24.

Connecting the circulation pump to P1 and P2

Note

Observe the priority of the connections.

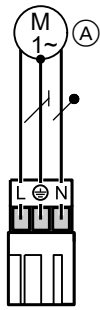

Fig. 16

- A Circulation pump
- B P1/P2 plug on HMU heat management unit

Possible connections to P1 and priority of connections:

1. Circulation pump for cylinder heating
2. If no circulation pump for cylinder heating is present:
 - Heating circuit pump for heating circuit without mixer A1 in connection with low loss header and heating circuits with mixer
 - Heating circuit pump for heating circuit without mixer A1, without low loss header and with no other heating circuits (max. 1 heating circuit in the system).

Possible connections to P2 and priority of connections:

1. Heating circuit pump for heating circuit without mixer A1 in connection with low loss header and heating circuits with mixer
2. Heating circuit pump for heating circuit without mixer A1, without low loss header and with no other heating circuits (max. 1 heating circuit in the system).
3. If no circulation pump for heating circuit without mixer is present:
 - DHW circulation pump

Note

If a heating circuit pump for heating circuit without mixer is installed, connect the DHW circulation pump to the P1 extension (accessories). Connect DHW circulation pumps with standalone functions directly to the 230 V~ supply.

The function of connections P1 and P2 is selected in the commissioning assistant by selecting the connected component in the system scheme.

Specification

Rated current	1 A
Rated voltage	230 V ~

Floating switching contact connection

Connection at plug 96

One of the following functions can be connected:

- External demand
- External blocking
- DHW circulation pump external demand (pushbutton function, pump runs for 5 min). Not for Vitodens 222-W.

- Room temperature controller (room thermostat)
 - In conjunction with operating mode Continuous operation with room temperature controller (not for Vitodens 3xx)
- For external heating circuit hook-up (if installed), see chapter "External heating circuit hook-up". Not for Vitodens 3xx.

Electrical connections (cont.)

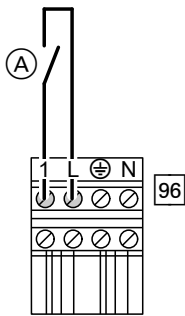

Fig. 17

(A) Floating contact

Assigning functions in the commissioning assistant

See commissioning assistant in "Commissioning".

Information on connecting PlusBus subscribers

Only the following PlusBus subscribers can be connected to the control:

- 2 x EM-M1 or EM-MX extensions (ADIO electronics module)
- 2 Vitotrol 200-E
- 3 x EM-EA1 extensions (DIO electronics module)

- 1 x EM-S1 extension (ADIO or SDIO/SM1A electronics module)
- 1 x EM-P1 extension (ADIO electronics module)

The max. total length of the PlusBus lead is 50 m. With an unscreened lead, 2-core, 0.34 mm².

Checking the CAN bus terminator switch setting

The CAN bus resistor is switched using switch (A) in the wiring chamber.

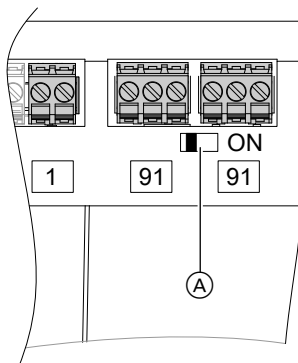

Fig. 18

- If the device is **not** integrated into a CAN bus system: Switch (A) must **not** be set to "ON".
- If the device is integrated into a CAN bus system and is located at the beginning or end of this system (not in the middle) of the CAN bus system (connected to only one plug 91): Set switch (A) to "ON".

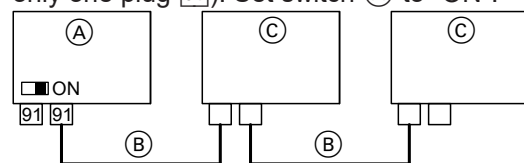

Fig. 19

- (A) Heat generator / HMU heat management unit
- (B) CAN bus cable
- (C) CAN bus other subscribers

- If the device is integrated into a CAN bus system and is **not** located at the beginning or end of the CAN bus system (both plugs 91 connected): Do **not** set switch (A) to "ON".

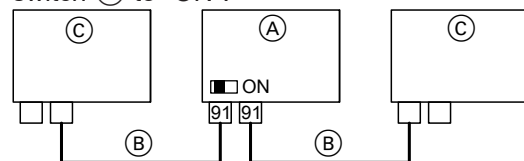

Fig. 20

Electrical connections (cont.)

Power supply for accessories at plug 96/156 (230 V ~)

When positioned in wet rooms, accessories outside the wet area must not be connected to the power supply at the HMU heat management unit. If the boiler is not sited in a wet room, the power supply for accessories can be connected directly to the HMU heat management unit. This connection is switched directly with the ON/OFF switch of the appliance.

If the total system current exceeds 6 A, connect one or more extensions directly to the mains supply via an ON/OFF switch (see next chapter).

Power supply and PlusBus connection of accessories

Power supply of all accessories at the HMU heat management unit

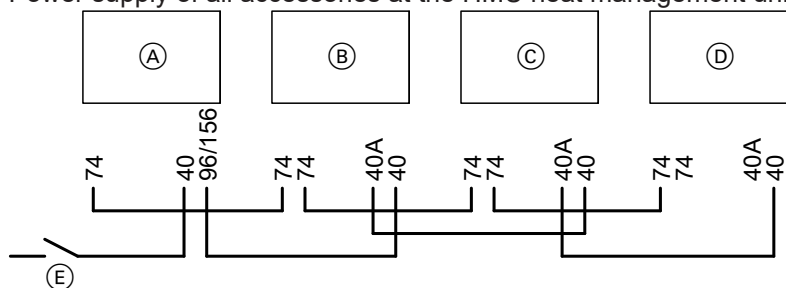

Fig. 21

Some accessories with direct power supply

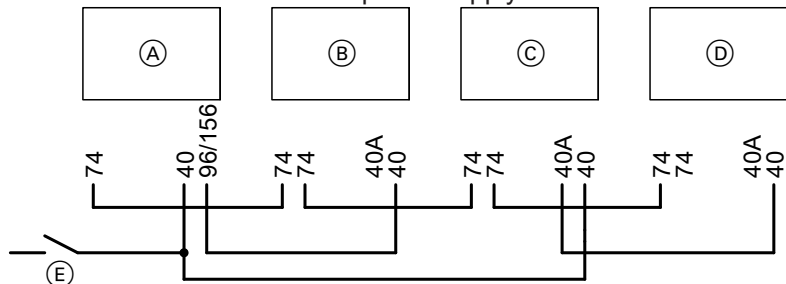

Fig. 22

- (A) HMU heat management unit, heat generator
- (B) Mixer extension kit (ADIO electronics module)
- (C) Mixer extension kit (ADIO electronics module)
- (D) EM-EA1 extension (DIO electronics module) and/or EM-S1 extension (ADIO or SDIO/SM1A electronics module)
- (E) ON/OFF switch
- 40 Mains input
- 40A Power outlet
- 74 PlusBus
- 96/156 Power outlet on HMU heat management unit

PlusBus system length max. 50 m for 0.34 mm² cable cross-section and unshielded cable.

If the current flowing to the connected working parts (e.g. circulation pumps) is higher than the fuse rating of the relevant accessory, only use the output concerned to control an on-site relay.

Accessories	Internal fuse protection
EM-M1, EM-MX mixer extension kit	2 A
EM-EA1 extension	2 A
EM-S1 extension (not for Vitodens 222-F, 222-W and 333-F)	2 A



Danger

Incorrect wiring can lead to serious injury from electrical current and result in appliance damage.

- Route extra low voltage (ELV) leads < 42 V separately from cables > 42 V/230 V~.
- Only strip the minimum of insulation from cables as close as possible to the terminals and bundle tightly to the corresponding terminals.
- Secure cables with cable ties.

Electrical connections (cont.)**Power supply** 40**Danger**

Incorrectly executed electrical installations can result in injuries from electrical current and damage to the appliance.

Connect the power supply and implement all safety measures (e.g. RCD circuit) in accordance with the following regulations:

- IEC 60364-4-41
- IEEE Wiring Regulation; BS 7671:2018
- Connection conditions of the local grid operator

- Install an isolator in the power cable to provide omnipolar separation from the mains for all active conductors, corresponding to overvoltage category III (3 mm) for complete isolation. The isolator must be fitted in the permanent electrical installation, in line with installation requirements.

We also recommend installing a pulse current-sensitive RCD (RCD class A .

- Connect the power cable to the electricity supply using a fixed connection.

- If the power supply to the appliance is connected with a flexible power cable, ensure that the live conductors are pulled taut before the earth conductor in the event of strain relief failure. The length of the earth conductor wire will depend on the design.
- Max. fuse rating 16 A.

**Danger**

The absence of system component earthing can lead to serious injury from electric current if an electrical fault occurs.

The appliance and pipework must be connected to the equipotential bonding of the building.

Routing connecting cables/leads

- ! **Please note**
If closures or diaphragm grommets are damaged, splashproofing is no longer ensured. Never open or damage closures or unused diaphragm grommets on the underside of the appliance. Seal cable entries with fitted diaphragm grommets.

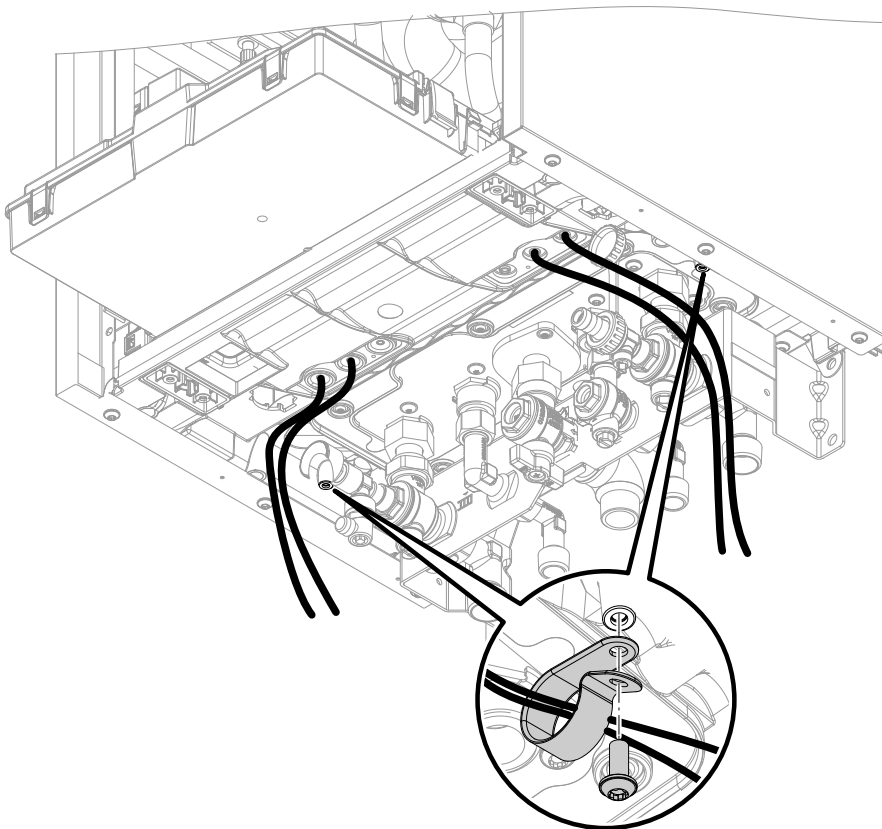

Fig. 23

Bundle cables using the supplied cable clips.
Route extra low voltage (ELV) leads < 42 V separately from cables > 42 V/230 V~.
Secure the cable clips on the underside using the supplied screws.
Do not route cables over sharp edges.

- ! **Please note**
If connecting cables/leads come into contact with hot components, they will be damaged. When routing and securing cables/leads on site, ensure that the maximum permissible temperatures for these cables/leads are not exceeded.

WiFi operational reliability and system requirements

WiFi router system requirement

- WiFi router with activated WiFi:
The WiFi router must be protected by a sufficiently secure WPA2 password.
The WiFi router must always have the latest firm-ware update.
Do not use unencrypted connections between the heat generator and the WiFi router.
- Internet connection with high availability:
Flat rate (flat rate tariff **without** restriction on time or data volume)
- Dynamic IP addressing (DHCP, delivered condition) in the network (WiFi):
Have this checked on site by an IT expert **prior** to commissioning. Arrange for set up if required.
- Set routing and security parameters in the IP network (LAN).
Enable the following ports for direct outgoing connections:
 - Port 80
 - Port 123
 - Port 443
 - Port 8883
 Have this checked on site by an IT expert **prior** to commissioning. Set up enabling if required.

Wireless signal range of WiFi connection

The range of wireless signals may be reduced by walls, ceilings and interior fixtures. These weaken the wireless signal, causing poor reception due to the following circumstances.

- On their way between transmitter and receiver, wireless signals are **damped**, e.g. by air or when penetrating walls.
- Wireless signals are **reflected** by metallic objects, e.g. reinforcements embedded in walls, metal foil of thermal insulation and thermal glazing with metalised thermal vapour deposit.
- Wireless signals are **isolated** by service ducts and lift shafts.
- Wireless signals are **disrupted** by devices that also operate with high frequency signals. Maintain a distance of **at least 2 m** from these devices:
 - Computers
 - Audio and video systems
 - Devices with active WiFi connection
 - Electronic transformers
 - Pre-ballasts

Install the heat generator as close as possible to the WiFi router to ensure a good WiFi connection. The signal strength can be displayed on the programming unit: See operating instructions.

Note

The WiFi signal strength can be increased with commercially available WiFi repeaters.

Angle of penetration

The reception quality remains best if radio signals hit the walls vertically.

Depending on the angle of penetration, the effective wall thickness changes and so does the extent to which the electromagnetic waves are damped.

Flat (unfavourable) angle of penetration

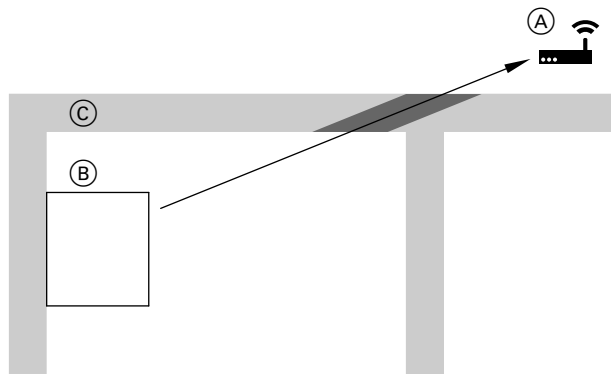

Fig. 24

- Ⓐ WiFi router
- Ⓑ Heat generator
- Ⓒ Wall

Ideal angle of penetration

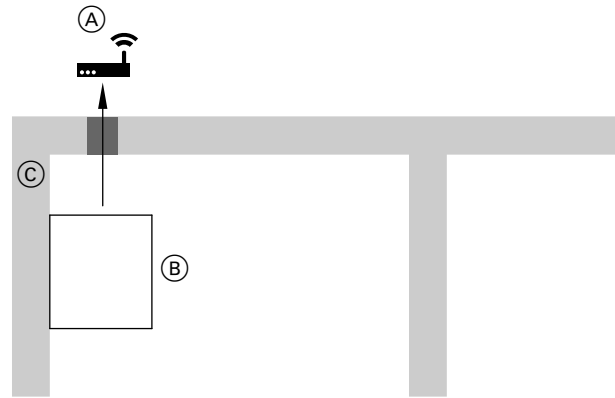

Fig. 25

- Ⓐ WiFi router
- Ⓑ Heat generator
- Ⓒ Wall

Installation

Closing the wiring chamber

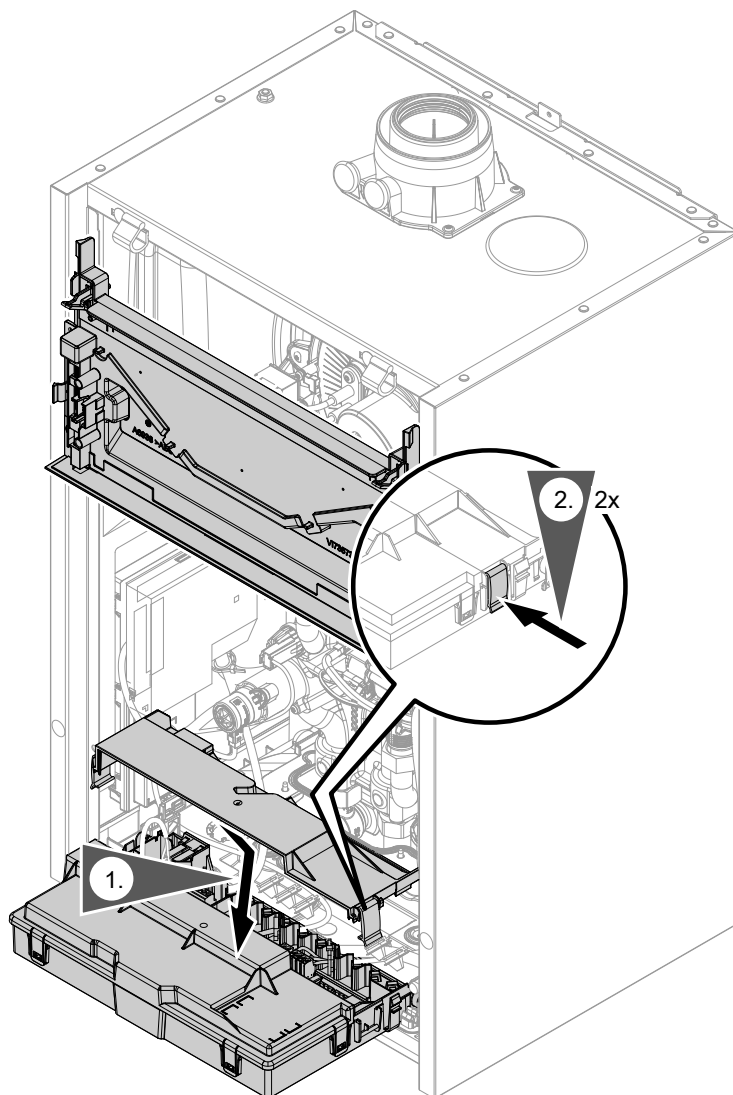
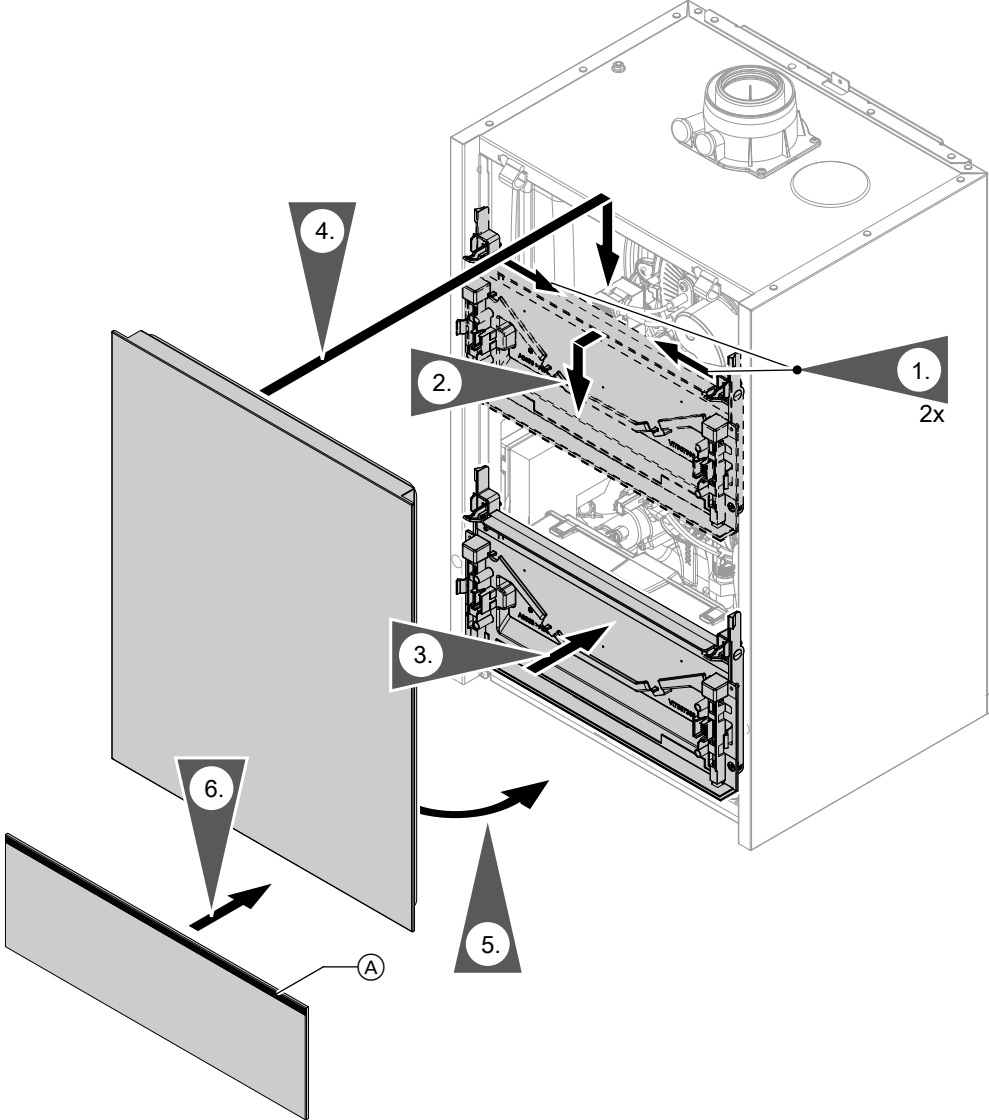

Fig. 26

Fitting the programming unit and front panel

Programming unit located at the bottom



Installation

Fig. 27

Lightguide (A) at the top

Programming unit located at the top

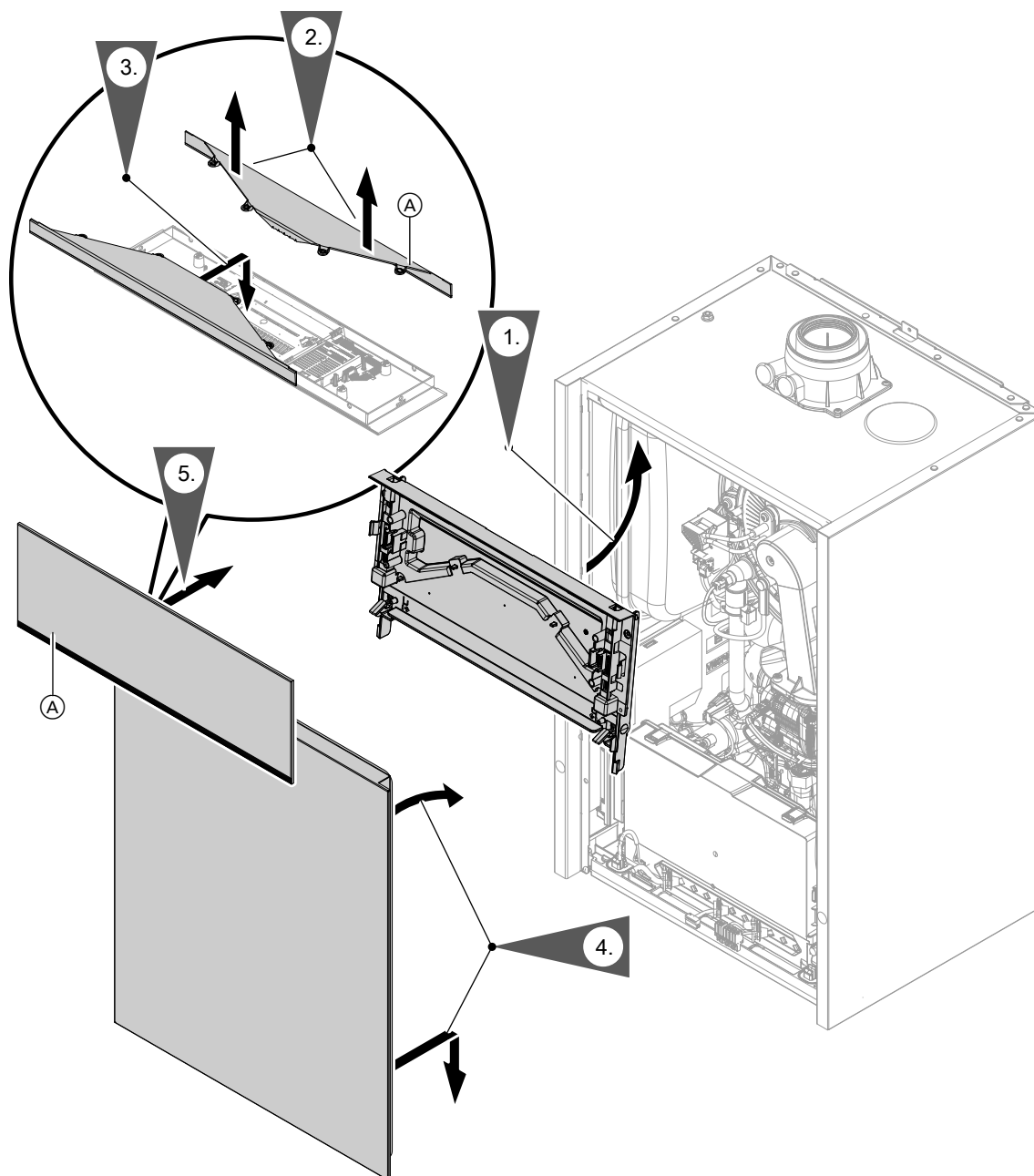

Fig. 28

1. Install the mounting panel for the programming unit at the top. See page 18.
Reconnect the plugs to the mounting panel on the right. Do not alter where and how the cable is secured (fixing point of the cable tie).
2. Pull Lightguide (A) out of all 4 detents at once and remove. As you do so, pull it upwards between 2 detents, in the middle and at the same time. Ensure that the locking tabs do not break off.
3. Turn Lightguide (A) around and clip it into place at the bottom of the programming unit.
4. Fit the front panel.
5. Fit the programming unit with Lightguide (A) at the bottom.



Steps - commissioning, inspection and maintenance

			Page
•	•	•	1. Filling the trap with water..... 36
•			2. Commissioning the system with the commissioning assistant..... 36
•	•		3. Filling the heating system..... 40
	•		4. Topping up the heating water..... 41
•	•	•	5. Checking all connections on the heating water and DHW sides for leaks..... 42
•			6. Venting the heating system..... 42
•			7. Naming the heating circuits..... 43
•			8. Entering contact details of heating contractor..... 43
•			9. Checking the gas type..... 43
•			10. Converting the gas type for operation with LPG..... 43
•	•	•	11. Removing the front panel..... 44
	•		12. Moving the programming unit to the maintenance position..... 45
•	•	•	13. Checking the static pressure and supply pressure..... 45
•			14. Function sequence and possible faults..... 47
•			15. Setting the max. heating output..... 48
•			16. Adjusting the pump rate of the integral circulation pump..... 48
•			17. Activating screed drying..... 50
•			18. Leak test on balanced flue system (annular gap check)..... 50
	•		19. Removing the burner..... 51
	•	•	20. Checking the burner gasket and burner gauze assembly..... 52
	•	•	21. Checking and adjusting the ignition and ionisation electrodes..... 53
	•	•	22. Checking the back draught safety devices..... 53
	•		23. Cleaning the heating surfaces..... 54
	•	•	24. Checking the condensate drain and cleaning the trap..... 55
	•	•	25. Installing the burner..... 56
	•	•	26. Checking the neutralising system (if installed)
	•		27. Checking the flow limiter (only for gas condensing combi boiler)..... 57
•	•	•	28. Checking the expansion vessel and system pressure..... 58
•	•	•	29. Checking the safety valve function
•	•	•	30. Checking the electrical connections for firm seating
•	•	•	31. Checking all gas equipment for leaks at operating pressure..... 58
•	•	•	32. Fitting the front panel..... 59
•	•		33. Checking the combustion quality..... 59
•	•	•	34. Checking the flue system for unrestricted flow and leaks
•	•	•	35. Checking the external LPG safety valve (if installed)
•			36. Matching the control unit to the heating system..... 60
•			37. Adjusting heating curves..... 60
	•		38. Calling up and resetting the maintenance display..... 61
•			39. Instructing the system user..... 61



Filling the trap with water

- !** **Please note**
 Only commission the appliance with a fully filled trap.
 Check that the trap has been filled with water.

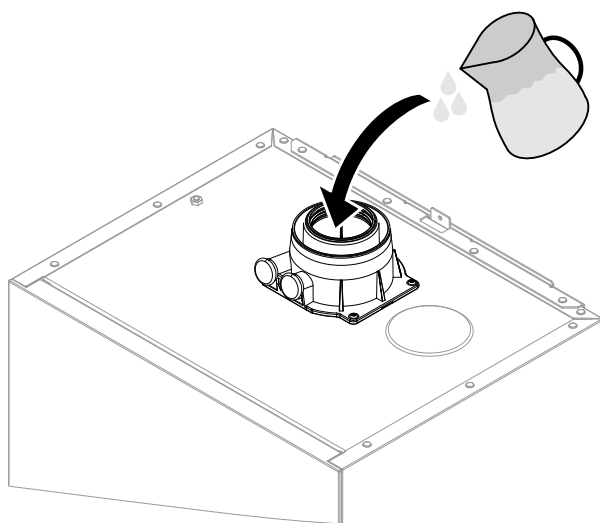

Fig. 29

Pour at least 0.3 l of water into the flue gas connection.

- !** **Please note**
 During commissioning, flue gas may escape from the condensate drain.
 Always fill the trap with water before commissioning.

Commissioning the system with the commissioning assistant

Commissioning assistant

1. Open the gas shut-off valve.
2. If the appliance has not been switched on yet: Turn on the ON/OFF switch. The commissioning assistant starts automatically.
 If the appliance has already been switched on: See chapter "Calling up the commissioning assistant at a later point".
3. For further steps, see commissioning assistant in the following overview.

Note

Once the commissioning assistant has finished, run an actuator test to check that the actuators are connected correctly and working properly.

Note

Depending on the type of heat generator, connected accessories and other settings, not all menu points will be displayed and not all functions are available. See the technical guide or hydraulic scheme browser.



Commissioning via software tool

Note

Apps for commissioning and service are available for iOS and Android devices.



The appliance automatically switches on the WiFi access point.

1. Open the gas shut-off valve.
2.  and **OK** should be pressed simultaneously for approx. 4 s.
3. Use   to select "**Connect with software tool**" and confirm with **OK**.
4. Follow the instructions in the app.



Commissioning assistant sequence	Explanations and references
Commissioning	
Language	
With programming unit	If commissioning is to be carried out at the programming unit of the heat generator.
With software tool	The appliance automatically switches on the WiFi access point. Further commissioning steps according to the instructions of the software tool used
Trade fair mode	Only for demonstration purposes. Do not select for normal heating operation.
Units of measurement	
Date and time	
Operating mode (only Vitodens 2xx)	<ul style="list-style-type: none"> ▪ Weather-compensated operation The outside temperature sensor must be connected. ▪ Continuous operation Operation with constant flow temperature ▪ Room temperature-dependent operation (available only for detached houses) A room temperature controller/room thermostat (accessories) must be connected to plug 96. Only one heating circuit without mixer in the system.
Building type	<ul style="list-style-type: none"> ▪ Detached house One shared holiday program and time program for DHW heating ▪ Apartment building (room temperature-dependent operation not available) A separate holiday program can be set for each heating circuit
Gas type	If operating with LPG, switch to " LPG "
Flue system type (only Vitodens 2xx)	<ul style="list-style-type: none"> ▪ Single connection Only one heat generator is connected to the flue system (factory setting). ▪ Multiple connections Several heat generators are connected to the flue system at positive pressure (only suitable for systems that run on natural gas).
System pressure: <ul style="list-style-type: none"> ▪ Set value ▪ Range 	<p>Select the set system pressure, e.g. 1.5 bar.</p> <p>Select the range within which the system pressure can fluctuate around the set value, e.g. +/-0.5 bar.</p> <p>If the value falls below the set range for a certain period of time (set value [1.5 bar] - range [0.5 bar] = 1.0 bar), a fault message/warning message A.11 is displayed.</p>
Filling Air vent valve	Filling: See chapters "Filling the heating system" and "Venting the heating system".
After confirmation with ✓, an automatic test of the flue gas temperature sensor is carried out. See the following chapter.	
If no further settings are to be performed, the commissioning assistant can now be closed.	
System scheme	
Heating circuit 1	Heating circuit without mixer or heating circuit without mixer with external hook-up Heating circuit without mixer with pump (without low loss header and without further heating circuits, max. 1 heating circuit in the system) for e.g. fixed value control station.
Heating circuit 2, 3 ...	Heating circuits with mixer or heating circuit with mixer with external hook-up
DHW	Settings for DHW heating according to the system components
▪ Not available	System without DHW heating





Commissioning assistant sequence	Explanations and references
<ul style="list-style-type: none"> ▪ Cylinder with one sensor ▪ Cylinder with one sensor and DHW circulation pump ▪ Loading cylinder with two sensors ▪ Loading cylinder with two sensors and DHW circulation pump 	<p>System with DHW cylinder with 1 cylinder temperature sensor</p> <p>System with DHW cylinder with 1 DHW cylinder temperature sensor and DHW circulation pump</p> <p>Gas condensing storage combi boiler or gas/solar condensing storage combi boiler with integral loading cylinder</p> <p>Gas condensing storage combi boiler or gas/solar condensing storage combi boiler with integral loading cylinder with DHW circulation pump (circulation pump not possible with Vitodens 222-W).</p>
<p>Low loss header/buffer cylinder</p>	<p>Settings for the consumer circuits according to the system components</p>
<ul style="list-style-type: none"> ▪ Not available ▪ Low loss header, heating only ▪ DHW heating upstream of low loss header ▪ DHW heating downstream of low loss header ▪ Buffer cylinder, heating only ▪ DHW heating upstream of buffer cylinder ▪ DHW heating downstream of buffer cylinder 	<p>There is no low loss header or heating water buffer cylinder in the system.</p> <p>System with low loss header, without DHW heating</p> <p>DHW heating with e.g. separate DHW cylinder connected upstream of the low loss header</p> <p>DHW heating with e.g. separate DHW cylinder connected downstream of the low loss header</p> <p>System with heating water buffer cylinder, without DHW heating</p> <p>DHW heating with e.g. separate DHW cylinder connected upstream of the heating water buffer cylinder</p> <p>DHW heating with e.g. separate DHW cylinder connected downstream of the heating water buffer cylinder</p>
<p>Solar (if installed)</p>	<p>Solar thermal system connected to heat generator via EM-S1 extension (ADIO, SDIO/SM1A electronics module)</p> <p>Setting subject to the design of the solar thermal system</p> <p> EM-S1 extension installation and service instructions</p>
<ul style="list-style-type: none"> ▪ No solar function ▪ Solar function DHW heating ▪ Solar function for central heating backup ▪ Solar function with pre-heating, 2nd cylinder ▪ Solar function with thermostat function 	<p>Only adjustable on SDIO/SM1A electronics module</p> <p>Only adjustable on SDIO/SM1A electronics module</p> <p>Only adjustable on SDIO/SM1A electronics module</p>



Commissioning assistant sequence	Explanations and references
Floating contact: Function selection plug 96	If a contact has been connected to plug 96 of the HMU heat management unit.
<ul style="list-style-type: none"> ▪ No function ▪ External demand, DHW circulation pump ▪ External demand ▪ External blocking 	<p>Pushbutton function, DHW circulation pump runs for 5 min.</p> <p>Heat generator demand with adjustable set flow temperature (parameter 528.0) and set primary pump speed (parameter 1100.2)</p>
EM-EA1 (DIO): Function selection	If an EM-EA1 extension (DIO electronics module) is connected as a function extension.
Functions	Selection of the connected function according to the table in the EM-EA1 extension installation instructions.
Remote control units	
	Set the type of remote control and subscriber no. as assignment to the respective heating circuit. Up to 3 heating circuits can be assigned to one remote control unit. It is not possible for several remote controls to act on one heating circuit.
Maintenance	
Interval in burner hours run until next maintenance	Interval adjustable in steps of 100 h.
Interval until next maintenance	Interval adjustable to 3, 6, 12, 18 or 24 months.

Automatic flue gas temperature sensor check

The display shows: **"Testing, flue gas temperature sensor"** and **"Enabled"**.

If the flue gas temperature sensor is not positioned correctly, fault message F.416 appears.

For further details regarding the flue gas temperature sensor test, see "Repairs".

Note

If fault message F.416 continues to be displayed although the flue gas temperature sensor is correctly positioned: Initial commissioning may result in burner faults e.g. caused by air in the gas line. Eliminate the fault and reset the appliance.

Note

The burner remains locked out until the test has been passed.

When the fault has been remedied, turn the ON/OFF switch off and back on again.

Confirm the commissioning assistant with ✓.

Switching WiFi ON/OFF

The appliance is equipped with an integrated WiFi communication module with extended type plate.

The internal communication module supports commissioning, maintenance and servicing with "ViGuide" online/the "ViGuide" app as well as operation via the "ViCare" app.

The access details required for establishing a connection are recorded in the form of an access code with **"WiFi symbol"**. Three copies of this code are located on the front of the programming unit.

Remove the access code label and for commissioning, affix one label to the space marked out on the type plate.

Switch on the WiFi connection and establish a connection to the router; see also page 31.

Activating the internet connection:



Operating instructions

Affix a further label here so you can find it again for use at a later time:



Fig. 30

Affix a label in the operating instructions.

Calling up the commissioning assistant at a later point

If you need to continue commissioning later, the commissioning assistant can be reactivated at any time.

Tap the following buttons:

- 1.
2. "Service"
3. Enter password "viservice".
4. Confirm with
5. "Commissioning"

Filling the heating system

Fill water

As a heat transfer medium for DHW heating, the heating water must meet fluid category ≤ 3 . This requirement is met if water of potable quality is used as heating water. For example, if additives are used, the additive manufacturer must specify which category the treated heating water comes under.

! Please note

- Unsuitable fill water increases the level of deposits and corrosion and may lead to appliance damage.
 - Flush the heating system thoroughly before filling.
 - Only use fill water of potable water quality.
 - Special antifreeze suitable for heating systems can be added to the fill water. The antifreeze manufacturer must verify its suitability.
 - Fill and top-up water with a water hardness above 300 ppm must be softened, e.g. with a small softening system for heating water.

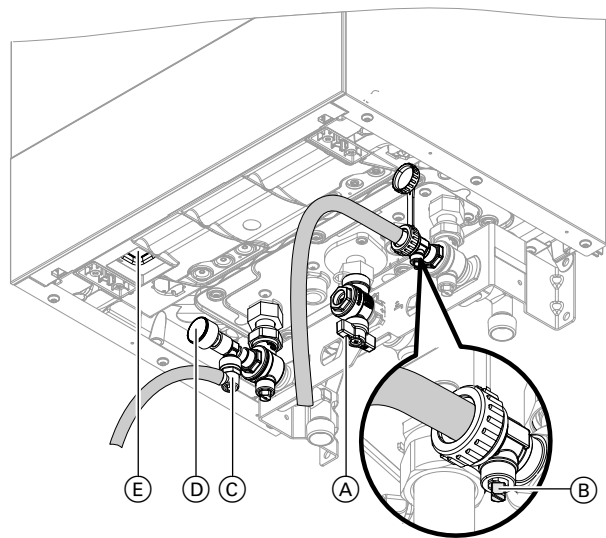

Fig. 31

(E) ON/OFF switch

1. Check the pre-charge pressure of the expansion vessel.
2. Close gas shut-off valve (A).
3. Activate the filling function (see commissioning assistant or following chapter).
4. Fill the heating system at boiler drain & fill valve (B) in the heating return (on the connection set or on site). Minimum system pressure > 1.0 bar (0.1 MPa). Check the system pressure at pressure gauge (D). The indicator must be in the green band. If necessary, open the on-site air vent valves.

Note

Ensure that the safety valve does not respond when you are filling the system. If the flow rate through the safety valve becomes too high, water may enter the combustion chamber.



Filling the heating system (cont.)

5. Fit hose to air vent valve (C). Route the hose into a suitable container or drain outlet.
6. Close the shut-off valves on the heating water side.
7. Open air vent valve (C) and fill valve (B) in the heating return. Vent (flush) under mains pressure until no more air noise is audible.
8. Close air vent valve (C) and boiler drain & fill valve (B).
Check the system pressure at pressure gauge (D). The indicator must be in the green band.
9. Open the shut-off valves on the heating water side.

Activating the filling function

Tap the following buttons:

- 1.
2. "Service"
3. Enter password "viservice".
4. Use to confirm.
5. "Service functions"
6. "Filling"
7. Activate the filling function with .
The display shows the system pressure.
The filling function ends automatically after 20 min or when you tap .



Topping up the heating water

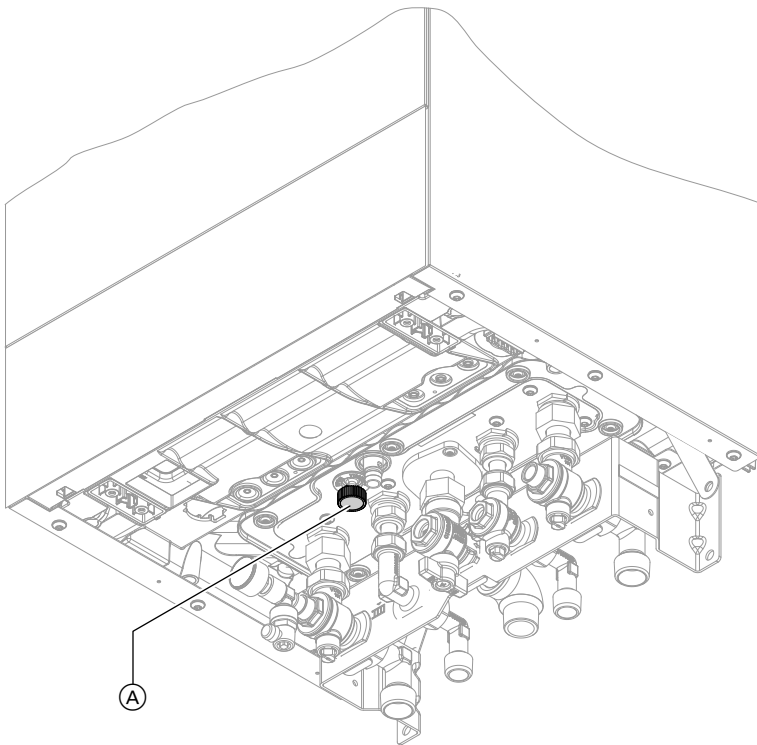

Fig. 32

If required, top up the heating water at top-up valve (A).



Checking all connections on the heating water and DHW sides for leaks



Danger

There is a risk of electric shock from escaping heating water or DHW.
When commissioning and after carrying out maintenance work, check all water side connections for leaks.



Please note

Leaking hydraulic connections lead to appliance damage.

- Check the internal and on-site hydraulic connections for leaks.
- In the event of leaks, switch off the appliance immediately. Drain the heating water. Check the seating of seal rings. **Always** replace displaced seal rings.



Venting the heating system

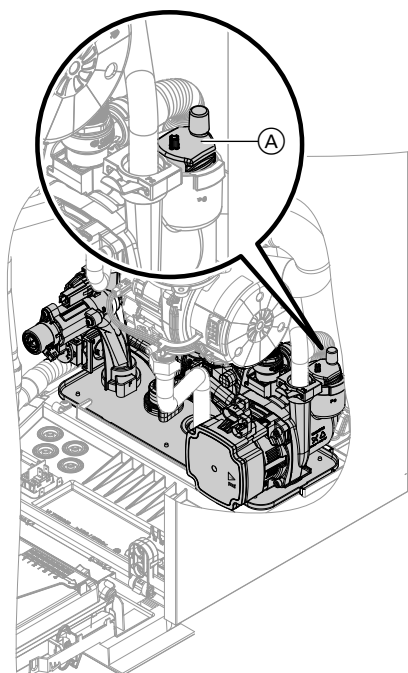

Fig. 33

1. Check whether the air vent screw in quick-action air vent valve (A) of the heating circuit pump is open.
2. Close the gas shut-off valve and switch the appliance ON.
3. Activate the venting program (see commissioning assistant or following chapter).
4. Adjust the system pressure.
The display shows the system pressure.
5. Disconnect the supply hose from the boiler drain & fill valve.
6. Open the gas shut-off valve.

Note

Leave the quick-action air vent valve open once the venting program has finished.

Activating the venting function

Tap the following buttons:

1. ☰

2. "Service"

3. Enter password "viservice".

4. Use ✓ to confirm.

5. "Service functions"

6. "Air vent valve"



Venting the heating system (cont.)

7. Activate the venting function with ✓.
The display shows the system pressure.
The venting function ends automatically after 20 min or when you tap ✓.



Naming the heating circuits

In the delivered condition, the heating circuits are designated "Heating circuit 1", "Heating circuit 2", "Heating circuit 3" and "Heating circuit 4".

If the system user prefers, the heating circuits can be renamed to suit the specific system.

To enter names for heating circuits:



Operating instructions



Entering contact details of heating contractor

The system operator can call up contact details when required and notify the heating contractor.

1. ☰
2. Select "**Information**".
3. Select "**Service contact details**".
4. Fill in the fields and confirm each with ✓.



Checking the gas type

The boiler is equipped with an electronic combustion controller that adjusts the burner for optimum combustion in accordance with the prevailing gas quality.

- For operation with natural gas, no adjustment is therefore required across the entire Wobbe index range. The boiler can be operated within the Wobbe index range 9.5 to 15.2 kWh/m³ (34.2 to 54.7 MJ/m³).
- For operation with LPG, the gas type needs to be changed on the control unit (see following chapter).

1. Determine the gas type and Wobbe index by asking your local gas supply utility or LPG supplier.
2. Record the gas type in the service report.



Converting the gas type for operation with LPG

1. To change the gas type on the control unit, see "Commissioning the system with the commissioning assistant"
2. Affix label "G31" (supplied with the technical documentation) adjacent to the type plate on the cover panel.

Note

Mechanical conversion on the gas solenoid valve is not possible.



Removing the front panel

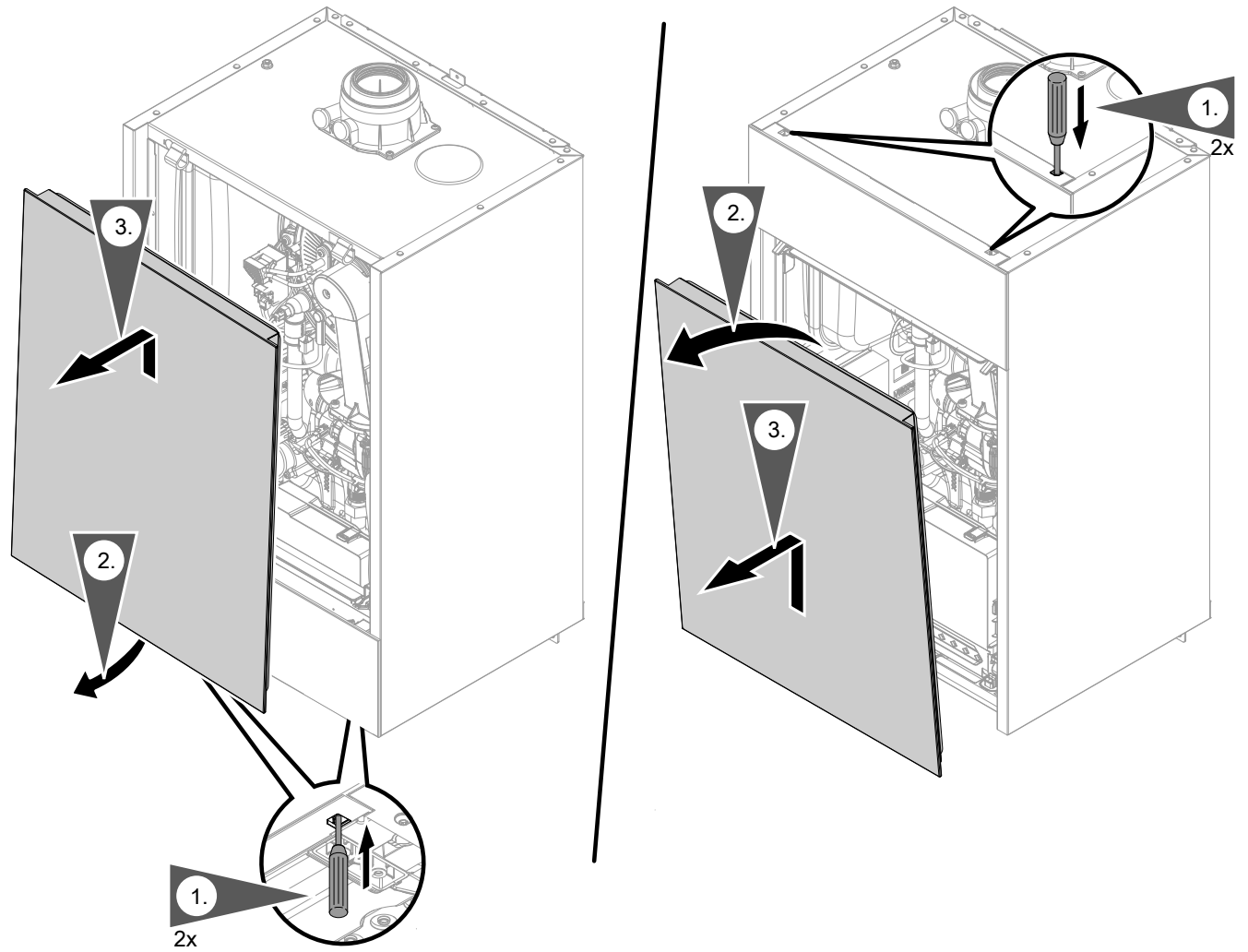

Fig. 34



Moving the programming unit to the maintenance position

To facilitate certain maintenance tasks, move the programming unit up or down, depending where it is located.

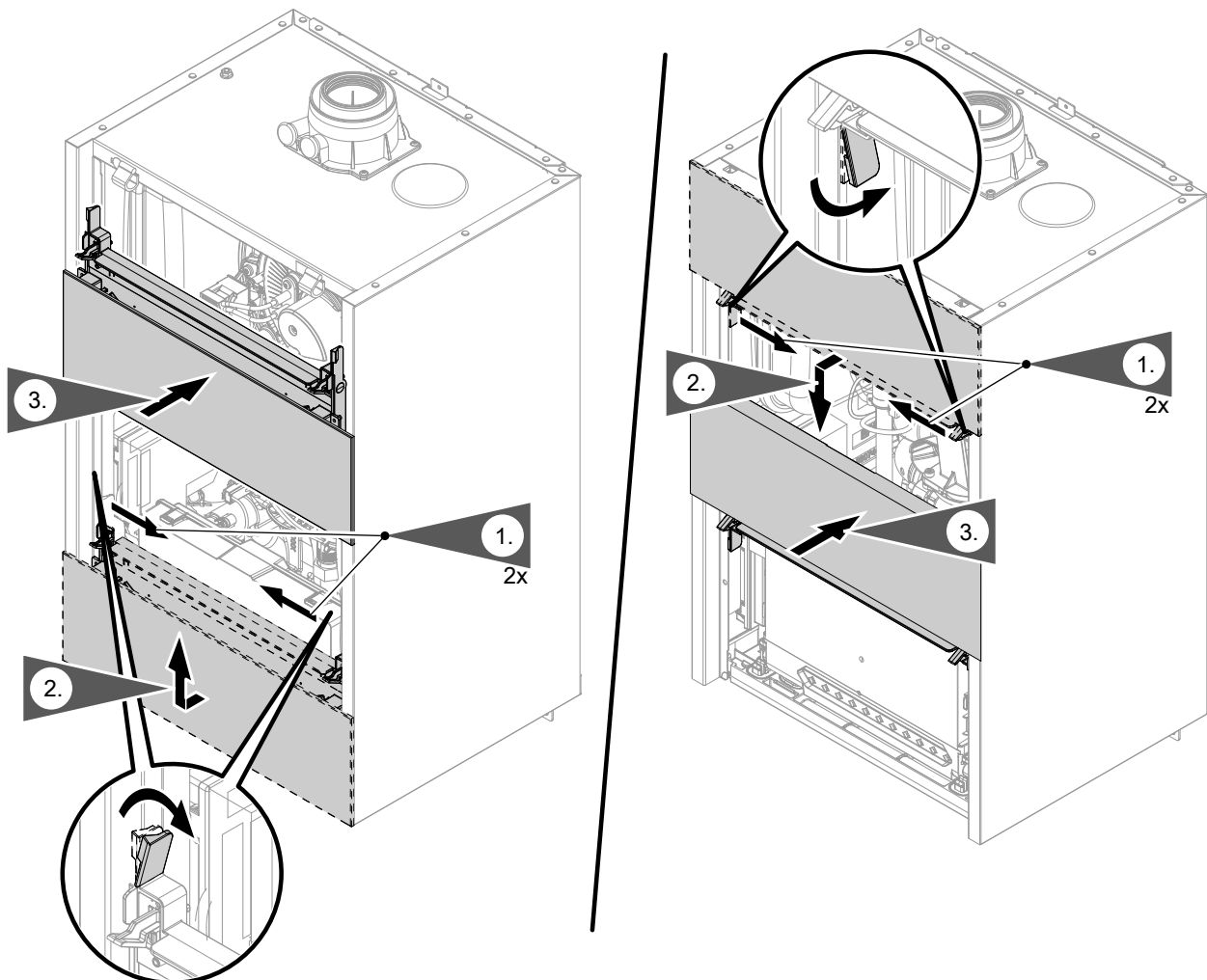

Fig. 35

Do not disconnect the plug from the mounting panel.
Do not alter where and how the cable is secured (fixing point of the cable tie).



Checking the static pressure and supply pressure



Danger
CO formation as a result of incorrect burner adjustment can have serious health implications. Always carry out a CO test before and after work on gas appliances.

Operation with LPG

Purge the LPG tank twice on commissioning/replacement. Vent the tank and gas connection line thoroughly after purging.

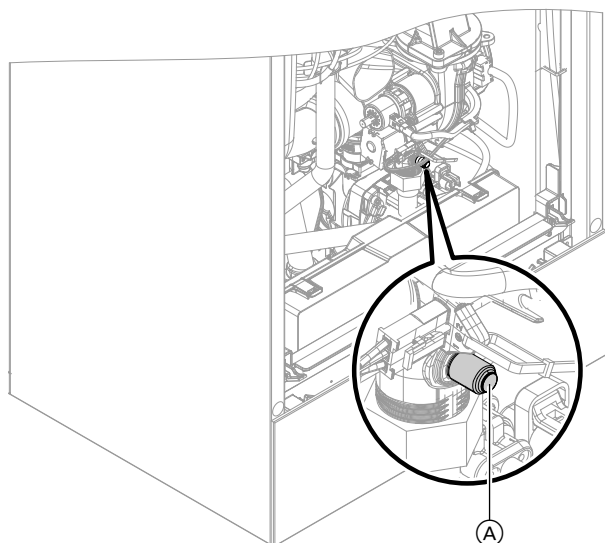

Fig. 36

1. Turn off the ON/OFF switch.
2. Close the gas shut-off valve.
3. Undo screw (A) inside test connector on the gas train, but do not remove it. Connect the pressure gauge.
4. Open the gas shut-off valve.
5. Measure the static pressure and record it in the report:
max. 57.5 mbar (5.75 kPa).
6. Turn on the ON/OFF switch and start the boiler.

Note

During commissioning, the appliance can enter a fault state if there are airlocks in the gas line. Reset the appliance after approx. 5 s (see operating instructions).

7. Check the supply (flow) pressure. For set values, see the following table.

Note

Use a suitable measuring device with a resolution of at least 0.1 mbar (0.01 kPa) to check the supply pressure.

8. Record the actual value in the report. Implement measures as indicated in the table below.
9. Shut down the boiler. Close the gas shut-off valve. Remove the pressure gauge. Close test connector (A) with the screw.
10. Open the gas shut-off valve and start the appliance.



Danger

Gas escaping from the test connector leads to a risk of explosion. Check gas tightness at test connector (A).

11. Fit front panel (see installation sequence).

Supply pressure (flow pressure)		Measures
For natural gas	For LPG	
< 13 mbar (1.3 kPa)	< 25 mbar (2.5 kPa)	Do not start the boiler. Notify the gas supply utility or LPG supplier.
13 to 25 mbar (1.3 to 2.5 kPa)	25 to 57.5 mbar (2.5 to 5.75 kPa)	Start the boiler.
> 25 mbar (2.5 kPa)	> 57.5 mbar (5.75 kPa)	Install a separate gas pressure governor upstream of the system. Set the pre-charge pressure to 20 mbar (2.0 kPa) for natural gas and 50 mbar (5.0 kPa) for LPG. Notify the gas supply utility or LPG supplier.



Function sequence and possible faults

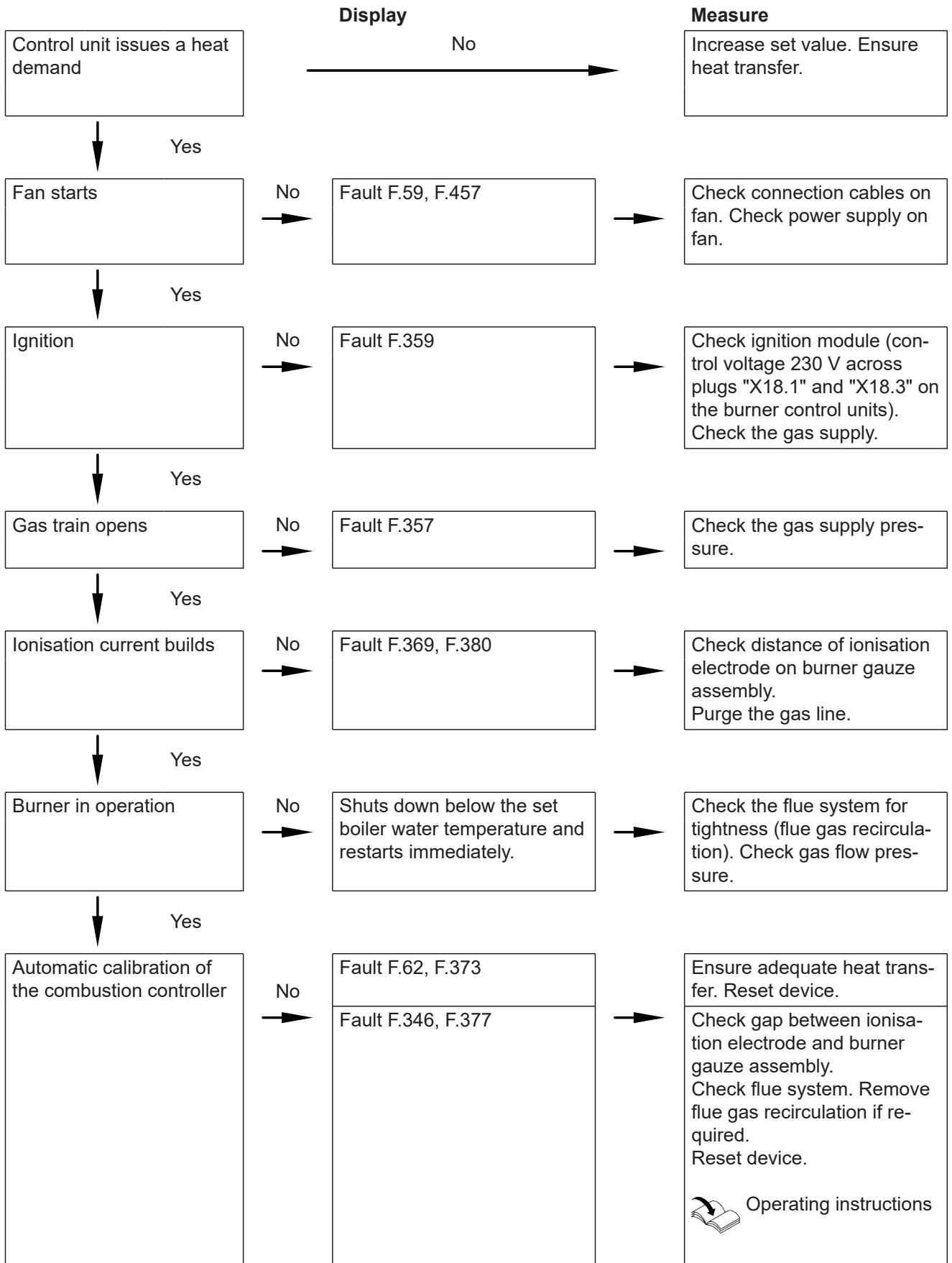

For further details regarding faults, see page "Troubleshooting".



Setting the max. heating output

A limit can be set on the maximum heating output for **heating mode**. The limit is set via the modulation range.

Note

The flow rate must be checked before the max. heating output can be adjusted. Ensure adequate heat transfer.

1. Tap .
2. Select **"Service"**.
3. Enter password **"viservice"**.
4. Use to confirm.
5. Select **"System configuration"**.
6. Select **"Boiler"**.
7. Parameter **596.0 "Maximum heating output"**
8. Check that a sufficient flow rate is ensured. If necessary, increase the heat transfer. Confirm the message with .
9. .
10. Set required value as a % of the rated heating output and confirm with . Factory setting 100 %.
11. End service functions.



Adjusting the pump rate of the integral circulation pump

Operation of the integral circulation pump as heating circuit pump for heating circuit 1

The pump speed and consequently the pump rate are controlled subject to the outside temperature and the switching times for heating mode or reduced mode. The minimum and maximum speeds for heating mode can be matched to the existing heating system at the control unit.

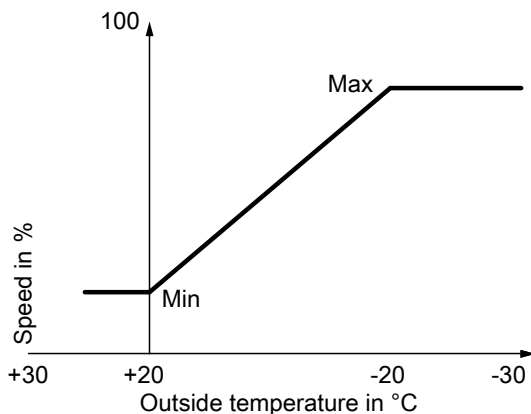

Fig. 37

Setting (%) in Heating circuit 1 group:

- Min. speed: Parameter 1102.0
- Max. speed: Parameter 1102.1



Adjusting the pump rate of the integral... (cont.)

- In the delivered condition, the minimum pump rate and the maximum pump rate are set to the following values:

Note

The minimum speed of 60 % is not undershot, in order to ensure the required flow rate via the internal overflow valve. Having the minimum pump rate set to 40 % ensures that the pump works more energy efficiently in weather-compensated mode.

Rated heating output in kW	Speed settings in the delivered condition in %	
	Min. pump rate	Max. pump rate
11	40	60
19	40	65
25	40	75
32	40	100

- In the following system conditions, the internal circulation pump is operated at a constant speed:
 - Low loss header or heating water buffer cylinder and heating circuits with mixer
 - Continuous operation
 Speed setting (%): Parameter 1100.2 in the Boiler group

Residual head of integral circulation pump

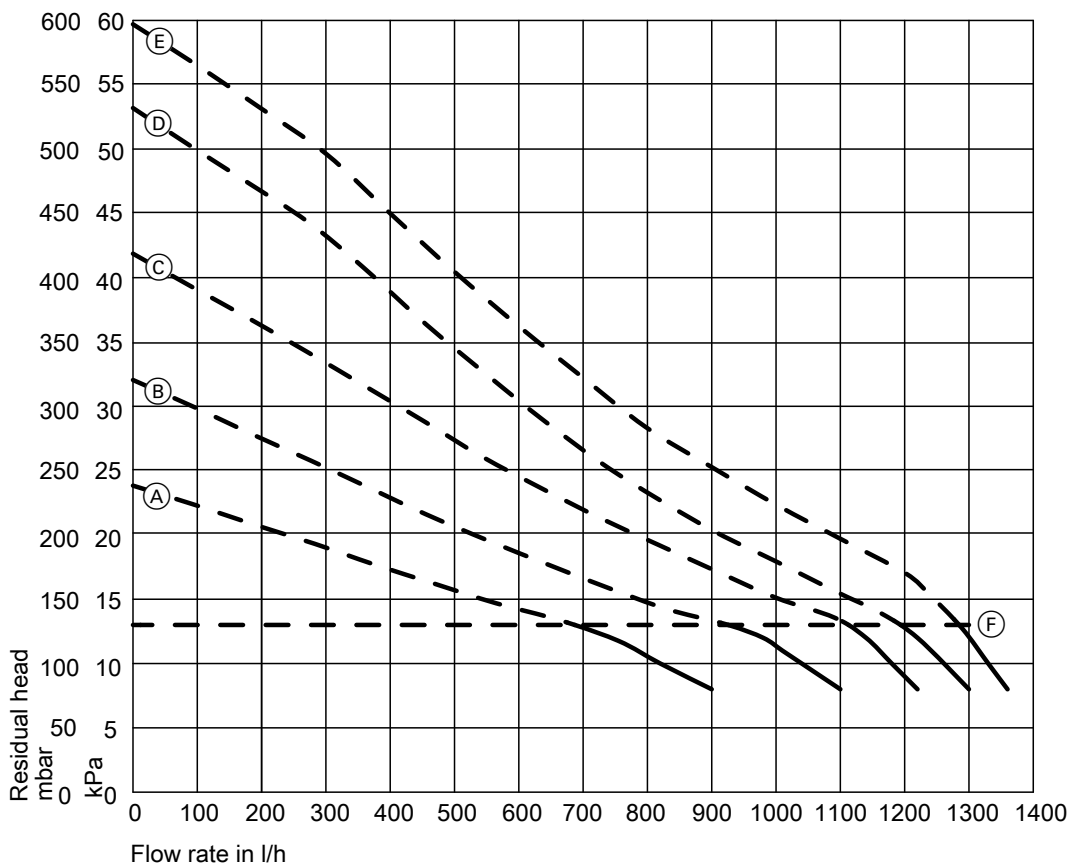

Fig. 38

Ⓕ Upper operational limit (integral bypass opens)





Adjusting the pump rate of the integral... (cont.)

Curve	Pump rate of circulation pump
(A)	60 %
(B)	70 %
(C)	80 %
(D)	90 %
(E)	100 %



Activating screed drying

Screed drying

6 different temperature profiles can be set for screed drying:

Preset temperature profiles can be adjusted via parameter **897.0 "Screed drying"** in the General group.

For further details, see "Function description".

Note

Screed drying applies to all connected heating circuits simultaneously.

With a combi boiler, DHW heating is not possible during screed drying. With a system boiler or storage combi boiler, after 30 minutes DHW heating is suspended for an hour (parameter 1087.1) in order to run the screed drying program.



Leak test on balanced flue system (annular gap check)

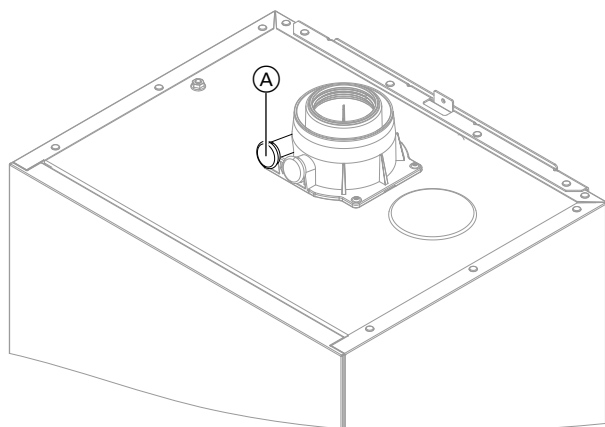

Fig. 39

(A) Combustion air aperture

For balanced flue systems tested together with the heat generator, there is no requirement for a tightness test (overpressure test) during commissioning by the flue gas inspector.

In this case, we recommend that a simple tightness test is carried out during system commissioning. For this, check the CO₂ or O₂ concentration in the combustion air at the annular gap of the balanced flue pipe. If the CO₂ concentration is less than 0.2 % or the O₂ concentration is greater than 20.6 %, the flue pipe is deemed to be sufficiently gas-tight.

If actual CO₂ values are greater or O₂ values are lower, then pressure test the flue pipe with a static pressure of 200 Pa.



Please note

If the test port is not sealed, combustion air is drawn in from the room.

After the tightness test, re-seal the test port with the plug.



Removing the burner

Note

If the programming unit is located at the top: Move the programming unit down into the maintenance position. See page 45.

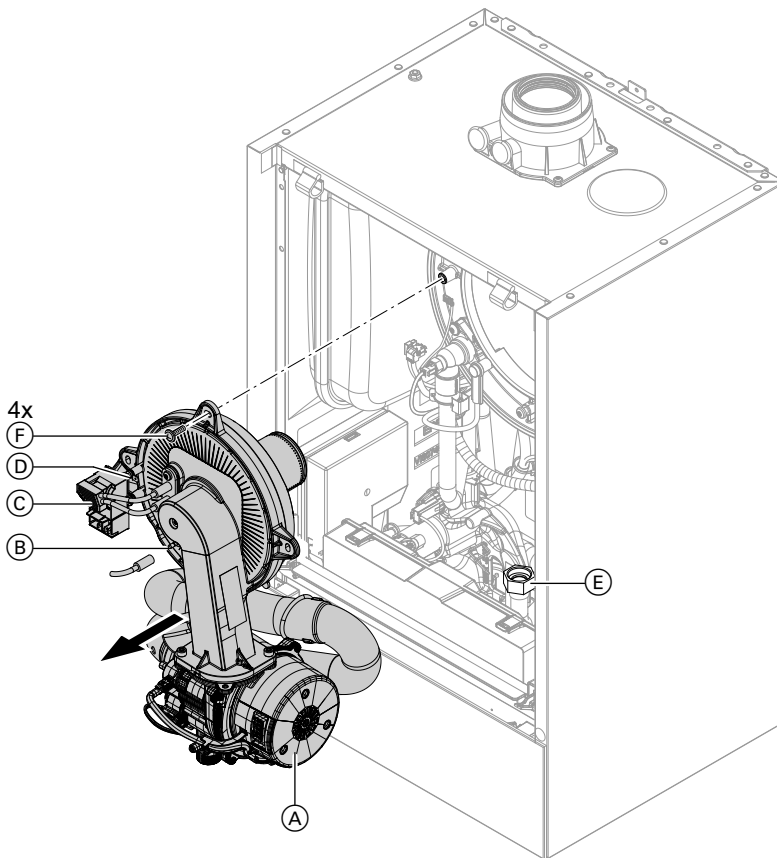

Fig. 40

1. Turn off the ON/OFF switch.
2. Close the gas shut-off valve and safeguard against reopening.
3. Disconnect cables and leads from:
 - Fan motor (A) (2 plugs)
 - Ionisation electrode (B)
 - Ignition unit (C)
 - Earth (D)
4. Undo gas supply pipe fitting (E).
5. Undo 4 screws (F) and remove the burner.

Note

Cover gas connection (E) so that no small parts can fall into it.

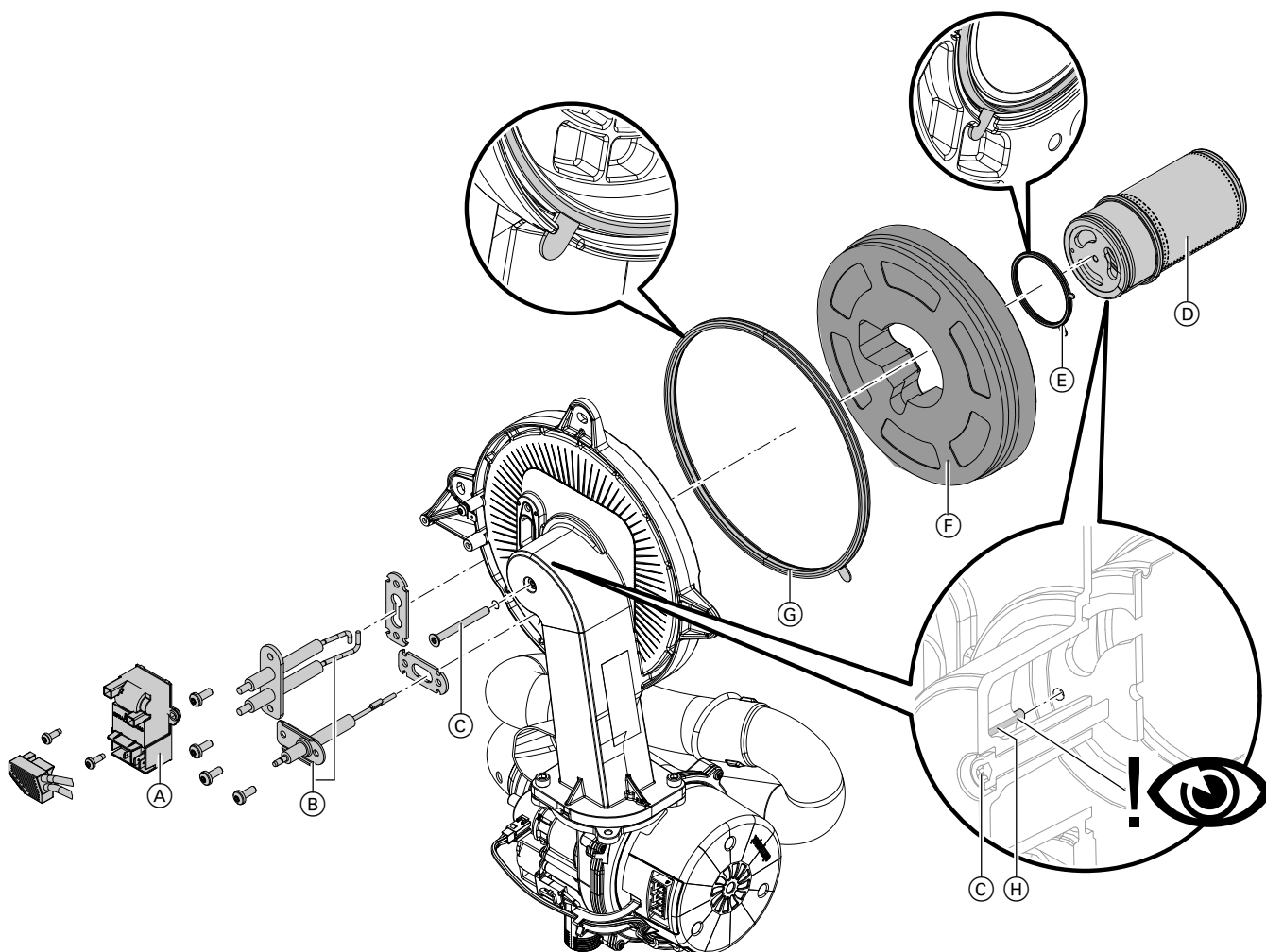

Fig. 41

Check burner gauze assembly (D), electrodes (B), thermal insulation ring (F) and gasket (G) for damage. Only remove and replace components if they are damaged or worn.

Note

If replacing the burner gauze assembly, also replace the gauze assembly gasket and the fixing screw.

1. Disconnect plug with ignition electrode leads from ignition unit (A).
2. Remove electrodes (B).
3. Undo Torx screw (C). Hold onto burner gauze assembly (D) when undoing the screw.
4. Remove burner gauze assembly (D) with gasket (E) and thermal insulation ring (F). Check components for damage.
5. Install new burner gasket (G). Observe correct installation position. Align the tab as per the diagram.

6. Insert thermal insulation ring (F) and burner gauze assembly (D) with gasket (E). Observe correct installation position. Align the tab as per the diagram.

7. Align the hole in burner gauze assembly (D) with burner door pin (H).



Please note

Incorrect positioning of the burner gauze assembly on the burner door will cause damage to the burner door. Insert the burner door pin into the hole in the burner gauze assembly.

Secure burner gauze assembly (D) and gasket (E) with Torx screw (C).

Tighten screws as tightly as necessary and ensure that the components are undamaged and are functioning correctly throughout service life. Observe torque settings if a torque wrench is available.

Torque: 3.0 Nm.

8. Check thermal insulation ring (F) for firm seating.



Checking the burner gasket and burner gauze... (cont.)

9. Fit electrodes (B). Check clearances, see following chapter.
Tighten screws as tightly as necessary and ensure that the components are undamaged and are functioning correctly throughout service life.
Observe torque settings if a torque wrench is available.
Torque: 4.5 Nm.



Checking and adjusting the ignition and ionisation electrodes

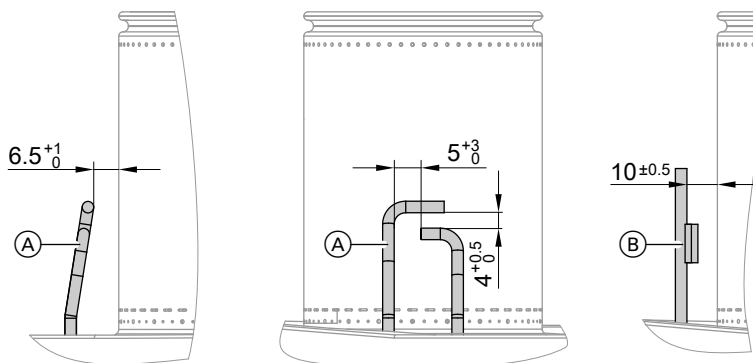

Fig. 42

- (A) Ignition electrodes
(B) Ionisation electrode

1. Check the electrodes for wear and contamination.
2. Clean the electrodes with a small brush (not a wire brush) or sandpaper.
3. Check the electrode gaps. If the gaps are not as specified or the electrodes are damaged, replace the electrodes and gaskets and adjust them as required.
Tighten screws as tightly as necessary and ensure that the components are undamaged and are functioning correctly throughout service life.
Observe torque settings if a torque wrench is available.
Tighten the electrode fixing screws to a torque of 4.5 Nm.



Checking the back draught safety devices

Only for multiple connections to a flue system or multi boiler systems with a flue gas cascade.



Checking the back draught safety devices (cont.)

Back draught safety device in the mixing shaft of the burner

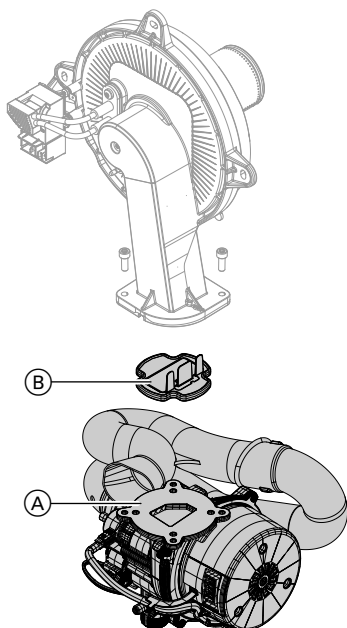

Fig. 43

1. Undo 2 screws and remove fan (A).
2. Remove back draught safety device (B).
3. Check the damper and gasket for dirt and damage. Replace if necessary.
4. Refit back draught safety device (B).

Note

Observe correct installation position.

5. Refit fan (A) and secure with 2 screws. Tighten screws as tightly as necessary and ensure that the components are undamaged and are functioning correctly throughout service life. Observe torque settings if a torque wrench is available.
Torque: 4.0 Nm

Back draught safety device in the flue gas connection

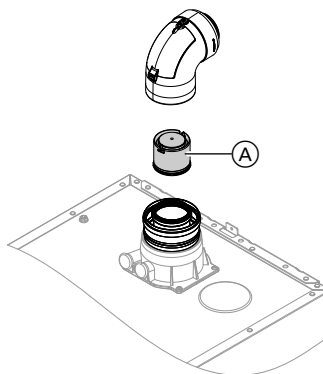

Fig. 44

1. Remove the balanced flue system.

Note

If the balanced flue system cannot be removed, clean and check the back draught safety device via the inspection cover.

2. Check back draught safety device (A) for dirt, ease of movement and function.
3. Refit the balanced flue system.
4. Pour a small amount of water through the inspection port to ensure the back draught safety device is working.



Cleaning the heating surfaces



Please note

Scratches to the surfaces of the heat exchanger that come into contact with hot gas can result in corrosion damage. Brushing can cause deposits to become lodged in the gaps between the coils. **Never use brushes to clean the heating surfaces.**



Please note

Prevent damage due to cleaning water. Cover electronic components with suitable watertight material.

Note

Discolouration on the heat exchanger surface is a normal sign of use. It has no bearing on the function and service life of the heat exchanger. The use of chemical cleaning agents is not required.



Cleaning the heating surfaces (cont.)

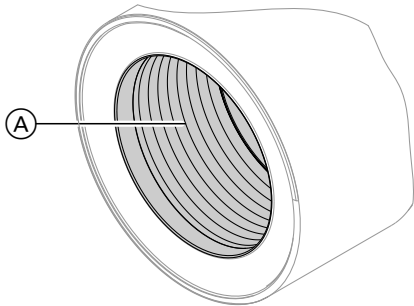

Fig. 45

1. Use a vacuum cleaner to remove combustion residues from heating surface (A) of the heat exchanger.
2. Flush heating surface (A) with water.
3. Check condensate drain. Clean the trap: See the following chapter.
4. Check the thermal insulation mat (if installed) in the heat exchanger for damage, replace if necessary.



Checking the condensate drain and cleaning the trap

! **Please note**
Prevent damage due to condensate.
Cover electronic components with suitable watertight material.

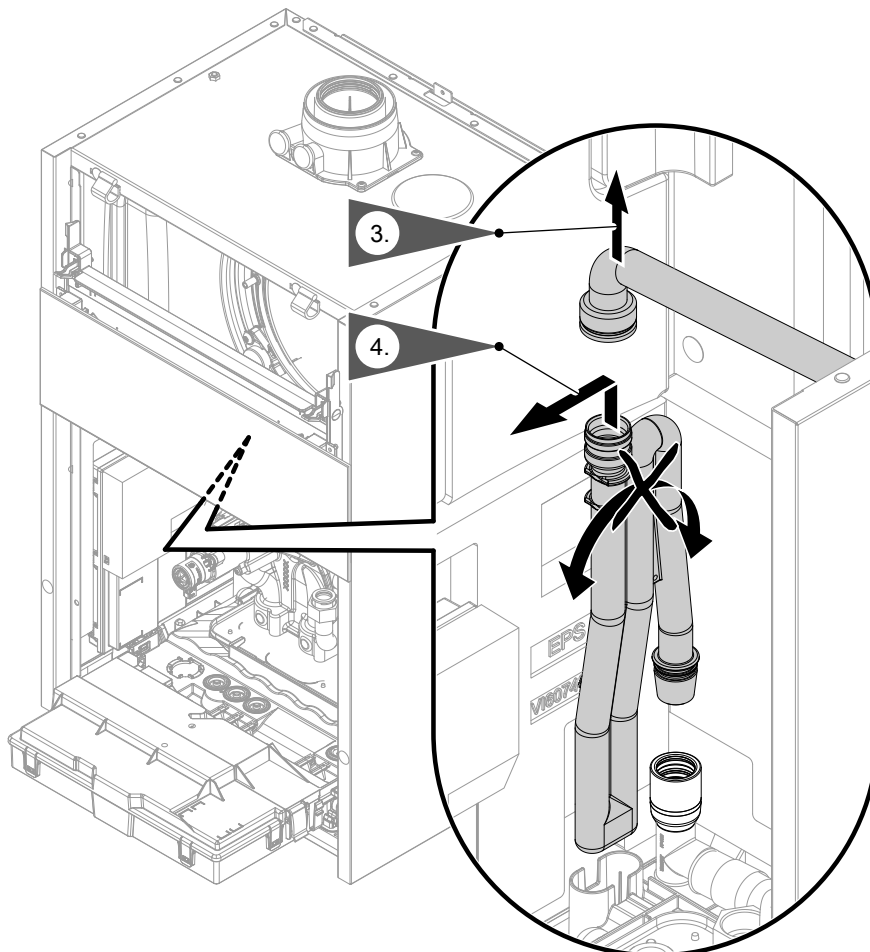

Fig. 46

1. Move the bracket together with the programming unit upwards. See "Moving the programming unit to the maintenance position".
2. Pivot the HMU heat management unit forwards.
3. Remove the black supply hose.
4. Pull trap upwards out of the drain hose.
5. Hold trap as straight as possible and remove. Ensure that no condensate runs out.
6. Clean the trap.





Checking the condensate drain and cleaning the... (cont.)

7. Fill the trap with water and refit it on the drain hose.



Please note

If the trap is not filled with water, flue gas can escape.
Only start the appliance when the trap has been filled.
Check that the trap is seated correctly.

8. Refit supply hose.

Multi boiler system:

Clean the trap in the flue gas collector as well.

9.



Danger

Risk of electric shock from escaping condensate.
Check the connections for leaks and check that the trap is seated correctly.

Note

Route the drain hose without any bends and with a constant fall.



Installing the burner

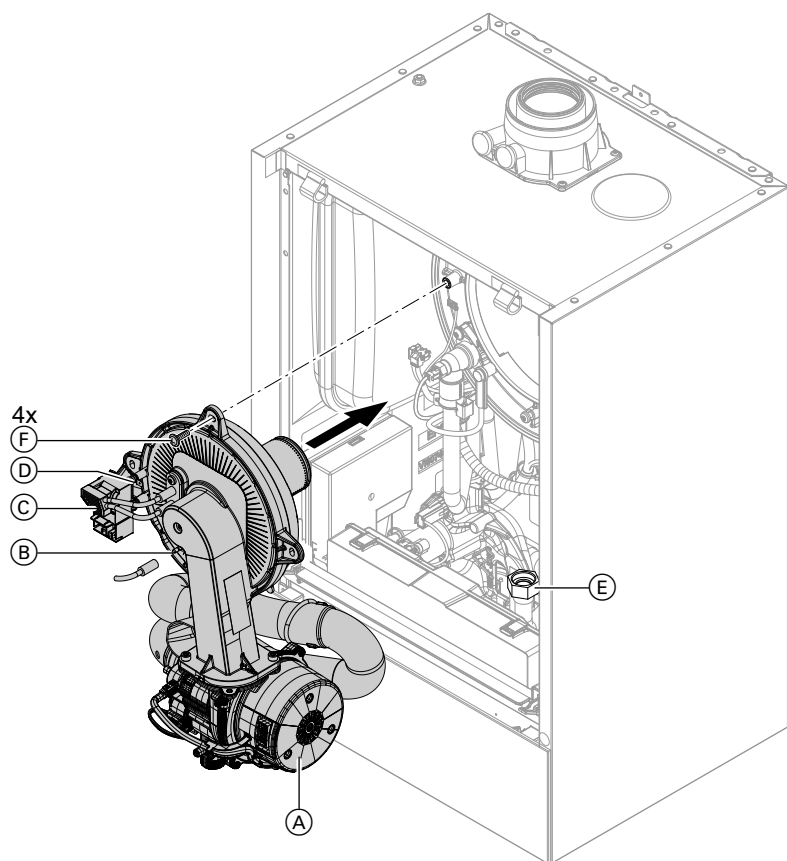

Fig. 47

1. If necessary, move the programming unit.

2. Insert the burner. Tighten screws (F) diagonally. Tighten screws as tightly as necessary and ensure that the components are undamaged and are functioning correctly throughout service life. Observe torque settings if a torque wrench is available.
Torque: 6.5 Nm

3. Fit gas supply pipe (E) with a new gasket.
Torque: 30 Nm

4. Check the gas connections for leaks.









Danger

Escaping gas leads to a risk of explosion. Check all fittings for gas tightness. In the case of wall mounted appliances, also check the gas shut-off valve fitting on the underside.

   **Installing the burner (cont.)**

5. Connect the cables/leads:
 - Fan motor (A) (2 plugs)
 - Ionisation electrode (B)
 - Ignition unit (C)
 - Earth (D)

   **Checking the neutralising system (if installed)**

   **Checking the flow limiter (only for gas condensing combi boiler)**

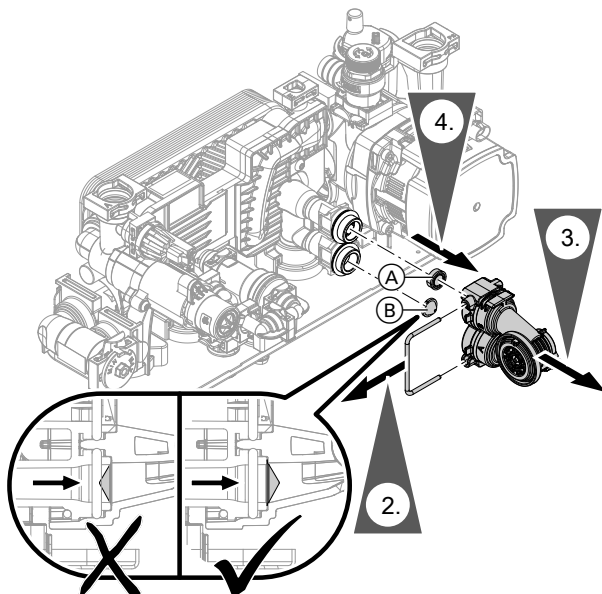

Fig. 48

1. Drain the boiler on the DHW side.
2. Remove the spring clip.
3. Remove the DHW flow sensor.
4. Check flow limiter (A) and filter strainer (B). Replace if scaled or damaged.

Note

Install filter strainer (B) with the cone pointing in the direction of flow.

Note

Filter strainer (B) is installed in appliances only as shown in the figure on the right:

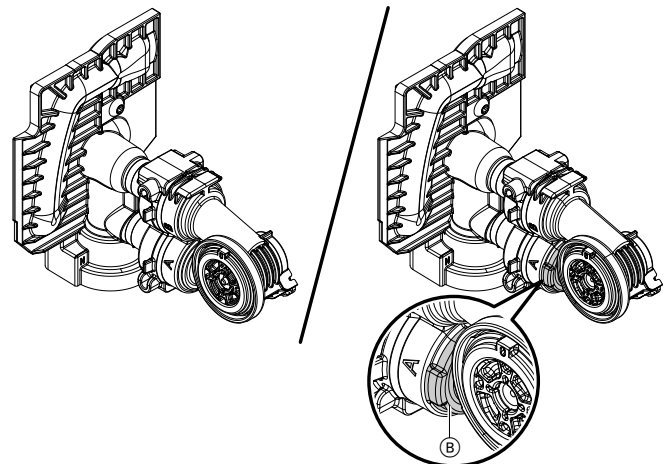

Fig. 49

5. Mount DHW flow sensor with new gaskets.



Danger

Risk of electric shock from escaping heating water or DHW.

Check all water side connections for tightness.



Checking the flow limiter (only for gas... (cont.))

Flow limiter

Appliance type	Flow rate l/min	Colour
B2KF-19	12	Red
B2KF-25	14	Pink
B2KF-32	16	Blue



Checking the expansion vessel and system pressure

Note

The burner control unit can be removed to allow better access to the test connector:

- Pull the burner control unit to the right at the top until the hook and loop fastening comes apart.
- Undo the catch and remove the burner control unit from the retainer by lifting it upwards.

Note

The expansion vessel can lose some of its charge pressure over time. If the boiler heats up, the pressure rises to 2 or 3 bar (0.2 or 0.3 MPa). The safety valve may also respond and discharge the excess pressure. Therefore check the expansion vessel pre-charge pressure annually.

Check whether the installed expansion vessel is adequate for the system water volume. Carry out this test on a cold system.

1. Drain the system until "0" is shown on the pressure indicator.
2. If the pre-charge pressure of the expansion vessel is lower than the static system pressure: Top up with nitrogen at the valve of the diaphragm expansion vessel until the pre-charge pressure is 0.1 to 0.2 bar (10 to 20 kPa) higher than the static system pressure.

3. Top up with water until the charge pressure of the cooled system is at least 1.0 bar (0.1 MPa), and is 0.1 to 0.2 bar (10 to 20 kPa) higher than the pre-charge pressure of the expansion vessel. Permiss. operating pressure: 3 bar (0.3 MPa)

Note

The expansion vessel is supplied from the factory with a pre-charge pressure of 0.7 bar (70 kPa). Do not allow the pre-charge pressure to fall below this value (boiling noises). This also applies to single floor heating systems or attic heating centres (no static pressure). Top up with water until the charge pressure is 0.1 to 0.2 bar (10 to 20 kPa) above the pre-charge pressure.



Checking the safety valve function



Checking the electrical connections for firm seating



Checking all gas equipment for leaks at operating pressure



Danger

Escaping gas leads to a risk of explosion. Check gas equipment (including inside the appliance) for leaks.



Checking all gas equipment for leaks at... (cont.)

Note

Only use suitable and approved leak detection agents (EN 14291) and devices for the tightness test. Leak detection agents with unsuitable constituents (e.g. nitrides, sulphides) can cause material damage. Remove residues of the leak detection agent after testing.



Fitting the front panel

See page 33.



Checking the combustion quality

The electronic combustion controller automatically ensures optimum combustion quality. During commissioning/maintenance, only the combustion values need to be checked. To do this, test the CO content and CO₂ or O₂ content, and record these in the report on page 136.

Note

To prevent operating faults and damage, operate the appliance with uncontaminated combustion air.

Permissible CO content

The CO content must be < 1000 ppm for all gas types.

Permissible CO₂ or O₂ content

Operation with natural gas

Rated heating output (kW)	CO ₂ content (%)		O ₂ content (%)	
	Upper heating output	Lower heating output	Upper heating output	Lower heating output
11	7.3 to 10.5	7.5 to 10.5	2.1 to 7.9	2.1 to 7.6
19	7.3 to 10.5	7.5 to 10.5	2.1 to 7.9	2.1 to 7.6
25	7.3 to 10.5	7.5 to 10.5	2.1 to 7.9	2.1 to 7.6
32	7.3 to 10.5	7.5 to 10.5	2.1 to 7.9	2.1 to 7.6

Operation with LPG

- CO₂ content: 8.4 to 11.8 %
- O₂ content: 3.1 to 8.1 %

If the actual CO, CO₂ or O₂ values lie outside their respective ranges, proceed as follows:

- Check the balanced flue system for leaks; see page 50.
- Check the ionisation electrode and connecting cable; see page 53.

Note

During commissioning, the combustion controller carries out an automatic calibration. Allow approx. 50 s after the burner has started before testing the emissions.

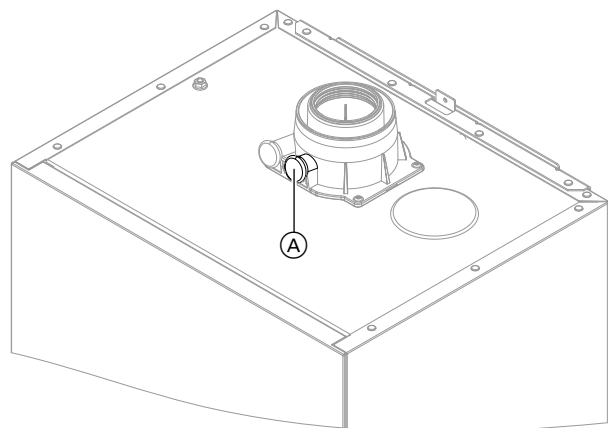

Fig. 50



Checking the combustion quality (cont.)

1. Connect a flue gas analyser at flue gas port (A) on the boiler flue connection.
2. Open the gas shut-off valve. Start the boiler. Create a heat demand.
3. Adjust the lower heating output. See the following chapter.
4. Check the CO₂ content. If the actual value deviates from the permissible ranges, implement steps listed above.
5. Enter the actual value into the report.
6. Adjust the upper heating output. See the following chapter.
7. Check the CO₂ content. If the actual value deviates from the permissible ranges by more than 1 %, implement steps listed above.
8. Enter the actual value into the report.
9. Re-seal test port (A).



Danger

Escaping flue gas can damage your health. Check test port (A) for leaks.

Selecting the upper/lower heating output

Note

Ensure adequate heat transfer.

Tap the following buttons:

- 1.
2. "Service"
3. Enter password "viservice".
4. Confirm with .
5. "Actuator test"
6. Confirm with .
7. Select "**Burner modulation, set value**".
The boiler circuit pump operates automatically at 100 %.
8. Set the lower heating output:
Select "**Minimum heating output**".
The burner now operates at the lower heating output.
9. Set the upper heating output:
Select "**Maximum heating output**".
The burner now operates at the upper heating output.
10. End output selection:
 or



Checking the flue system for unrestricted flow and leaks



Checking the external LPG safety valve (if installed)



Matching the control unit to the heating system

The control unit must be matched to the system equipment level.
Set the parameters according to the accessories fitted:



Accessory installation instructions



Adjusting heating curves

Tap the following buttons:

- 1.
2. "Heating"
3. Select "**Heating circuit 1**" or "**Heating circuit ...**" for the required heating circuit.
4. "**Heating curve**"



Adjusting heating curves (cont.)

5. Set the heating curve according to the requirements of the system using **"Slope"**+/- or **"Level"** +/-.
6. ✓ to confirm



Calling up and resetting the maintenance display

In the following cases, Δ will be displayed (red indicator flashes):

- The specified limits have been reached.
- There is cause for a warning.

Checking maintenance messages

- 1.
2. For **"Message lists"**
3. For **"Service"**

Acknowledging a service

1. to acknowledge the maintenance messages
2. ✓ to confirm

Note

An acknowledged service message that was not reset reappears the following Monday.

After maintenance has been carried out (Reset service)

- 1.
2. **"Service"**
3. Enter password **"viservice"**.
4. Confirm with .
5. **"System configuration"**
6. **"Boiler"**
7. Select parameter **1411.0 "Clear maintenance messages"** and **"ON"**.

Note

The selected service parameters for hours run and time intervals restart at 0.



Instructing the system user

The system installer should hand the operating instructions to the system user and instruct the user in operating the system.

This includes all components installed as accessories, e.g. remote control units. In addition, the system installer must make the user aware of the required maintenance work.

DHW hygiene

For optimum DHW hygiene, avoid DHW temperatures that are < 50 °C. For larger systems and systems with low water exchange, the temperature should not drop below < 60 °C.

To activate the function, see the operating instructions. Inform the system user what DHW temperatures should be set and the risks associated with having a raised outlet temperature at the draw-off points.

Hygiene function

The DHW can be heated to a specified (higher) set DHW temperature for a period of one hour.

Calling up parameters

- Parameters are split into the following groups:
 - "General"
 - "Boiler"
 - "DHW"
 - "Heating circuit ..."
 - "Solar"
- Heating systems with one heating circuit without mixer and one or 2 heating circuits with mixer:

In the following, the heating circuit without mixer is designated "**Heating circuit 1**" and the heating circuits with mixer "**Heating circuit 2**" ... (if installed). If the heating circuits have been designated individually, the chosen designation appears.

Note

The display and setting of some parameters is dependent on:

- Heat generator
- Connected accessories and the functions associated with them

Tap the following buttons:

1. 

2. "Service"

3. Enter password "**viservice**".

4. Use  to confirm.

5. "System configuration"

6. Select group.

7.  to select parameters.

8. 

9.  for the required value according to the following tables.

10. , to accept the set value.

General

Note

Parameter values in **bold** are factory settings.

508.0 "UTC time zone"

Setting	Explanations
2 –24 to +24	Setting of the UTC time zone in which the appliance is located. The factory setting is UTC +1 h Time difference adjustable from –12 h to +12 h in increments of 0.5 h

528.0 "Set flow temperature for external demand"

Setting	Explanations
70 20 to 82	Set flow temperature for external demand Set flow temperature in the delivered condition 70 °C Set flow temperature adjustable from 20 to 82 °C in 1 °C increments

896.0 "Display correction for outside temperature"

Setting	Explanations
0 –10 to +10	Correction of measured outside temperature No correction Correction adjustable from –10 to +10 K

General (cont.)**897.0 "Screed drying"**

Setting		Explanations
Not active	0	Screed drying can be set in accordance with selectable temperature/time profiles. For individual profile curves, see chapter "Function description".
Chart A	2	
Chart B	3	
Chart C	4	
Chart D	5	
Chart E	6	
Chart F	7	

912.0 "Automatic summer/wintertime changeover"

Setting		Explanations
No	0	Automatic changeover disabled
Yes	1	Automatic changeover enabled

912.1 "Earliest day of changeover from winter to summertime"

Setting		Explanations
	25	Changeover from 02:00 h to 03:00 h occurs on the Sunday after or on this set date.
	1 to 31	Day of changeover adjustable from 1st to 31st of the month

912.2 "Month of changeover from winter to summertime"

Setting		Explanations
	3	Month of changeover: March
	1 to 12	Month of changeover adjustable from January to December

912.3 "Earliest day of changeover from summer to wintertime"

Setting		Explanations
	25	Changeover from 03:00 h to 02:00 h occurs on the Sunday after or on this set date.
	1 to 31	Day of changeover adjustable from 1st to 31st of the month

912.4 "Month of changeover from summer to wintertime"

Setting		Explanations
	10	Month of changeover: October
	1 to 12	Month of changeover adjustable from January to December

1098.4 "Gas volume correction factor"

Setting		Explanations
	1.0000	Value is provided on the gas supplier's bill. Used for gas consumption data.
	0.7000 to 1.0000	Gas volume correction factor adjustable from 0.7000 to 1.0000 in increments of 0.0001.

System configuration (parameters)

General (cont.)

1098.5 "Calorific value"

Setting		Explanations
	10.0000	Value is provided on the gas supplier's bill. Used for gas consumption data.
	5.0000 to 40.0000	Calorific value adjustable from 5.0000 to 40.0000 kWh/m ³ in increments of 0.0001

1139.0 "Outside temperature limit for cancelling reduced set room temperature"

Setting		Explanations
	-5	Temperature limit for cancelling reduced set room temperature
	-61 to +10	Temperature limit in the delivered condition -5 °C Temperature limit adjustable from -61 to +10 °C in 1 °C increments

1139.1 "Outside temperature limit for raising the reduced set room temperature to the standard set room temperature"

Setting		Explanations
	-14	Temperature limit for raising the reduced set room temperature (see function description)
	-60 to +10	Temperature limit in the delivered condition -14 °C Temperature limit adjustable from -60 to +10 °C in 1 °C increments

1504.0 "Source for date and time"

Setting		Explanations
Local	0	Selection of source for date and time The setting depends on the heat generator and accessories. Factory setting: The date and time are adopted from the control unit.
	1	Internet protocol (see parameter "508.0")

Boiler

Note

Parameter values in **bold** are factory settings.

521.0 "Time interval in burner hours until the next service"

Setting		Explanations
	0	Number of burner hours to run until next service
	0 to 25500	Burner hours until next service adjustable from 0 to 25500

Boiler (cont.)**522.3 "Interval until the next service"**

Setting		Explanations
	0	Interval until the next service
	1	No interval selected
	2	3 months
	3	6 months
	4	12 months
	5	18 months
		24 months

596.0 "Maximum heating output"

Setting		Explanations
	100	A limit can be set on the maximum heating output for heating mode.
	0 to 100	Heating output in the delivered condition 100 % Adjustable from 0 to 100 %

597.0 "Limit, max. heating output for DHW heating"

Setting		Explanations
	100	A limit can be set on the maximum heating output for DHW heating.
	0 to 100	Heating output in the delivered condition 100 % Adjustable from 0 to 100 %

1100.2 "Set speed of the primary circuit pump in heating mode"

Setting		Explanations
	...	Target speed of internal circulation pump <ul style="list-style-type: none"> ▪ In heating operation ▪ With external demand ▪ With demand in conjunction with a low loss header Factory settings defined by settings specific to the appliance The setting range depends on the appliance

1240.0 "Operating mode of primary circuit pump"

Setting		Explanations
	1	"Automatic"
	7	Switched on regardless of current temperature level Shutdown in reduced mode (in conjunction with continuous operation or when no demand via room thermostat)

1411.0 "Clear maintenance messages"

Setting		Explanations
No	0	Clear maintenance messages once maintenance has been performed.
Yes	1	Maintenance messages are active (if present). Clear maintenance messages once.

System configuration (parameters)

Boiler (cont.)

1503.0 "Minimum heating output"

Setting		Explanations
	...	A limit can be set on the minimum heating output for heating mode.
	5 to 100	Delivered condition specified by settings specific to the appliance Adjustable from 5 to 100 %

1606.0 "Minimum burner pause time"

Setting		Explanations
	0	The minimum burner pause time can be set subject to boiler load.
	1	Fixed setting for minimum burner pause time Delivered condition, integral method (see parameter 1606.4)

1606.4 "Integral threshold for burner switch-off"

Setting		Explanations
	50	Only effective if parameter 1606.0 has been set to 1. Factory setting 50 K x min
	5 to 255	Adjustable from 5 to 255 K x min The higher the value, the later the burner switches off.

DHW

Note

Parameter values in **bold** are factory settings.

497.0 " Operating mode of DHW circulation pump"

Setting		Explanations
	0	DHW circulation pump: Time program
	4	Selected cycle (see parameter 497.3)

497.1 "DHW circulation pump for hygiene function"

Setting		Explanations
OFF	0	Activation criterion for the DHW circulation pump when the function "Increased DHW hygiene" is active According to time program
ON	1	Switched on if function "Increased DHW hygiene" is active
		 Danger High DHW temperatures may cause scalding. <ul style="list-style-type: none"> ▪ Where necessary implement on-site measures. E.g. install automatic thermostatic mixing valves in the DHW pipe. ▪ Inform the system operator. ▪ Admix cold water at the draw-off points.

DHW (cont.)**497.2 "DHW circulation pump for DHW heating"**

Setting		Explanations
OFF	0	Activation criterion for DHW circulation pump According to time program
ON	1	ON during DHW heating to set cylinder temperature

497.3 "Number of cycles DHW circulation pump"

Setting		Explanations
		Within the time phase, the DHW circulation pump is switched on cyclically for 5 min at a time. Number of switching cycles per hour:
	0	1 switching cycle
	1	2 switching cycles
	2	3 switching cycles
	3	4 switching cycles
	4	5 switching cycles
	5	6 switching cycles

503.0 "Scald protection"

Setting		Explanations
OFF	0	The adjustable water temperature is limited to a maximum value. Scald protection OFF
		 Danger Risk of injury due to increased DHW temperature. Inform the system user of the risk from the higher outlet temperature at the taps.
ON	1	Scald protection ON (maximum DHW temperature 60 °C)
		Note <i>Even with the scald protection switched on, higher outlet temperatures may occur at the draw-off points in the following cases:</i>
		<ul style="list-style-type: none"> ▪ With active hygiene function ▪ While the appliance is being calibrated

534.0 "Circulation pump run-on"

Setting		Explanations
120 s	120 0 to 900	Circulation pump run-on after cylinder heating Delivered condition 120 s run-on Run-on time adjustable from 0 to 900 s in 60 s increments (the run-on time is rounded down to full minutes)
		Note <i>To avoid damaging the appliance, do not set the run-on time to < 120 s.</i>

System configuration (parameters)

DHW (cont.)

1085.0 "Cylinder heating: Set start point"

Setting	Explanations
25 10 to 100	<p>Start point for DHW heating below set cylinder temperature</p> <p>Note <i>Not adjustable on storage combi boilers!</i></p> <p>Start point 2.5 K below set cylinder temperature</p> <p>Adjustable start points: 10: 1.0 K ... 100: 10.0 K</p> <p>Note <i>Stop point 2.5 K above set cylinder temperature</i></p>

1087.0 "Max. duration, DHW heating"

Setting	Explanations
240 0 1 to 240	<p>After a set period of time has elapsed, DHW heating ends even though the set DHW temperature has not yet been reached.</p> <p>Not adjustable on gas condensing combi boilers</p> <p>Factory setting 240 min</p> <p>No time limit for DHW heating</p> <p>Duration of DHW heating adjustable from 1 to 240 min in 1 min increments</p>

1087.1 "Min. delay until next DHW heating"

Setting	Explanations
60 60 to 240	<p>Minimum delay before DHW heating starts again, even though there is a demand.</p> <p>Note <i>Function becomes effective when the set "Max. duration, DHW heating" (1087.0) is exceeded.</i></p> <p>Cannot be adjusted on gas condensing combi boilers</p> <p>Delivered condition, delay of 60 min</p> <p>Delay adjustable from 60 to 240 min in 1 min increments</p>

1101.2 "Set speed of the primary circuit pump for DHW heating"

Setting	Explanations
...	<p>Target speed of the internal circulation pump when operated as a DHW pump</p> <p>Factory settings defined by settings specific to the appliance</p> <p>The setting range depends on the appliance.</p>

Heating circuit 1, Heating circuit 2, Heating circuit 3, Heating circuit 4

Note

Parameter values in **bold** are factory settings.

Heating circuit 1, Heating circuit 2, Heating... (cont.)

424.3 "Set flow temperature increased when switching from operation with reduced room temperature to operation with standard/comfort room temperature, heating circuit 1"

Setting		Explanations
0 K	0 0 to 20	Set flow temperature increased when changing from operation at reduced room temperature to operation at standard room temperature or comfort room temperature. See also chapter "Function description" Delivered condition increase 0 K Temperature rise adjustable from 0 to 20 K

424.4 "Duration for set flow temperature increase, heating circuit 1"

Setting		Explanations
60 min	60 0 to 120	Duration for set flow temperature increase See also chapter "Function description" Delivered condition 60 min Temperature rise adjustable from 0 to 120 min

426.3 "Set flow temperature increased when switching from operation with reduced room temperature to operation with standard/comfort room temperature, heating circuit 2"

Setting		Explanations
0 K	0 0 to 20	Set flow temperature increased when changing from operation at reduced room temperature to operation at standard room temperature or comfort room temperature. See also chapter "Function description" Delivered condition increase 0 K Temperature rise adjustable from 0 to 20 K

426.4 "Duration for set flow temperature increase, heating circuit 2"

Setting		Explanations
60 min	60 0 to 120	Duration for set flow temperature increase See also chapter "Function description" Delivered condition 60 min Temperature rise adjustable from 0 to 120 min

428.3 "Set flow temperature increased when switching from operation with reduced room temperature to operation with standard/comfort room temperature, heating circuit 3"

Setting		Explanations
0 K	0 0 to 20	Set flow temperature increased when changing from operation at reduced room temperature to operation at standard room temperature or comfort room temperature. See also chapter "Function description" Delivered condition increase 0 K Temperature rise adjustable from 0 to 20 K

428.4 "Duration for set flow temperature increase, heating circuit 3"

Setting		Explanations
60 min	60 0 to 120	Duration for set flow temperature increase See also chapter "Function description" Delivered condition 60 min Temperature rise adjustable from 0 to 120 min

Heating circuit 1, Heating circuit 2, Heating... (cont.)

430.3 "Set flow temperature increased when switching from operation with reduced room temperature to operation with standard/comfort room temperature, heating circuit 4"

Setting		Explanations
0 K	0 0 to 20	Set flow temperature increased when changing from operation at reduced room temperature to operation at standard room temperature or comfort room temperature. See also chapter "Function description" Delivered condition increase 0 K Temperature rise adjustable from 0 to 20 K

430.4 "Duration for set flow temperature increase, heating circuit 4"

Setting		Explanations
60 min	60 0 to 120	Duration for set flow temperature increase See also chapter "Function description" Delivered condition 60 min Temperature rise adjustable from 0 to 120 min

933.3 "Priority, DHW heating, heating circuit 1"

Setting		Explanations
Off	0	Priority of DHW heating over the heating circuit No priority for DHW heating (only if the DHW cylinder is installed downstream of the low loss header)
DHW	1	With DHW heating priority

933.6 "Operating mode of heating circuit 1"

Setting		Explanations
Weather-compensated without room temperature hook-up	4	Only adjust for systems with one heating circuit. Heating mode: Weather-compensated without room temperature influence
Weather-compensated with room temperature hook-up	7	Weather-compensated with room temperature influence (see also parameter 933.7)

933.7 "Room influence factor, heating circuit 1"

Setting		Explanations
	8 0 to 64	The higher the value, the greater the influence of the room temperature on the set flow temperature of the heating circuit (heating curve). Operation with room temperature hook-up must be set for the heating circuit (parameter 933.6). Only change the value for systems with one heating circuit. For a sample calculation, see chapter "Heating curve" in the "Function description" Room influence factor Room influence adjustable from 0 to 64

Heating circuit 1, Heating circuit 2, Heating... (cont.)

934.3 "Priority, DHW heating, heating circuit 2"

Setting		Explanations
OFF	0	Priority of DHW heating over heating circuit pump and mixer No priority for DHW heating (only if the DHW cylinder is installed downstream of the low loss header)
DHW	1	With DHW heating priority

934.5 "Differential temperature, heating circuit 2"

Setting		Explanations
8 K	8 0 to 20	The flow temperature of the heat generator is higher than the flow temperature of the heating circuit with mixer by an adjustable differential temperature. See also chapter "Function description". Differential temperature in delivered condition 8 K Differential temperature adjustable from 0 to 20 K

934.6 "Operating mode of heating circuit 2"

Setting		Explanations
Weather-compensated without room temperature hook-up	4	Heating mode: Weather-compensated without room temperature influence
Weather-compensated with room temperature hook-up	7	Weather-compensated with room temperature influence See also parameter 934.7

934.7 "Room influence factor, heating circuit 2"

Setting		Explanations
	8 0 to 64	The higher the value, the greater the influence of the room temperature on the set flow temperature of the heating circuit (heating curve). Operation with room temperature hook-up must be set for the heating circuit (parameter 934.6). Change value for heating circuit with mixer only. For a sample calculation, see chapter "Heating curve" in the "Function description" Room influence factor Room influence adjustable from 0 to 64

935.3 "Priority, DHW heating, heating circuit 3"

Setting		Explanations
OFF	0	Priority of DHW heating over heating circuit pump and mixer No priority for DHW heating (only if the DHW cylinder is installed downstream of the low loss header)
DHW	1	With DHW heating priority

Heating circuit 1, Heating circuit 2, Heating... (cont.)

935.5 "Differential temperature, heating circuit 3"

Setting		Explanations
8 K	8 0 to 20	The flow temperature of the heat generator is higher than the flow temperature of the heating circuit with mixer by an adjustable differential temperature. See also chapter "Function description". Differential temperature in delivered condition 8 K Differential temperature adjustable from 0 to 20 K

935.6 "Operating mode of heating circuit 3"

Setting		Explanations
Weather-compensated without room temperature hook-up	4	Heating mode: Weather-compensated without room temperature influence
Weather-compensated with room temperature hook-up	7	Weather-compensated with room temperature influence See also parameter 935.7

935.7 "Room influence factor, heating circuit 3"

Setting		Explanations
	8 0 to 64	The higher the value, the greater the influence of the room temperature on the set flow temperature of the heating circuit (heating curve). Operation with room temperature hook-up must be set for the heating circuit (parameter 935.6). Change value for heating circuit with mixer only. For a sample calculation, see chapter "Heating curve" in the "Function description" Room influence factor Room influence adjustable from 0 to 64

936.3 "Priority, DHW heating, heating circuit 4"

Setting		Explanations
Off	0	Priority of DHW heating over heating circuit pump and mixer No priority for DHW heating (only if the DHW cylinder is installed downstream of the low loss header)
DHW	1	With DHW heating priority

936.5 "Differential temperature, heating circuit 4"

Setting		Explanations
8 K	8 0 to 20	The flow temperature of the heat generator is higher than the flow temperature of the heating circuit with mixer by an adjustable differential temperature. See also chapter "Function description". Differential temperature in delivered condition 8 K Differential temperature adjustable from 0 to 20 K

Heating circuit 1, Heating circuit 2, Heating... (cont.)

936.6 "Operating mode heating circuit 4"

Setting		Explanations
Weather-compensated without room temperature hook-up	4	See also parameter 936.7 Heating mode: Weather-compensated without room temperature influence Weather-compensated with room temperature influence
Weather-compensated with room temperature hook-up	7	

936.7 "Room influence factor, heating circuit 4"

Setting		Explanations
	8 0 to 64	The higher the value, the greater the influence of the room temperature on the set flow temperature of the heating circuit (heating curve). Operation with room temperature hook-up must be set for the heating circuit (parameter 936.6). Change value for heating circuit with mixer only. For a sample calculation, see chapter "Heating curve" in the "Function description" Room influence factor Room influence adjustable from 0 to 64

1102.0 "Min. speed of speed-controlled primary/heating circuit pump in standard mode, heating circuit 1"

Setting		Explanations
	...	Minimum speed of the internal circulation pump in heating mode with standard room temperature Delivered condition specified by settings specific to the heat generator Setting range depends on the appliance.

1102.1 "Max. speed of speed-controlled primary/heating circuit pump in standard mode, heating circuit 1"

Setting		Explanations
	...	Maximum speed of the internal circulation pump in heating mode with standard room temperature Delivered condition specified by settings specific to the heat generator Setting range depends on the appliance.

1192.0 "Minimum flow temperature limit, heating circuit 1"

Setting		Explanations
20 °C	20 1 to 90	Minimum flow temperature limit for the heating circuit Min flow temperature 20 °C Setting range limited by parameters, depending on appliance variant

1192.1 "Maximum flow temperature limit, heating circuit 1"

Setting		Explanations
74 °C	74 10 to 100	Maximum flow temperature limit for the heating circuit Max. flow temperature 74 °C Setting range limited by parameters, depending on appliance variant

Heating circuit 1, Heating circuit 2, Heating... (cont.)**1193.0 "Minimum flow temperature limit, heating circuit 2"**

Setting		Explanations
20 °C	20 1 to 90	Minimum flow temperature limit for the heating circuit Min flow temperature 20 °C Setting range limited by parameters, depending on appliance variant

1193.1 "Maximum flow temperature limit, heating circuit 2"

Setting		Explanations
74 °C	74 10 to 100	Maximum flow temperature limit for the heating circuit Max. flow temperature 74 °C Setting range limited by parameters, depending on appliance variant

1194.0 "Minimum flow temperature limit, heating circuit 3"

Setting		Explanations
20 °C	20 1 to 90	Minimum flow temperature limit for the heating circuit Min flow temperature 20 °C Setting range limited by parameters, depending on appliance variant

1194.1 "Maximum flow temperature limit, heating circuit 3"

Setting		Explanations
74 °C	74 10 to 100	Maximum flow temperature limit for the heating circuit Max. flow temperature 74 °C Setting range limited by parameters, depending on appliance variant

1195.0 "Minimum flow temperature limit, heating circuit 4"

Setting		Explanations
20 °C	20 1 to 90	Minimum flow temperature limit for the heating circuit Min flow temperature 20 °C Setting range limited by parameters, depending on appliance variant

1195.1 "Maximum flow temperature limit, heating circuit 4"

Setting		Explanations
74 °C	74 10 to 100	Maximum flow temperature limit for the heating circuit Max. flow temperature 74 °C Setting range limited by parameters, depending on appliance variant

Heating circuit 1, Heating circuit 2, Heating... (cont.)

1395.1 "Heating limit: Economy function, outside temperature, heating circuit 1"

Setting		Explanations
25 °C	25 10 to 35	Heating circuit pump logic function (summer economy control): Heating circuit pump switches off when outside temperature is 1 K above selected value. Heating circuit pump switches back on when outside temperature is 1 K below selected value. Heating limit at outside temperature 25 °C Heating limit adjustable from 10 to 35 °C

1396.1 "Heating limit: Economy function, outside temperature, heating circuit 2"

Setting		Explanations
25 °C	25 10 to 35	Heating circuit pump logic function (summer economy control): Heating circuit pump switches off when outside temperature is 1 K above selected value. Heating circuit pump switches back on when outside temperature is 1 K below selected value. Heating limit at outside temperature 25 °C Heating limit adjustable from 10 to 35 °C

1397.1 "Heating limit: Economy function, outside temperature, heating circuit 3"

Setting		Explanations
25 °C	25 10 to 35	Heating circuit pump logic function (summer economy control): Heating circuit pump switches off when outside temperature is 1 K above selected value. Heating circuit pump switches back on when outside temperature is 1 K below selected value. Heating limit at outside temperature 25 °C Heating limit adjustable from 10 to 35 °C

1398.1 "Heating limit: Economy function, outside temperature, heating circuit 4"

Setting		Explanations
25 °C	25 10 to 35	Heating circuit pump logic function (summer economy control): Heating circuit pump switches off when outside temperature is 1 K above selected value. Heating circuit pump switches back on when outside temperature is 1 K below selected value. Heating limit at outside temperature 25 °C Heating limit adjustable from 10 to 35 °C

Energy saving functions (setting only via software tool)**1791.0 "3-way valve target position"**

Setting		Explanations
1. Heating 2. Central position 3. DHW		The 3-way valve assumes the set position when there is no demand from heating operation or DHW heating.

Heating circuit 1, Heating circuit 2, Heating... (cont.)**2426.1 "Weather-compensated heating circuit pump logic for heating circuit 1" (only for weather-compensated control units)**

Setting		Explanations
	Setting range -9 to +5 °C	If the outside temperature rises above the threshold value (set room temperature plus offset in K), the heating circuit pump is switched off. If the outside temperature falls below the threshold value (set room temperature plus offset in K), the heating circuit pump is switched on.

2426.3 "Room temperature-dependent heating circuit pump logic for heating circuit 1" (only for weather-compensated control units with room temperature hook-up).

Setting		Explanations
Only activate this function for the heating circuit with mixer or if there is only one direct heating circuit in the system.	Setting range -2 to +5 °C	If the actual room temperature rises above the threshold value (set room temperature plus offset in K), the heating circuit pump is switched off. If the actual room temperature falls below the threshold value (set room temperature plus offset in K), the heating circuit pump is switched on.

2427.1 "Weather-compensated heating circuit pump logic for heating circuit 2" (only for weather-compensated control units).

Setting		Explanations
	Setting range -9 to +5 °C	If the outside temperature rises above the threshold value (set room temperature plus offset in K), the heating circuit pump is switched off. If the outside temperature falls below the threshold value (set room temperature plus offset in K), the heating circuit pump is switched on.

2427.3 "Room temperature-dependent heating circuit pump logic for heating circuit 2" (only for weather-compensated control units with room temperature hook-up).

Setting		Explanations
Only activate this function for the heating circuit with mixer or if there is only one direct heating circuit in the system.	Setting range -2 to +5 °C	If the actual room temperature rises above the threshold value (set room temperature plus offset in K), the heating circuit pump is switched off. If the actual room temperature falls below the threshold value (set room temperature plus offset in K), the heating circuit pump is switched on.

2428.1 "Weather-compensated heating circuit pump logic for heating circuit 3" (only for weather-compensated control units).

Setting		Explanations
	Setting range -9 to +5 °C	If the outside temperature rises above the threshold value (set room temperature plus offset in K), the heating circuit pump is switched off. If the outside temperature falls below the threshold value (set room temperature plus offset in K), the heating circuit pump is switched on.

Heating circuit 1, Heating circuit 2, Heating... (cont.)

2428.3 "Room temperature-dependent heating circuit pump logic for heating circuit 3" (only for weather-compensated control units with room temperature hook-up).

Setting		Explanations
Only activate this function for the heating circuit with mixer or if there is only one direct heating circuit in the system.	Setting range -2 to +5 °C	If the actual room temperature rises above the threshold value (set room temperature plus offset in K), the heating circuit pump is switched off. If the actual room temperature falls below the threshold value (set room temperature plus offset in K), the heating circuit pump is switched on.

2429.1 "Weather-compensated heating circuit pump logic for heating circuit 4" (only for weather-compensated control units).

Setting		Explanations
	Setting range -9 to +5 °C	If the outside temperature rises above the threshold value (set room temperature plus offset in K), the heating circuit pump is switched off. If the outside temperature falls below the threshold value (set room temperature plus offset in K), the heating circuit pump is switched on.

2429.3 "Room temperature-dependent heating circuit pump logic for heating circuit 4" (only for weather-compensated control units with room temperature hook-up).

Setting		Explanations
Only activate this function for the heating circuit with mixer or if there is only one direct heating circuit in the system.	Setting range -2 to +5 °C	If the actual room temperature rises above the threshold value (set room temperature plus offset in K), the heating circuit pump is switched off. If the actual room temperature falls below the threshold value (set room temperature plus offset in K), the heating circuit pump is switched on.

Parameter setting only via software tool**2855.1 "Additional (passive) frost protection configuration, heating circuit 1"**

Setting		Explanations
	1	= 1 °C Setting range: -9 °C to +3 °C If the outside temperature falls below the set outside temperature limit, the corresponding heating circuit pump switches on (applies only to weather-compensated operation).

2856.1 "Additional (passive) frost protection configuration, heating circuit 2"

Setting		Explanations
	1	= 1 °C Setting range: -9 °C to +3 °C If the outside temperature falls below the set outside temperature limit, the corresponding heating circuit pump switches on (applies only to weather-compensated operation).

System configuration (parameters)

Heating circuit 1, Heating circuit 2, Heating... (cont.)

2857.1 "Additional (passive) frost protection configuration, heating circuit 3"

Setting		Explanations
	1	= 1 °C Setting range: -9 °C to +3 °C If the outside temperature falls below the set outside temperature limit, the corresponding heating circuit pump switches on (applies only to weather-compensated operation).

2858.1 "Additional (passive) frost protection configuration, heating circuit 4"

Setting		Explanations
	1	= 1 °C Setting range: -9 °C to +3 °C If the outside temperature falls below the set outside temperature limit, the corresponding heating circuit pump switches on (applies only to weather-compensated operation).

Solar

Note

Parameter values in **bold** are factory settings.

950.0 "Flow rate, solar circuit at max. pump speed"

Setting		Explanations
7.0 l/min	7	Flow rate required to determine the solar yield Flow rate 7 l/min
0.1 to 25.5 l/min	0.1 to 25.5	Flow rate adjustable from 0.1 to 25.5 l/min 1 step \pm 0.1 l/min

1118.0 "Min. solar circuit pump speed"

Setting		Explanations
	23	Minimum speed of solar circuit pump in % Minimum speed 23 %
	0 to 100	Speed adjustable from 0 to 100 %

1118.1 "Max. solar circuit pump speed"

Setting		Explanations
	84	Maximum speed of solar circuit pump in % Maximum speed 84 %
	0 to 100	Speed adjustable from 0 to 100 %

Solar (cont.)**1125.0 "Maximum cylinder temperature for solar DHW heating"**

Setting		Explanations
60 °C	60 10 to 90	<p>Maximum set cylinder temperature for solar DHW heating</p> <p>Max. set cylinder temperature 60 °C</p> <p>Max. set cylinder temperature adjustable from 10 to 90 °C</p> <p> Danger High DHW temperatures can cause scalding.</p> <ul style="list-style-type: none"> ▪ Where necessary implement on-site measures. E.g. install an automatic thermostatic mixing valve in the DHW pipe. ▪ Inform the system operator. ▪ Admix cold water at the draw-off points.

1126.0 "Minimum collector temperature"

Setting		Explanations
10 °C	10	Minimum collector temperature for starting the solar circuit pump
None	0	Minimum start temperature 10 °C
	1 to 90	Minimum temperature limit disabled
		Minimum start temperature adjustable from 1 to 90 °C

1126.1 "Maximum collector temperature"

Setting		Explanations
130 °C	130	When the maximum collector temperature is exceeded, the solar circuit pump is switched off to protect the system components (emergency collector shutdown).
20 - 200 °C	20 to 200	Stop temperature 130 °C
		Stop temperature adjustable from 20 to 200 °C

1127.0 "Frost protection function for solar circuit"

Setting		Explanations
Off	0	Frost protection function for the solar circuit:
On	1	Not active
		Enabled
		Not required for Viessmann heat transfer medium

1136.2 "Heat transfer medium, solar circuit"

Setting		Explanations
Calculation of solar yield with water as heat transfer medium	0	Setting of heat transfer medium for calculating solar yield
Calculation of solar yield with Viessmann heat transfer medium	1	Water as a heat transfer medium
		Viessmann heat transfer medium

System configuration (parameters)

Solar (cont.)

1394.0 "DHW temperature target, reheating suppression"

Setting		Explanations
40 °C	40 0 to 95	Set cylinder temperature for reheating suppression Above the selected set cylinder temperature, reheating suppression is active. Reheating suppression from set cylinder temperature 40 °C Set cylinder temperature adjustable from 0 to 95 °C

1492.0 "Start temperature differential, solar circuit pump"

Setting		Explanations
8 K	8 2 to 30	Start temperature differential between actual cylinder temperature and actual collector temperature Start temperature differential 8 K Start temperature differential adjustable from 2 to 30 K

1492.1 "Stop temperature differential, solar circuit pump"

Setting		Explanations
4 K	4 1 to 29	Stop temperature differential between actual cylinder temperature and actual collector temperature Stop temperature differential 4 K Stop temperature differential adjustable from 1 to 29 K

1505.0 "Stagnation time reduction"

Setting		Explanations
5 K	5 0 1 to 40	Hysteresis for set cylinder temperature Note <i>To protect system components and the heat transfer medium, the solar circuit pump speed is reduced at the same time.</i> Temperature differential 5 K Stagnation time reduction not active Temperature differential adjustable from 1 to 40 K

1598.0 "Start temperature for thermostat function"

Setting		Explanations
50 °C	50 0 to 100	Temperature for activating the thermostat function <ul style="list-style-type: none"> ▪ Do not set in conjunction with parameter 1599.... ▪ Only in conjunction with SDIO/SM1A electronics module Set start temperature adjustable from 0 to 100 °C

1598.1 "Stop temperature for thermostat function"

Setting		Explanations
40 °C	40 0 to 100	Temperature for deactivating the thermostat function Do not set in conjunction with parameter 1599.... Only in conjunction with SDIO/SM1A electronics module Set stop temperature adjustable from 0 to 100 °C

Solar (cont.)**1599.0 "Start temperature differential for central heating backup/solar preheating"**

Setting		Explanations
8 K	8 2 to 30	Temperature differential at which the solar DHW cylinder heating is switched on. <ul style="list-style-type: none"> ▪ In case of central heating backup: Temperature differential between heating return temperature and heating water temperature in the DHW cylinder. ▪ In case of solar preheating: Temperature differential between DHW temperature and heating water temperature in the DHW cylinder. Do not set in conjunction with parameter 1598.... Only in conjunction with SDIO/SM1A electronics module Start temperature differential adjustable from 2 to 30 K

1599.1 "Stop temperature differential for central heating backup/solar preheating"

Setting		Explanations
4 K	4 1 to 29	Temperature differential at which the solar DHW cylinder heating is switched off. <ul style="list-style-type: none"> ▪ In case of central heating backup: Temperature differential between heating return temperature and heating water temperature in the DHW cylinder. ▪ In case of solar preheating: Temperature differential between DHW temperature and heating water temperature in the DHW cylinder. Do not set in conjunction with parameter 1598.... Only in conjunction with SDIO/SM1A electronics module Stop temperature differential adjustable from 1 to 29 K

1719.0 "Interval function solar circuit pump"

Setting		Explanations
	0 1	For capturing the collector temperature, the collector circuit pump is cyclically switched on briefly. Not active Active

Subscriber numbers of connected extensions

All extensions connected to the heat generator (except the SDIO/SM1A electronics module) must have a subscriber number. The subscriber number is set on rotary switch S1 at each extension.

Subscriber numbers of connected extensions (cont.)

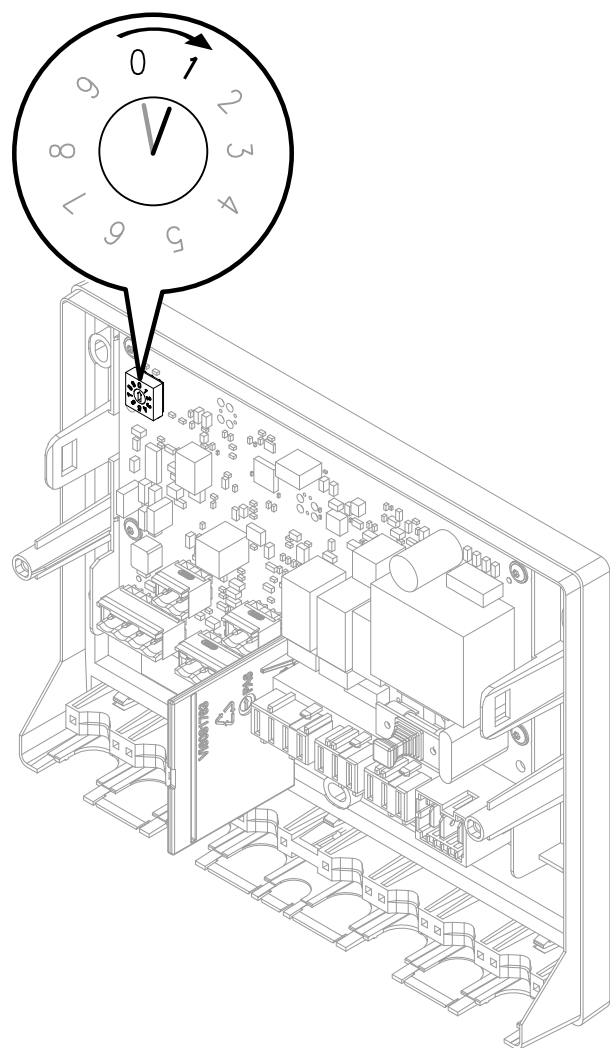

Rotary switch S1 settings:

- EM-S1 extension (system with solar collectors): **0**
- EM-EA1 extension (max. 3 extensions in one system)
 - Consecutive no. (any sequence): **1 up to 3**
- EM-P1 extension
 - If no heating circuits with mixer are available in the system: **1**
 - If heating circuits with mixer (EM-M1 or EM-MX extensions) are present in the system: Always set subscriber number for EM-P1 extension to the consecutive number after EM-M1 or EM-MX extensions.
- EM-M1 or EM-MX extensions
 - Heating circuit 2 with mixer: Rotary switch on extension kit to **1**
 - Heating circuit 3 with mixer: Rotary switch on extension kit to **2**

Note

*EM-EA1 extensions may have the same subscriber number as the EM-P1, EM-M1 or EM-MX extensions. The following table shows an **example** of how a system may be equipped.*

Fig. 51

Function	Electronics module	Extension	Setting Rotary switch S1
System with solar collectors	ADIO	EM-S1	0
Heating circuit 2 with mixer	ADIO	EM-M1/EM-MX	1
Heating circuit 3 with mixer	ADIO	EM-M1/EM-MX	2
Heating circuit 4 with mixer	ADIO	EM-M1/EM-MX	3
Heating circuit 1 without mixer (circulation pump downstream of low loss header)	ADIO	EM-P1	4
Function extensions (e.g.):	DIO	EM-EA1	1
■ Fault message input	DIO	EM-EA1	2
■ Fault message output	DIO	EM-EA1	3
■ Operating mode changeover			

Service menu

Calling up the service menu

Tap the following buttons:

1. "☰"
2. "Service"
3. Enter password "viservice".
4. Confirm with ✓.
5. Select the required menu section.

Note

Tap  to return to the "Service main menu"

Note

Not all menu areas will be available, depending on the system equipment level.

Service menu overview

Service	
Diagnosis	
	General
	Burner
	Heating circuit 1
	Heating circuit 2
	Heating circuit 3
	Heating circuit 4
	DHW
	Solar energy
	TCU communication module
Actuator test	
System configuration	
Message history	
Service functions	
	System pressure setting
	Reset service
	Filling
	Air vent valve
	System log
	WLAN Information
Energy statement reset	
Change passwords	
Commissioning	
Appliances detected	
Exit service	
Access point ON/OFF	

Exiting the service menu

Tap the following buttons:

"Exit service" or .



Note

The system exits the service menu automatically after 30 min.

Changing the service password



In the delivered condition, "viservice" is preset as the password for accessing the "Service menu".

Tap the following buttons:

1. 
2. "Service"
3. Enter password "viservice".
4. Confirm with .
5. "Change passwords".
6. "Service menu"
7. Enter current password.
8. Confirm with .
9. Enter new password.
10. Confirm twice with .

Resetting all passwords to delivered condition

Tap the following buttons:

1. Request the master password from Viessmann Technical Service.
2. 
3. "Service"
4. Enter password "viservice".
5. Confirm with .
6. "Change passwords"
7. "Reset all passwords"
8. Enter master password.
9. Confirm twice with .

Diagnosis

Checking operating data

Operating data can be called up in various areas. See "Diagnosis" in the service menu overview.

Operating data on heating circuits with mixer can only be called up if such components are installed in the system.

Note

If a called up sensor is faulty, "- - -" appears on the display.

Calling up operating data

Tap the following buttons:

1. 
2. "Service"
3. Enter password "viservice".
4. Use  to confirm.
5. "Diagnosis"
6. Select required group, e.g. "General".

Calling up messages (message history)

The messages are sorted by date.

Tap the following buttons:

1. "☰"
2. "Service"
3. Enter password "viservice".
4. Confirm with ✓.
5. "Message history"

The following is displayed in the message lists:

- Date and time of the occurrence of the notification
- Notification number
- Description of the notification
- Subscriber number of the component on which the message has occurred:
 - PlusBus subscriber components
 - 0 EM-S1 extension (ADIO electronics module)
 - 1 - 15 EM-M1, EM-MX and EM-P1 extensions (ADIO electronics module)
 - 17 - 31 EM-EA1 extension (DIO electronics module)
 - 32 - 47 Cylinder module (electronics module M2IO)
 - 49 - 63 Vitotrol 200-E
 - 64 SDIO/SM1A electronics module
 - CAN BUS subscriber components
 - 1 HMU heat management unit
 - 50 BCU burner control unit
 - 58 Communication module TCU 200
 - 59 HMI programming unit
 - 60 Fan unit
 - 90 Gateway
 - Low power radio subscriber components
 - 49 - 63 Vitotrol 300-E

6.
 - "Faults" to call up saved fault messages. For further details, see the following chapter "Fault messages".
 - "Service messages" to call up saved service messages.
 - "Status", to call up the saved status messages.
 - "Warnings" to call up saved warning messages.
 - "Information", to call up saved service information.
 For messages, see chapter "Further messages".
7. If you wish to delete messages, tap 🗑️.
8. ✓ to confirm

Checking outputs (actuator test)

Note

When the actuator test is started, all actuators are initially disabled and valves moved to their central position.

Tap the following buttons:

1. "☰"
2. "Service"
3. Enter password "viservice".
4. Confirm with ✓.

5. "Actuator test"

6. ✓ to confirm the security prompt.

Note

If an actuator function is not possible due to the running process, the function is interrupted. A message appears.

7. Use ◀▶ to select the required group. See the table below.
8. Tap the required actuator function. Several functions can be activated simultaneously.

Checking outputs (actuator test) (cont.)

9. If necessary, tap ✓ to confirm. The functions are active for 30 s.

10. Use ↩ to end the Actuator test.

The following actuator functions can be controlled subject to the system equipment level:

Display		Explanation
Gas condensing boiler group		
Fan speed	Set value	Burner fan speed in rpm (rotations/minute)
Burner modulation, set value	<ul style="list-style-type: none"> ▪ Off ▪ Minimum heating output ▪ Maximum heating output ▪ Maximum DHW output 	Modulation level (in accordance with specific heat generator settings)
3-way valve target position	Heating	3-way diverter valve set to heating mode
	Middle	3-way diverter valve in central position (filling/draining)
	DHW	3-way diverter valve set to DHW heating
Heating group		
Primary circuit pump speed	Set value	Internal circulation pump speed in %
3-way valve target position	Heating	3-way diverter valve set to heating mode
	Middle	3-way diverter valve in central position (filling/draining)
	DHW	3-way diverter valve set to DHW heating
Heating circuit 1 pump speed	Set value	Speed, heating circuit pump, heating circuit 1 without mixer in %
Heating circuit 2 pump speed	Set value	Speed, heating circuit pump, heating circuit 2 with mixer in %
Heating circuit 3 pump speed	Set value	Speed, heating circuit pump, heating circuit 3 with mixer in %
Heating circuit 4 pump speed	Set value	Speed, heating circuit pump, heating circuit 4 with mixer in %
Mixer HC2	Open	Output for "Mixer open" enabled (mixer extension kit)
	Stop	Current position is maintained
	Close	Output for "Mixer close" enabled
Mixer HC3	Open	Output for "Mixer open" enabled (mixer extension kit)
	Stop	Current position is maintained
	Close	Output for "Mixer close" enabled
Mixer HC4	Open	Output for "Mixer open" enabled (mixer extension kit)
	Stop	Current position is maintained
	Close	Output for "Mixer close" enabled
DHW group		
Primary circuit pump, set speed	Set value	Internal circulation pump in %
3-way valve target position	Heating	3-way diverter valve set to heating mode
	Middle	3-way diverter valve in central position (filling/draining)
	DHW	3-way diverter valve set to DHW heating
Circulation pump for cylinder heating	On	
	Off	

Checking outputs (actuator test) (cont.)



Display		Explanation
DHW circulation pump	On Off	
Group Solar (not for Vitodens 222-W)		
Solar circuit pump, set speed	Set value	Speed, solar circuit pump in %
Circulation pump hygiene function	On Off	
Circulation pump, solar	On Off	
3-way valve, solar	Open	
Target position	Close Stop	

Fault display on the programming unit

If there is a fault, the display shows the fault message plus .

Note

If a central fault message facility is connected, this is switched on.

1. Tap  in the footer to call up the fault messages. For an explanation of the fault codes, see the following table.
2. Tap  to hide the fault messages. For an explanation of the fault codes, see the following table.

If "Connection error" and appear on the display:

Check connecting cable and plug between HMU heat management unit and HMI programming unit.

Acknowledging the fault display

Tap .

Note

Any connected central fault message facility is switched off.

If an acknowledged fault is not remedied, the fault message will be redisplayed the following day at 07:00 h, and the fault message facility restarts.

Calling up acknowledged fault messages

Tap the following buttons:

1. 
2. Tap "Message lists".
The fault messages appear in chronological order.

Note

When troubleshooting, always observe the subscriber number of the component.
Check the component displayed, rectify the fault if required. The subscriber number of the component depends on the position of rotary switch S1 on the corresponding extension module. The rotary switch position was set during installation. To identify the affected module, check the position of rotary switch S1 on the module if required.

Note

See also page 85





The following is displayed:

- Date and time of the occurrence of the fault
- Fault code
- Description of the fault
- Subscriber number of the component on which the fault has occurred:
PlusBus subscriber components
 - 0 EM-S1 extension (ADIO electronics module)
 - 1 - 15 EM-M1, EM-MX and EM-P1 extensions (ADIO electronics module)
 - 17 - 31 EM-EA1 extension (DIO electronics module)
 - 32 - 47 Cylinder module (electronics module M2IO)
 - 48 - 63 Vitotrol 200-E
 - 64 SDIO/SM1A electronics module
- CAN BUS subscriber components
 - 1 HMU heat management unit
 - 50 BCU burner control unit
 - 58 Communication module (TCU 200)
 - 59 HMI programming unit
 - 60 Fan unit
 - 90 Gateway
- Low power radio subscriber components
 - 49 - 63 Vitotrol 300-E

Calling up fault messages from the fault memory (message history)

The 10 most recent faults (including those remedied) and service messages are saved and can be called up.
Faults are sorted by date.

Tap the following buttons:

1. 
2. "Service"
3. Enter password "viservice".
4. Confirm with .
5. "Message history"
6. "Faults" to call up saved fault messages.
7. If you wish to delete the list, tap .
8.  to confirm.

Overview of electronics modules

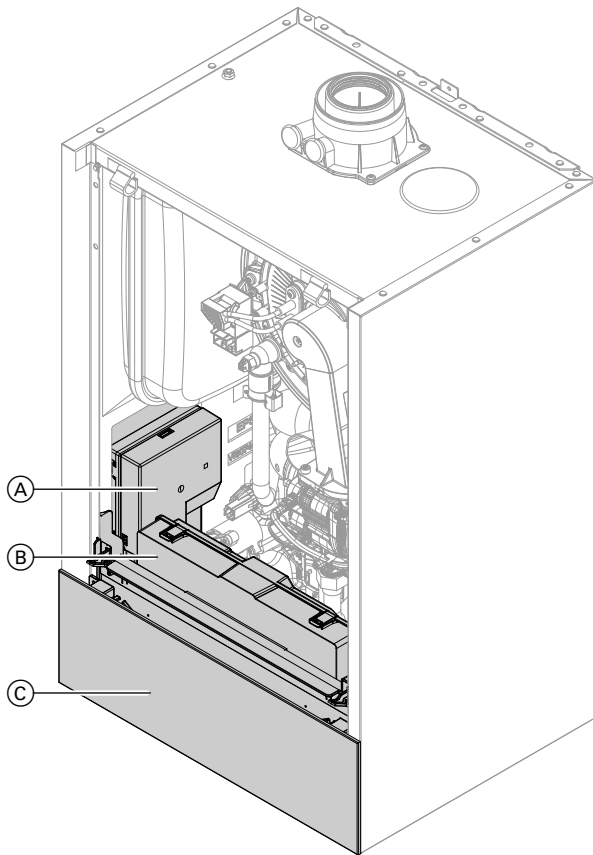

Fig. 52

- (A) BCU burner control unit
- (B) HMU heat management unit
- (C) HMI programming unit with TCU communication module

Fault messages

Note

Diagnostics and troubleshooting: See chapter "Repairs".

Fault messages dependent on appliance equipment level

Fault messages (cont.)

Displayed fault code	System characteristics	Cause	Measures
F.5	Flow rate not being monitored. System continues operating in normal mode with replacement value.	Lead break or short circuit, flow sensor.	<p>Check plug 33/X6 and cable between BCU burner control unit and flow sensor:</p> <ul style="list-style-type: none"> ▪ Check voltage level, to see if 5 V present at plug 33, pins 1 and 2. ▪ Turn the gas condensing boiler ON/OFF switch off and back on again.
F.7	No DHW heating.	Lead break, cylinder temperature sensor.	<ul style="list-style-type: none"> ▪ Check DHW setting in the commissioning assistant and correct if required. ▪ Check cylinder temperature sensor (plug 5, wires 3 and 4). ▪ Measure voltage at sensor input on electronics module. Setpoint: 3.3 V_{DC} with sensor disconnected <p>Replace faulty component if required.</p>
F.8	No DHW heating.	Short circuit, cylinder temperature sensor.	<p>Check cylinder temperature sensor (plug 5, wires 3 and 4). Replace faulty component if required.</p>
F.11	No solar DHW heating or central heating backup.	Lead break, collector temperature sensor.	<ul style="list-style-type: none"> ▪ Check collector temperature sensor. ▪ Measure voltage at sensor input on electronics module. Setpoint: 3.3 V_{DC} with sensor disconnected
F.12	No solar DHW heating or central heating backup.	Short circuit, collector temperature sensor.	<ul style="list-style-type: none"> ▪ Check collector temperature sensor. ▪ Measure voltage at sensor input on electronics module. Setpoint: 3.3 V_{DC} with sensor disconnected
F.13	Regulates as if the outside temperature were 0 °C.	Lead break, outside temperature sensor.	<ul style="list-style-type: none"> ▪ Check the operating mode setting in the commissioning assistant. Correct if necessary. ▪ Check outside temperature sensor and connection to sensor (external plug, contacts 1 and 2). <p>Note <i>Depending on appliance version, on floorstanding compact appliances the plug is located inside the appliance.</i></p> <ul style="list-style-type: none"> ▪ Measure voltage at sensor input on electronics module. Setpoint: 3.3 V_{DC} with sensor disconnected <p>Replace faulty component if required.</p>

Fault messages (cont.)

Displayed fault code	System characteristics	Cause	Measures
F.14	Regulates as if the outside temperature were 0 °C.	Short circuit, outside temperature sensor.	<p>Check outside temperature sensor and connection to sensor (external plug and contacts 1 and 2). Replace faulty components if necessary.</p> <p>Note Depending on appliance version, on floorstanding compact appliances the plug is located inside the appliance.</p>
F.15	No solar DHW heating or central heating backup.	Lead break, cylinder temperature sensor.	<p>Check cylinder temperature sensor.</p> <p>Measure voltage at sensor input on electronics module. Setpoint: 3.3 V_{DC} with sensor disconnected</p>
F.16	No solar DHW heating or central heating backup.	Short circuit, cylinder temperature sensor.	<p>Check cylinder temperature sensor.</p> <p>Measure voltage at sensor input on electronics module. Setpoint: 3.3 V_{DC} with sensor disconnected</p>
F.19	No DHW heating.	Lead break, bottom cylinder temperature sensor.	<p>Check bottom cylinder temperature sensor.</p>
F.29	Regulates without flow temperature sensor for low loss header.	Lead break, low loss header sensor.	<ul style="list-style-type: none"> ▪ Check commissioning assistant setting, low loss header. ▪ Check flow temperature sensor, low loss header. ▪ Measure voltage at sensor input on electronics module. Setpoint: 3.3 V_{DC} with sensor disconnected
F.30	Regulates without flow temperature sensor for low loss header.	Short circuit, low loss header sensor.	<p>Check flow temperature sensor, low loss header.</p> <p>Measure voltage at sensor input on electronics module. Setpoint: 3.3 V_{DC} with sensor disconnected</p>
F.49	Burner in a fault state.	Lead break, flue gas temperature sensor.	<p>Check flue gas temperature sensor.</p> <p>Reset the appliance.</p>
F.50	Burner in a fault state.	Short circuit, flue gas temperature sensor.	<p>Check flue gas temperature sensor.</p> <p>Reset the appliance.</p>
F.57	Normal operation without room influence.	Lead break, room temperature sensor.	<ul style="list-style-type: none"> ▪ Check commissioning setting of remote control. ▪ Check plug and cable of external room temperature sensor, heating circuit. ▪ If no external room temperature sensor is installed, replace Vitotrol programming unit.



Fault messages (cont.)

Displayed fault code	System characteristics	Cause	Measures
F.58	Normal operation without room influence.	Short circuit, room temperature sensor.	Check plug and cable of external room temperature sensor, heating circuit. If no external room temperature sensor is installed, replace Vitotrol programming unit.
F.59	Burner locked out. Internal circulation pump off. No central heating, no DHW heating.	Power supply, low voltage	Check mains voltage. If voltage is correct and the fault occurs repeatedly, replace the fan unit.
F.62	Burner in a fault state.	High limit safety cut-out has responded.	<ul style="list-style-type: none"> ▪ Check heating system fill level. ▪ Check pre-charge pressure in diaphragm expansion vessel. Adjust to required system pressure. ▪ Check whether flow rate is sufficient (flow sensor and circulation pump). ▪ Check 3-way diverter valve function in actuator test. Vent the system. Reset the appliance.
F.63	Burner in a fault state.	Flue gas temperature limiter has responded.	<ul style="list-style-type: none"> ▪ Check heating system fill level. ▪ Check pre-charge pressure in diaphragm expansion vessel. Adjust to required system pressure. ▪ Check whether flow rate is sufficient (flow sensor and circulation pump). ▪ Check 3-way diverter valve function in actuator test. Vent the system. Reset the appliance once the flue system has cooled down.
F.64	Normal operation Burner restarts.	Flame loss during stabilisation or operating phase	<ul style="list-style-type: none"> ▪ Check gas supply (gas pressure and gas flow switch). ▪ Check balanced flue system for flue gas recirculation. ▪ Check ionisation electrode. ▪ Check distance to burner gauze assembly. ▪ Check electrode/burner gauze assembly for contamination.

Fault messages (cont.)

Displayed fault code	System characteristics	Cause	Measures
F.65	Burner in a fault state.	Flame signal is not present or insufficient at burner start.	<ul style="list-style-type: none"> ▪ Check gas supply (gas pressure and gas flow switch). ▪ Check gas solenoid valve. ▪ Check system for condensate backup. Check condensate drain. <p>Note <i>Prevent water damage. Detach fan unit before removing the burner.</i></p> <ul style="list-style-type: none"> ▪ Check ionisation electrode and connecting cable. ▪ Check ignition: Connecting cables to ignition module and ignition electrode. ▪ Check distance from ignition electrode to burner gauze assembly. ▪ Check the electrode/burner gauze assembly for dirt. ▪ Check ignition electrode for broken insulation.
F.67	Burner in a fault state.	Ionisation current outside the permissible range.	<p>Check gas supply (gas pressure and gas flow switch), check gas solenoid valve and inlet strainer.</p> <p>Check ionisation electrode for the following:</p> <ul style="list-style-type: none"> ▪ Clearance to burner gauze assembly ▪ Check electrode/burner gauze assembly for contamination. <p>If specified measures don't help, replace fan unit. Reset the appliance.</p>
F.68	Burner in a fault state.	Flame signal is already present at burner start.	<p>Close the gas shut-off valve. Remove connecting cable of the ionisation electrode. Reset the appliance.</p> <p>If the fault persists, replace the BCU burner control unit.</p>



Fault messages (cont.)

Displayed fault code	System characteristics	Cause	Measures
F.69	Normal operation Fault is entered in fault history.	Ionisation current outside the permissible range.	Check ionisation electrode for the following: <ul style="list-style-type: none"> ▪ Check whether insulation block is touching electrode ceramic. ▪ Check gas solenoid valve: Activate "Minimum heating output" for approx. 4 min in actuator test. If this causes a fault to occur, replace BCU burner control unit. ▪ In the actuator test, switch from "Minimum heating output" to "Maximum heating output". If this fault occurs during modulation, check the intake screen for contamination. Replace the fan unit if necessary.
F.70	Burner in a fault state.	Internal error, burner control unit.	Replace the BCU burner control unit.
F.71	Burner in a fault state.	Fan speed too low.	<ul style="list-style-type: none"> ▪ Check fan for blockage. ▪ Check setting for gas type and flue system. Reset the appliance.
F.72	Burner in a fault state.	Fan idle state not reached.	Reset the appliance. If fault occurs repeatedly, replace fan unit.
F.73	Burner in a fault state.	Internal communication error.	Reset the appliance. If the fault recurs, replace the BCU burner control unit.
F.74	Burner locked out. Internal circulation pump off. No central heating and no DHW heating.	System pressure too low	Top up with water. Vent the system. If the fault occurs repeatedly: <ul style="list-style-type: none"> ▪ Check system pressure sensor with external pressure gauge. ▪ Check diaphragm expansion vessel pre-charge pressure. ▪ Check settings for set system pressure and range.
F.75	Burner in a fault state. Internal circulation pump off. No central heating and no DHW heating.	No flow rate	Open BDF valves. Top up with water. If the fault occurs repeatedly: <ul style="list-style-type: none"> ▪ Replace the flow sensor (if installed). ▪ Check pump. Replace if necessary.
F.77	Burner in a fault state.	Data memory burner control unit.	Reset the appliance. If the fault recurs, replace the BCU burner control unit.
F.78	Normal operation	Communication between heat management unit and programming unit faulty.	Check cables and plug-in connections between heat management unit and programming unit. Check cables for correct routing and positioning.

Fault messages (cont.)

Displayed fault code	System characteristics	Cause	Measures
F.80	Normal operation	Short circuit, analogue sensor input 2 on ADIO.	Check/replace sensor.
F.87	Burner in a fault state.	Water pressure too high.	Open BDF valves. Check expansion vessel function. Correct the amount of water in the system. Replace water pressure sensor. Replace safety assembly.
F.89	No central heating and no DHW heating. Internal pump not functioning.	Internal circulation pump blocked.	Check circulation pump. Replace if necessary.
F.91	Function of affected extension in emergency mode.	DIO electronics module communication error.	Check connections on DIO electronics module and connection to heat management unit.
F.92	Function of the relevant electronics module in emergency mode.	ADIO electronics module communication error.	<ul style="list-style-type: none"> ▪ Check setting in the commissioning assistant and correct if required. ▪ Check connections and leads to the ADIO electronics module. ▪ Check PlusBus voltage level (24 to 28 V). ▪ Check subscriber number on rotary switch S1 and correct if required.
F.93	Function of affected extension in emergency mode.	M2IO electronics module communication error.	Check connections on M2IO electronics module and connection to HMU heat management unit.
F.94	Function of the relevant electronics module in emergency mode. No solar central heating backup.	SDIO electronics module communication error.	<ul style="list-style-type: none"> ▪ Check setting in the commissioning assistant and correct if required. ▪ Check connections and leads to the SDIO electronics module. ▪ Check PlusBus voltage level (24 to 28 V).
F.100	Electronics modules connected to PlusBus not working.	Voltage error PlusBus.	Check whether the PlusBus power supply on the HMU heat management unit is OK: Remove all connected PlusBus components and reconnect one by one. Check that there aren't more than 2 Vitotrol 200-E connected to the HMU. Check whether there is a short circuit at the PlusBus cable.
F.104	Depending on configuration of EM-EA1 extension (DIO electronics module). If "block system" is configured, the burner switches/ remains off. If "fault message output" is configured, the fault message output is switched on.	External fault message input active.	Check connected external device.



Fault messages (cont.)

Displayed fault code	System characteristics	Cause	Measures
F.142	Burner in a fault state.	Communication error, CAN bus.	<ul style="list-style-type: none"> ▪ Check the fan unit for correct function. For this, check the step-per motor of the fan unit (reference run with mains ON). ▪ If the fault still persists, visually check the plug-in connections and cables of the CAN bus. ▪ Check further CAN bus subscribers. If fault still persists, replace the fan unit.
F.160	Burner in a fault state.	Communication error, CAN bus.	<ul style="list-style-type: none"> ▪ If "Connection error" is displayed, check the internal CAN bus subscriber connections. ▪ If only F.160 is displayed, check the connections of the external CAN bus subscribers. ▪ Check the connecting cables for secure seating and corrosion. Reset the appliance.
F.161	Burner in a fault state.	BCU data memory access error.	Reset the appliance. If the fault recurs, replace the BCU burner control unit.
F.162	Burner in a fault state.	Processor low voltage.	Turn the appliance off and on again. Check the connecting cable. Reset the appliance.
F.163	Burner in a fault state.	Memory access checksum error BCU.	Reset the appliance. If the fault recurs, replace the BCU burner control unit.
F.180	Burner in a fault state.	Gas pressure too low.	Check gas pressure. Inform the gas supplier if necessary. If the fault occurs repeatedly: Check the gas pressure switch and replace the gas valve if necessary. Direct replacement of the gas pressure switch is not permissible!
F.182	No DHW heating.	Short circuit, outlet temperature sensor (if installed).	Check outlet temperature sensor (plug X1, wires 13 and 14). Measure sensor input on electronics module. Setpoint: 3.3 V _{DC} with sensor disconnected.
F.183	No DHW heating.	Lead break, outlet temperature sensor (if installed).	Check outlet temperature sensor (plug X1, wires 13 and 14).
F.184	Burner in a fault state.	Short circuit, flow temperature sensor/high limit safety cut-out.	Check the flow temperature sensor/high limit safety cut-out. Check sensor lead. Replace faulty component if required. Reset the appliance.
F.185	Burner in a fault state.	Lead break, flow temperature sensor/high limit safety cut-out.	Check the flow temperature sensor/high limit safety cut-out. Replace faulty component if required. Reset the appliance.

Fault messages (cont.)

Displayed fault code	System characteristics	Cause	Measures
F.299	Time/date incorrect.	Real time clock setting incorrect.	Set the time and date.
F.342	No central heating, no DHW heating.	Communication error, BCU burner control unit.	<ul style="list-style-type: none"> ▪ Check connecting cable to the burner control unit plug X4 on BCU. ▪ Check all plug-in connections and cables of the internal CAN. ▪ Remove all plugs except X4, X2, X16 and X18 from the BCU burner control unit. Check whether fault persists. <p>Note <i>Several other fault messages will be added due to the removed plugs. Ignore these. If fault message F.342 is no longer shown, re-insert the plugs one by one and establish which component is faulty.</i></p> Reset the appliance.
F.345	Burner locked out, automatic enabling after appliance cool-down. Independent restart.	Temperature limiter has responded. See heat generator specification.	<ul style="list-style-type: none"> ▪ Ensure adequate heat transfer. ▪ Check heating system fill level. ▪ Check pre-charge pressure in diaphragm expansion vessel. Adjust to required system pressure. ▪ Check whether flow rate is sufficient (flow sensor and pump). ▪ Check 3-way diverter valve function in actuator test. Vent the system. If the fault occurs during DHW heating: Check DHW cylinder or plate heat exchanger for contamination and scaling.
F.346	Burner in a fault state.	Ionisation current calibration error.	<ul style="list-style-type: none"> ▪ Check the gas supply pressure. ▪ Check gas solenoid valve strainer on the inlet side for contamination. ▪ Check ionisation electrode for contamination. ▪ Check flue system. Remove flue gas recirculation if required. ▪ Check the connecting cable to the fan unit. ▪ Check impeller for ease of operation. Reset the appliance.

Fault messages (cont.)

Displayed fault code	System characteristics	Cause	Measures
F.348	Burner in a fault state.	Gas modulation valve calibration failed.	If several heat generators are connected to a common flue system: Check whether " Multiple connections " is set in the commissioning assistant. Check the flue system for unrestricted flow. If fault remains, replace gas fan unit.
F.349	Burner in a fault state.	Air mass rate flow not detected correctly in fan unit.	<ul style="list-style-type: none"> ▪ Check for dust contamination in the supply air. ▪ Check burner gauze assembly for contamination. Reset the appliance. If the fault occurs repeatedly, replace the gas fan unit.
F.350, F.351	Burner in a fault state.	Ionisation current outside the permissible range.	Replace BCU burner control unit.
F.352	Burner in a fault state.	CO limit within appliance exceeded.	Check entire flue gas path for the following: <ul style="list-style-type: none"> ▪ Flue gas recirculation ▪ Leaks ▪ Flue gas back pressure caused by water pocket (if flue system fall is insufficient) ▪ Constrictions ▪ Blockages Repair flue system if necessary. Reset the appliance.
F.353	Burner shutdown with restart if demand exists.	Insufficient gas supply, burner output reduced.	Check the gas supply. Optically check input-side screen in the gas solenoid valve for contamination. Reset the appliance.
F.354	Burner in a fault state.	Gas modulation valve tolerance outside permissible range.	Replace gas fan unit.
F.355	Burner in a fault state.	Condensate backed up or analogue signal reference check: Flame signal is already present at burner start. Function of ignition transformer.	If condensate is backed up: Replace insulation blocks, electrodes and burner gauze assembly. Note <i>Remove the fan unit before opening the burner. Protect the PCB from water damage.</i> Replace the BCU burner control unit. Check ignition transformer and ignition cable. Replace if necessary.

Fault messages (cont.)

Displayed fault code	System characteristics	Cause	Measures
F.357	Burner in a fault state.	Insufficient gas supply.	<ul style="list-style-type: none"> ▪ Check that the gas shut-off valve is open. ▪ Optically check input-side screen in the gas solenoid valve for contamination. ▪ Test static gas pressure and gas flow pressure. ▪ Check that on-site gas line and gas flow switch are correctly sized. <p>Note <i>If the building pressure regulator has a leak, you may notice rising pressure when the burner is idle. When the system is restarted, the gas flow switch may trip. If the static pressure does not drop, check the cable to the fan unit. Check that the coil resistance at the fuel valve is approx. 4 kΩ. Check the ignition electrode for damaged insulation.</i></p> <p>Reset the appliance.</p>
F.359	Burner in a fault state.	No ignition spark.	<ul style="list-style-type: none"> ▪ Check whether the ignition electrode insulation is damaged. ▪ Check whether 230 V~ is present at the ignition module during the ignition phase. If not, replace the BCU burner control unit. ▪ If 230 V~ is present at the ignition module input but there is still a fault, replace the ignition module. ▪ Check connection cables and leads from ignition module and ignition electrode. <p>Reset the appliance.</p>
F.361	Burner in a fault state.	Flame signal is not present or insufficient at burner start.	<p>Check ionisation electrode and connecting cable. Check plug-in connections for loose contacts.</p> <p>Note <i>Deposits on the electrodes indicate foreign bodies in the combustion air. Check the installation room and flue system for causes of the deposits. For example laundry detergents, cleaning agents, toiletries, deposits in the ventilation air supply (chimney).</i></p> <p>Reset the appliance.</p>
F.365, F.366, F.367	Burner in a fault state.	Gas valve electricity supply does not turn off.	<p>Replace BCU burner control unit.</p>



Fault messages (cont.)

Displayed fault code	System characteristics	Cause	Measures
F.368	Burner in a fault state.	Gas pressure switch fault. Forced ventilation time expired.	Check gas supply (gas pressure). Check gas pressure switch (if installed). If necessary, disconnect the gas pressure switch connector and check whether the burner starts. Reset the appliance.
F.369	Burner in a fault state.	Flame loss immediately after flame formation (during safety time).	Check gas supply (gas pressure and gas flow switch). Check balanced flue system for flue gas recirculation. Check ionisation electrode for the following: <ul style="list-style-type: none"> ▪ Clearance to burner gauze assembly. ▪ Contamination on electrode. Reset the appliance.
F.370	Burner in a fault state.	Fuel valve or modulation valve will not close.	Reset the appliance. If fault occurs repeatedly, replace fan unit.
F.371	Burner in a fault state.	Fan speed too low.	<ul style="list-style-type: none"> ▪ Check the fan. ▪ Check the fan connecting cables. ▪ Check the fan power supply. Reset the appliance.
F.372	Burner in a fault state.	Repeated flame loss during calibration.	<ul style="list-style-type: none"> ▪ Check ionisation electrode and connecting cable. ▪ Check plug-in connections for loose contacts. ▪ Check flue system. Remove flue gas recirculation if required. ▪ Check system for condensate backup. ▪ Visually inspect gas solenoid valve inlet and strainer on the inlet side for contamination. <p>Note <i>To prevent water damage, detach fan unit before removing the burner. Deposits on the electrodes indicate foreign bodies in the combustion air.</i></p> <p>Check the installation room and flue system for causes of the deposits. For example laundry detergents, cleaning agents, toiletries, deposits in the ventilation air supply (chimney). If burner gauze assembly and ionisation electrode have been replaced, also clean fan unit, gas/air channel and Venturi extension. Reset the appliance.</p>

Fault messages (cont.)

Displayed fault code	System characteristics	Cause	Measures
F.373	Burner in a fault state.	Heat transfer too low during calibration. Temperature limiter has shut down.	<ul style="list-style-type: none"> ▪ Ensure adequate heat transfer. ▪ Check circulation pump for faults, scale or blockages. ▪ Check 3-way diverter valve function in actuator test. Vent the system. ▪ Check function of flow sensor. Reset the appliance.
F.375	Burner in a fault state.	Ionisation current calibration error.	<ul style="list-style-type: none"> ▪ Check gas flow pressure. ▪ Check gas solenoid valve inlet strainer for dirt. ▪ Check ionisation electrode for contamination. ▪ Check flue system; remove flue gas recirculation if required. Reset the appliance.
F.377	Burner in a fault state.	Post-processing of ionisation current calibration: Stabilisation conditions for post-calibration not met.	Check gas type setting. If fault recurs, replace BCU burner control unit. Reset the appliance.
F.378	Burner in a fault state.	Flame loss in the stabilisation or operating phase.	<ul style="list-style-type: none"> ▪ Check gas supply (gas pressure and gas flow switch). ▪ Check flue gas recirculation. ▪ Check for contamination of ionisation electrode and burner gauze assembly. Reset the appliance.
F.379	Burner in a fault state.	Flame signal not present or insufficient.	<ul style="list-style-type: none"> ▪ Check ionisation electrode connecting cable for damage and ensure it is secure. ▪ Check ionisation electrode. Replace if necessary. Reset the appliance.
F.380	Burner in a fault state.	Flame loss immediately after flame formation (during safety time).	Check gas supply (gas pressure and gas flow switch). Check balanced flue system for flue gas recirculation. Check ionisation electrode, burner gauze assembly: <ul style="list-style-type: none"> ▪ Clearance to burner gauze assembly ▪ Contamination on electrode Reset the appliance.

Fault messages (cont.)

Displayed fault code	System characteristics	Cause	Measures
F.381	Burner in a fault state.	Flame loss during operating phase.	Check gas supply (gas pressure and gas flow switch). Check balanced flue system for flue gas recirculation. Check ionisation electrode, burner gauze assembly: <ul style="list-style-type: none"> ▪ Clearance to burner gauze assembly. ▪ Contamination on electrode Reset the appliance.
F.382	Burner in a fault state.	Fault counter has exceeded limit.	Reset the appliance. Work through fault analysis using fault history.
F.383	Burner in a fault state.	Possible contamination of gas line.	<ul style="list-style-type: none"> ▪ Check gas line for contamination. ▪ Check the gas supply pressure. ▪ Replace gas fan if required. Reset the appliance.
F.384	Burner in a fault state.	Possible contamination of gas line.	<ul style="list-style-type: none"> ▪ Check gas line for contamination. ▪ Check the gas supply pressure. ▪ Replace gas fan if required. Reset the appliance.
F.385	Burner in a fault state.	Short circuit, signal 1, ionisation current. BCU burner control unit faulty.	Check IO electrode for earth fault. If the fault persists, replace the BCU burner control unit. Reset the appliance.
F.386	Burner in a fault state.	BCU burner control unit faulty.	Replace the BCU burner control unit. Reset the appliance.
F.387	Burner in a fault state.	Earth fault, ionisation current. BCU burner control unit faulty.	Check ionisation electrode and connecting cable. If the fault persists, replace the BCU burner control unit. Reset the appliance.
F.388	Burner in a fault state.	BCU burner control unit faulty.	Replace the BCU burner control unit. Reset the appliance.
F.394	Burner in a fault state.	Lead break, flue gas temperature sensor 2.	Check sensor and connecting cable. Replace sensor if necessary. Reset the appliance.
F.395	Burner in a fault state.	IO electrode earth fault, BCU burner control unit faulty.	Check ignition electrode for earth fault. If the fault persists, replace the BCU burner control unit. Reset the appliance.
F.396	Burner in a fault state.	BCU burner control unit faulty.	Replace the BCU burner control unit. Reset the appliance.
F.399	Burner in a fault state.	IO electrode earth fault, BCU burner control unit faulty.	Check IO electrode for earth fault. If the fault persists, replace the BCU burner control unit. Reset the appliance.
F.400	Burner in a fault state.	BCU burner control unit faulty.	Replace the BCU burner control unit. Reset the appliance.

Fault messages (cont.)

Displayed fault code	System characteristics	Cause	Measures
F.401	Burner in a fault state.	IO electrode earth fault, BCU burner control unit faulty.	Check IO electrode for earth fault. If the fault persists, replace the BCU burner control unit. Reset the appliance.
F.402	Burner in a fault state.	BCU burner control unit faulty.	Replace the BCU burner control unit. Reset the appliance.
F.403	Burner in a fault state.	Ionisation electrode earth fault, BCU burner control unit faulty.	Check IO electrode for earth fault. If the fault persists, replace the BCU burner control unit. Reset the appliance.
F.404	Burner in a fault state.	BCU burner control unit faulty.	Replace the BCU burner control unit. Reset the appliance.
F.405	Burner in a fault state.	Ionisation electrode earth fault, BCU burner control unit faulty.	Check IO electrode for earth fault. If the fault persists, replace the BCU burner control unit. Reset the appliance.
F.406, F.408, F.410	Burner in a fault state.	BCU burner control unit faulty.	Replace the BCU burner control unit. Reset the appliance.
F.416	Burner locked out.	Flue gas temperature sensor incorrectly positioned.	Install flue gas temperature sensor correctly: See "Repairs". Carry out mains reset after fault has been remedied.
F.417, F.418	Burner in a fault state.	BCU burner control unit faulty.	Replace the BCU burner control unit. Reset the appliance.
F.425	System in normal operation, calculation out of operation.	Time synchronisation failed.	Set the time. If external time is used, check parameters 1504 and 508.
F.430	Normal operation in line with set values of heat generator.	Communication error gateway.	Check gateway module connecting cable and power supply.
F.431	Normal operation in line with set values of heat generator.	Communication error KNX gateway.	Check gateway module connecting cable and power supply.
F.436	Normal operation	Short circuit, flow sensor.	Check flow sensor.
F.437	Flow rate not being monitored. System continues operating in normal mode with replacement value.	Lead break or short circuit, flow sensor.	Check connecting cable between BCU and flow sensor. Check voltage level to see if 5 V is present. Turn the ON/OFF switch on the gas condensing boiler off and back on again.
F.446	Burner in a fault state.	Deviation, heat generator flow temperature sensor/ high limit safety cut-out	Check the flow temperature sensor/high limit safety cut-out. Check plug-in connection and lead to sensor. Reset the appliance.
F.447, F.448	Burner in a fault state.	Deviation, ionisation voltage signal.	Replace the BCU burner control unit. Reset the appliance.
F.449, F.450, F.451, F.452	Burner in a fault state.	Error in scheduled program run monitoring.	Reset the appliance. If the fault recurs, replace the BCU burner control unit.

Fault messages (cont.)

Displayed fault code	System characteristics	Cause	Measures
F.453	Burner in a fault state.	Synchronisation error, sequence.	Reset the appliance. If the fault recurs, replace the BCU burner control unit.
F.454	Burner in a fault state.	Incorrect software version, BCU.	Flash the correct software version for the BCU burner control unit.
F.455	Burner in a fault state.	Error in program run monitoring.	Reset the appliance. If the fault recurs, replace the BCU burner control unit.
F.456	Burner in a fault state.	Error in program run monitoring.	Reset the appliance. If the fault recurs, replace the BCU burner control unit.
F.457	Burner in a fault state.	Fan sluggish or blocked.	Reset the appliance. Check fan for sluggishness. In the case of severe contamination or grinding noises, replace fan unit.
F.458	Burner in a fault state.	Incorrect reset sequence.	Check connections between HMU heat management unit and HMI programming unit. Reset the appliance.
F.463	Burner in a fault state.	Contaminated combustion air, flue gas recirculation.	Check flue system for contamination and flue gas recirculation. Clean flue system if required. Reset the burner. Note <i>Deposits on the electrodes indicate foreign bodies in the combustion air. Check the installation room and flue system for causes of the deposits. For example laundry detergents, cleaning agents, toiletries, deposits in the ventilation air supply (chimney). If burner gauze assembly and ionisation electrode have been replaced, also clean fan unit, gas/air channel and Venturi extension. Reset the appliance.</i>

Fault messages (cont.)

Displayed fault code	System characteristics	Cause	Measures
F.464	Burner in a fault state.	Ionisation current too low during calibration. Differential compared to previous value not plausible.	<ul style="list-style-type: none"> ▪ Check ionisation electrode and connecting cable. Check plug-in connections for loose contacts. ▪ Check whether there is a lot of dust in the ventilation air (e.g. from construction work). ▪ Check flue system. Remove flue gas recirculation if required. ▪ Check system for condensate backup. <p>Reset the appliance.</p> <p>Note <i>To prevent water damage, detach fan unit before removing the burner.</i></p> <p>If the fault is permanently present, replace the BCU burner control unit.</p> <p>Note <i>Deposits on the electrodes indicate foreign bodies in the combustion air. Check the installation room and flue system for causes of the deposits. For example laundry detergents, cleaning agents, toiletries, deposits in the ventilation air supply (chimney). If burner gauze assembly and ionisation electrode have been replaced, also clean fan unit, gas/air channel and Venturi extension.</i></p>
F.467	Burner in a fault state.	Gas supply insufficient during calibration Contaminated or insufficiently sized gas line.	<ul style="list-style-type: none"> ▪ Test static gas pressure and gas flow pressure. ▪ Check that on-site gas line and gas flow switch are correctly sized. ▪ Visually inspect gas solenoid valve inlet and strainer on the inlet side for contamination. <p>Reset the appliance.</p> <p>Note <i>Contamination, for example from a brazed gas line, can block up the inlet strainer of the gas solenoid valve.</i></p>



Fault messages (cont.)

Displayed fault code	System characteristics	Cause	Measures
F.468	Burner in a fault state.	Ionisation current too high during calibration.	<p>Check gap between ionisation electrode and burner gauze assembly.</p> <p>Check whether there is a lot of dust in the ventilation air (e.g. from construction work).</p> <p>Reset the appliance.</p> <p>Note <i>Deposits on the electrodes indicate foreign bodies in the ventilation air. Check the installation room and flue system for causes of the deposits. For example laundry detergents, cleaning agents, toiletries, deposits in the ventilation air supply (chimney). If burner gauze assembly and ionisation electrode have been replaced, also clean fan unit, gas/air channel and Venturi extension.</i></p>
F.471	No heat demand.	System pressure sensor not available, lead break or short circuit.	<ul style="list-style-type: none"> ▪ Check system pressure sensor (plug [163]). ▪ Check lead and plug-in connection. ▪ Check whether the supply voltage to the sensor is 5 V$\overline{=}$.
F.473	No heat demand.	HMU heat management unit communication error.	Check connecting cable between burner control unit and HMU heat management unit.
F.474	Burner in a fault state.	Error in scheduled program run monitoring.	Reset the appliance. If the fault recurs, replace the BCU burner control unit.
F.477	Limited solar thermal system functionality. No solar yield.	Fault, differential temperature monitor solar collector/cylinder differential exceeds tolerance. Air in the solar circuit. Sensor not positioned correctly. Pump faulty.	<p>Check solar circuit, solar circuit pump, sensors.</p> <p>Note <i>Fault can be reset by performing a network reset. If the system is OK, the fault is cleared automatically after 36 hours.</i></p>
F.517	Remote control not functioning. Weather-compensated operation: Normal operation. Constant operation: Weather-compensated operation.	Lead break, PlusBus cable, incorrect appliance address set, remote control faulty.	<ul style="list-style-type: none"> ▪ Check commissioning assistant setting. ▪ Check remote control cable. ▪ Check remote control subscriber number. Replace faulty remote control if necessary.
F.527	Burner in a fault state.	Incorrect parameter set, HMU heat management unit.	Overwrite (flash) the HMU heat management unit with the correct parameter set.
F.528	Burner in a fault state.	Incorrect parameter set, BCU burner control unit.	Overwrite (flash) the BCU burner control unit with the correct parameter set.

Fault messages (cont.)

Displayed fault code	System characteristics	Cause	Measures
F.530	Solar function limited.	Sensor value not available or lead break of one or more sensors/missing sensor(s).	Check sensor(s), or connect missing sensor(s) to SDIO electronics module.
F.538	No solar central heating backup with SDIO.	Lead break, temperature sensor in system return.	Check sensor or connect missing sensor on the SDIO electronics module.
F.539	No solar central heating backup with SDIO.	Short circuit, temperature sensor in system return.	Check sensor or connect missing sensor on the SDIO electronics module.
F.540	Burner in a fault state.	Condensate backup in the heat cell.	<ul style="list-style-type: none"> ▪ Check system for condensate backup. ▪ Check the condensate drain and trap. ▪ Replace insulation blocks, electrodes and burner gauze assembly if required. <p>Note To prevent water damage, detach fan unit before removing the burner.</p> <p>Reset the appliance.</p>
F.544	Mixer closes. Heating circuit pump is operational.	Lead break, flow temperature sensor, heating circuit 2 with mixer. Incorrect setting during commissioning.	<ul style="list-style-type: none"> ▪ Check flow temperature sensor, mixer 2. ▪ Measure voltage at sensor input on electronics module. Setpoint: 3.3 V_{DC} with sensor disconnected ▪ Check commissioning assistant setting. ▪ Check setting of ADIO rotary switch.
F.545	Mixer closes. Heating circuit pump is operational.	Short circuit, flow temperature sensor, heating circuit 2 with mixer.	<p>Check flow temperature sensor, mixer 2.</p> <p>Measure voltage at sensor input on electronics module. Setpoint: 3.3 V_{DC} with sensor disconnected</p>
F.546	Mixer closes. Heating circuit pump is operational.	Lead break, flow temperature sensor, heating circuit 3 with mixer	<ul style="list-style-type: none"> ▪ Check flow temperature sensor, mixer 3. ▪ Measure voltage at sensor input on electronics module. Setpoint: 3.3 V_{DC} with sensor disconnected ▪ Check commissioning assistant setting. ▪ Check setting of ADIO rotary switch.
F.547	Mixer closes. Heating circuit pump is operational.	Short circuit, flow temperature sensor, heating circuit 3 with mixer.	<p>Check flow temperature sensor, mixer 3.</p> <p>Measure voltage at sensor input on electronics module. Setpoint: 3.3 V_{DC} with sensor disconnected</p>



Fault messages (cont.)

Displayed fault code	System characteristics	Cause	Measures
F.548	Mixer closes. Heating circuit pump is operational.	Short circuit, flow temperature sensor, heating circuit 4 with mixer	<ul style="list-style-type: none"> ▪ Check flow temperature sensor, mixer 4. ▪ Measure voltage at sensor input on electronics module. Setpoint: 3.3 V_{DC} with sensor disconnected ▪ Check commissioning assistant setting. ▪ Check setting of ADIO rotary switch.
F.549	Mixer closes. Heating circuit pump is operational.	Short circuit, flow temperature sensor, heating circuit 4 with mixer.	Check flow temperature sensor, mixer 4. Measure voltage at sensor input on electronics module. Setpoint: 3.3 V _{DC} with sensor disconnected
F.574	Normal operation without room influence.	Room temperature sensor in heating circuit 1 not available.	Check external room temperature sensor in heating circuit or room temperature sensor for remote control unit. Check setting of parameter 933.6.
F.575	Normal operation without room influence.	Lead break, room temperature sensor, heating circuit 1.	Check external room temperature sensor in heating circuit or room temperature sensor for remote control unit.
F.576	Normal operation without room influence.	Short circuit, room temperature sensor, heating circuit 1.	Check external room temperature sensor in heating circuit or room temperature sensor for remote control unit.
F.577	Normal operation without room influence.	Room temperature sensor in heating circuit 2 not available.	Check external room temperature sensor in heating circuit or room temperature sensor for remote control unit. Check setting of parameter 934.6.
F.578	Normal operation without room influence.	Lead break, room temperature sensor, heating circuit 2.	Check external room temperature sensor in heating circuit or room temperature sensor for remote control unit.
F.579	Normal operation without room influence.	Short circuit, room temperature sensor, heating circuit 2.	Check external room temperature sensor in heating circuit or room temperature sensor for remote control unit.
F.580	Normal operation without room influence.	Room temperature sensor, heating circuit 3 not available.	Check external room temperature sensor in heating circuit or room temperature sensor for remote control unit. Check setting of parameter 935.6.
F.581	Normal operation without room influence.	Lead break, room temperature sensor in heating circuit 3.	Check external room temperature sensor in heating circuit or room temperature sensor for remote control unit.
F.582	Normal operation without room influence.	Short circuit, room temperature sensor in heating circuit 3.	Check external room temperature sensor in heating circuit or room temperature sensor for remote control unit.

Fault messages (cont.)

Displayed fault code	System characteristics	Cause	Measures
F.583	Normal operation without room influence.	Room temperature sensor in heating circuit 4 not available.	Check external room temperature sensor in heating circuit or room temperature sensor for remote control unit. Check setting of parameter 936.6.
F.584	Normal operation without room influence.	Lead break, room temperature sensor, heating circuit 4.	Check external room temperature sensor in heating circuit or room temperature sensor for remote control unit.
F.585	Normal operation without room influence.	Short circuit, room temperature sensor, heating circuit 4.	Check external room temperature sensor in heating circuit or room temperature sensor for remote control unit.
F.666	No solar function with pre-heating active. Second cylinder and solar transfer pump not working.	Lead break, DHW pre-heating sensor TS3.	Check temperature sensor TS3.
F.667	No solar function with pre-heating active. 2nd DHW cylinder and solar transfer pump not working.	Short circuit, sensor for DHW preheating TS3.	Check temperature sensor TS3.
F.668	No solar function with pre-heating active. 2nd DHW cylinder and solar transfer pump not working.	Lead break, DHW reheating sensor TS4.	Check temperature sensor TS4.
F.669	No solar function with pre-heating active. Second cylinder and solar transfer pump not working.	Short circuit, DHW pre-heating sensor TS4.	Check temperature sensor TS4.
F.670	No solar central heating backup.	Lead break, buffer temperature sensor TS3.	Check temperature sensor TS3.
F.671	No solar central heating backup.	Short circuit, buffer temperature sensor TS3.	Check temperature sensor TS3.
F.672	No solar function with thermostat function and solar transfer pump not working.	Lead break, thermostat function temperature sensor TS3.	Check temperature sensor TS3.
F.673	No solar function with thermostat function and solar transfer pump not working.	Short circuit, thermostat function temperature sensor TS3.	Check temperature sensor TS3.
F.682	Burner in a fault state.	Air mass flow rate sensor not available.	Check air mass flow rate sensor.
F.683	Burner in a fault state.	Air mass flow rate sensor faulty.	Check air mass flow rate sensor.
F.684	Burner in a fault state.	Back draught safety device faulty.	Check back draught safety device.
F.688	MZIO electronics module in emergency mode.	MZIO electronics module communication error.	Check setting in the commissioning assistant and correct if required. Check connections and leads to the MZIO electronics module. Check PlusBus voltage level (24 to 28 V).

Fault messages (cont.)

Displayed fault code	System characteristics	Cause	Measures
F.693	Burner in a fault state.	Lead break, flue gas temperature sensor.	Check flue gas temperature sensor. Reset the appliance.
F.694	Burner in a fault state.	Signal comparison, deviation, flue gas high limit safety cut-out.	<ul style="list-style-type: none"> ▪ Check plug-in connection and sensor lead. ▪ Check sensor. Replace sensor if required. ▪ Reset the appliance.
F.696	Burner in a fault state.	Short circuit, flue gas temperature sensor.	Check flue gas temperature sensor. Reset the appliance.
F.762	System in a fault state.	System pressure too low.	Top up with water. Vent the system. If the fault occurs repeatedly: Check the diaphragm expansion vessel.
F.763	System in a fault state.	Gas pressure too high.	Check gas pressure. Inform the gas supplier if necessary.
F.764	System in a fault state.	Lag appliance reports a fault.	Check lag appliance fault. Reset the appliance.
F.765	System in a fault state.	Lag appliance communication error.	Check lag appliance communication. Reset the appliance.
F.797	No DHW heating, no heating operation.	Mechanical fault, heating circuit pump.	Check pump, replace if required. Reset the appliance.
F.799	No DHW heating, no heating operation.	Central heating circuit pump reports an electrical fault. Heating system cannot be operated as no flow rate is available.	Switch appliance off and on again at the appliance switch. If this occurs repeatedly, replace the heating circuit pump.

Fault messages (cont.)

Displayed fault code	System characteristics	Cause	Measures
F.980	No DHW heating.	Minimum system pressure before the start of DHW heating is too low. Possible causes: <ul style="list-style-type: none"> ▪ Shut-off or too much constriction ▪ Scaling, sludge ▪ Incorrect hydraulic configuration ▪ Faulty circulation pump, air in the heating circuit ▪ Unstable or excessively low system pressure 	<ul style="list-style-type: none"> ▪ Check that the cylinder flow and return are open. ▪ Ensure that all quick-action air vent valves on the appliance side are permanently open. ▪ Restart the venting program of the heating circuit (selection via service menu). <p>Note <i>Quick-action air vent valves in the boiler circuit must be permanently open!</i></p> <ul style="list-style-type: none"> ▪ Check the set hydraulic scheme and correct if necessary. ▪ Check the size and pre-charge pressure of the external DEV (diaphragm expansion vessel). ▪ Check the set system pressure (this fault is more likely if the system pressure is too low). ▪ Check the quick-action air vent valves for leaks and replace if faulty. ▪ Check the pump and replace if faulty. ▪ Pause time for DHW heating can be terminated by a mains reset of the HMU. Switch the appliance off and on again at the appliance switch.



Fault messages (cont.)

Displayed fault code	System characteristics	Cause	Measures
F.981	No DHW heating.	Minimum system pressure is too low during DHW heating. Possible causes: <ul style="list-style-type: none"> ▪ Shut-off or too much constriction ▪ Scaling, sludge ▪ Incorrect hydraulic configuration ▪ Faulty circulation pump, air in the heating circuit ▪ Unstable or excessively low system pressure 	<ul style="list-style-type: none"> ▪ Restart the venting program of the heating circuit (selection via service menu). <p>Note <i>Quick-action air vent valves in the boiler circuit must be permanently open!</i></p> <ul style="list-style-type: none"> ▪ Check the set hydraulic scheme and correct if necessary. ▪ Check the size and pre-charge pressure of the external DEV (diaphragm expansion vessel). ▪ Check the set system pressure (this fault is more likely if the system pressure is too low). ▪ Check the quick-action air vent valves for leaks; replace if faulty. ▪ Check the pump and replace if faulty. ▪ Pause time for DHW heating can be terminated by a mains reset of the HMU. Switch the appliance off and on again at the appliance switch.
F.982	No DHW heating, no heating operation.	Heating circuit pump, heating circuit 1 running dry.	Check pump and diaphragm expansion vessel. Check water pressure.

Note

If subscriber faults occur, "**Fault, subscriber ...**" is displayed.

Further messages

Service messages

Message on the display	Meaning
P.1	Service due after interval.
P.4	Top up heating water.
P.8	Service due after burner hours run.

Status messages

Message on the display	Meaning
S.9	Fan pre-purge for heating mode
S.29	Standard mode for heating
S.36	Comfort mode for DHW draw-off
S.59	Flue gas temperature sensor test active
S.60	Summer mode active (outside temperature economy function)
S.74	Heating suppression, heating
S.75	DHW circulation pump active

Further messages (cont.)

Message on the display	Meaning
S.94	No demand, external hook-up, heating circuit 1
S.95	No demand, external hook-up, heating circuit 2
S.96	No demand, external hook-up, heating circuit 3
S.154	Due to insufficient heat transfer in heating system, burner operation not required

Warning messages

Messages on the display	Meaning	Measure
A.11	System pressure has fallen below normal limit.	Top up with water or notify heating contractor.
A.12	Real time clock battery flat.	Replace the battery (type CR2032) in the HMU heat management unit.
A.18	Possible condensate backup in the heat cell	Check combustion chamber and condensate drain. Condensate may escape when the burner door is removed. Take appropriate precautions to protect the electronic components. If there is condensate backup as far as the combustion chamber, replace the insulation ring, insulation block, insulation mats, ionisation electrode, ignition electrode, burner gauze assembly and burner gauze assembly gasket.
A.19	Temperature limiter has responded	
A.20	Service interval could not be activated.	Check the time and date settings.

Information

Message on the display	Meaning
I.56	External demand active
I.57	External blocking active
I.59	Parameters were restored (parameter set was flashed to BCU electronics module).
I.93	Can occur along with fault messages F.89, F.797, F.799. F.982, see chapter "Fault messages"

Repairs

! Please note

Residual water will escape when the boiler or one of the following components is fitted or removed:

- Water-filled pipework
- Heat exchanger
- Circulation pumps
- Plate heat exchanger
- Components fitted in the heating water or DHW circuit.

Water ingress can result in damage to other components.

Protect the following components against ingress of water:

- Control unit components (especially in the service position)
- Electrical components
- Plug-in connections
- Cables and leads

Shutting down the boiler

1. Turn off the power supply at the ON/OFF switch.
2. Shut off the gas supply.
3. If the boiler needs to be removed:
 - Isolate the system from the power supply, e.g. by removing the separate fuse or by means of a mains isolator, and check that it is no longer live.
 - Safeguard the system against reconnection.
 - Disconnect the balanced flue system.
 - Drain the boiler on the heating water and DHW sides.
 - Disconnect the on-site cables/leads.

Repairs (cont.)

Removing the boiler from the pre-plumbing jig or mounting frame

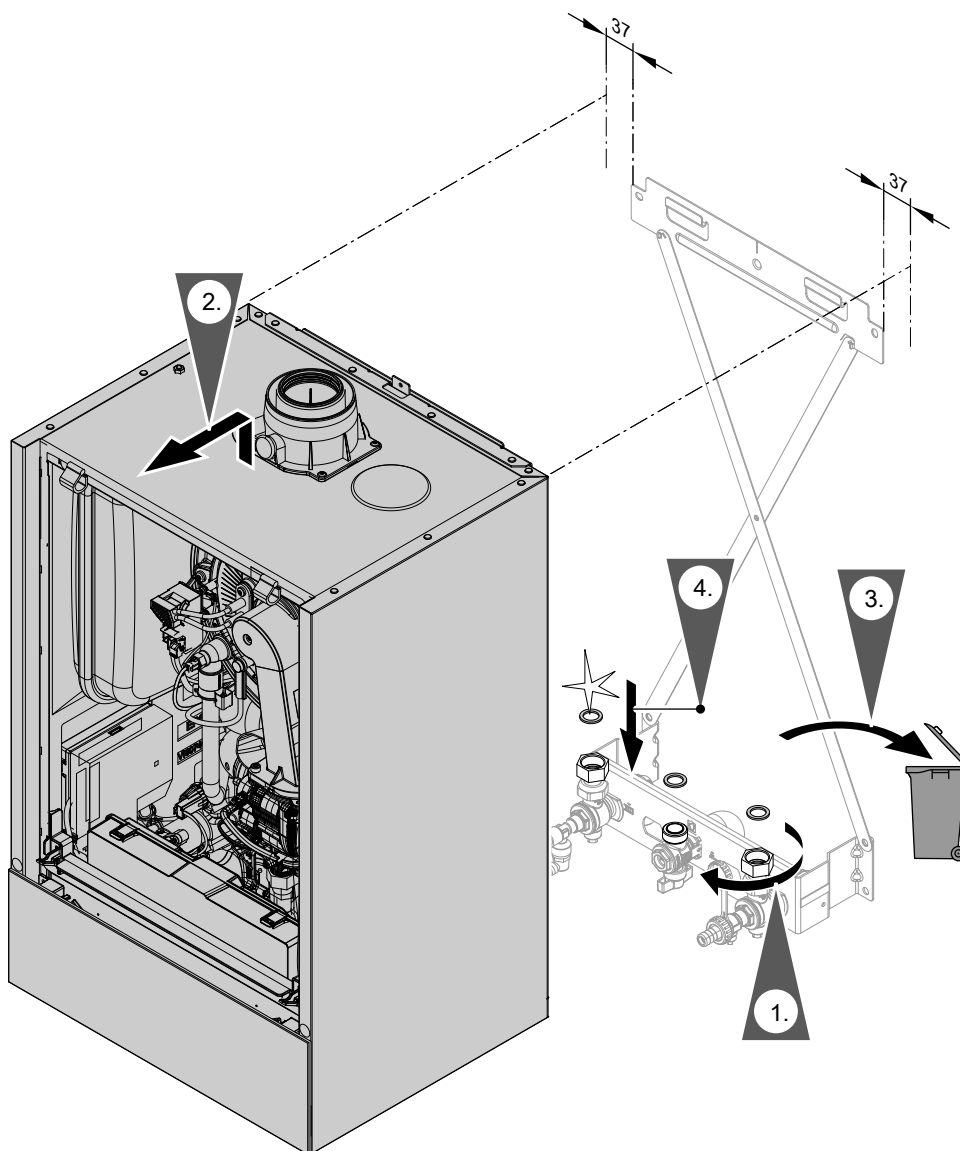

Fig. 53

Note

Use new gaskets and, if required, new locking ring connections when assembling.

Internal gasket diameter:

- Gas connection \varnothing 18.5 mm
- Connections on the heating water side \varnothing 17.0 mm

Gaskets and locking ring connections are available as spare parts (if required).

Note

When carrying out any work on gas connection fittings, counterhold with a suitable tool. Never transfer any forces to the internal components.



Danger

Escaping gas leads to a risk of explosion. Check all connections on the gas side (also inside the appliance) for tightness.

Status/checking/diagnosing the internal circulation pump

The internal circulation pump is fitted with two status LEDs.

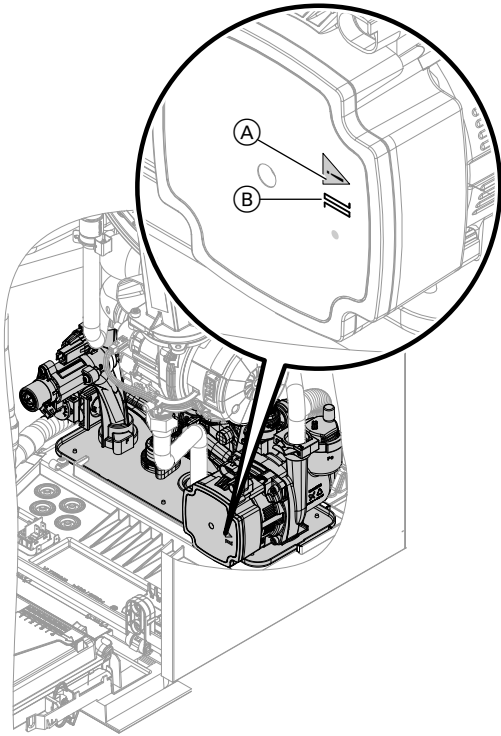

Fig. 54

- (B) LED constant green:
No communication (pump is running without external control from the boiler controller).
- (B) LED flashing green:
Pump is running with external control (PWM signal) from the boiler controller
- (A) LED constant red:
Pump failure

Note

The pump is controlled by a PWM signal. A lead break in the data line will not generate a fault message. The pump is operating at 100 % of its maximum output.

Checking the temperature sensors

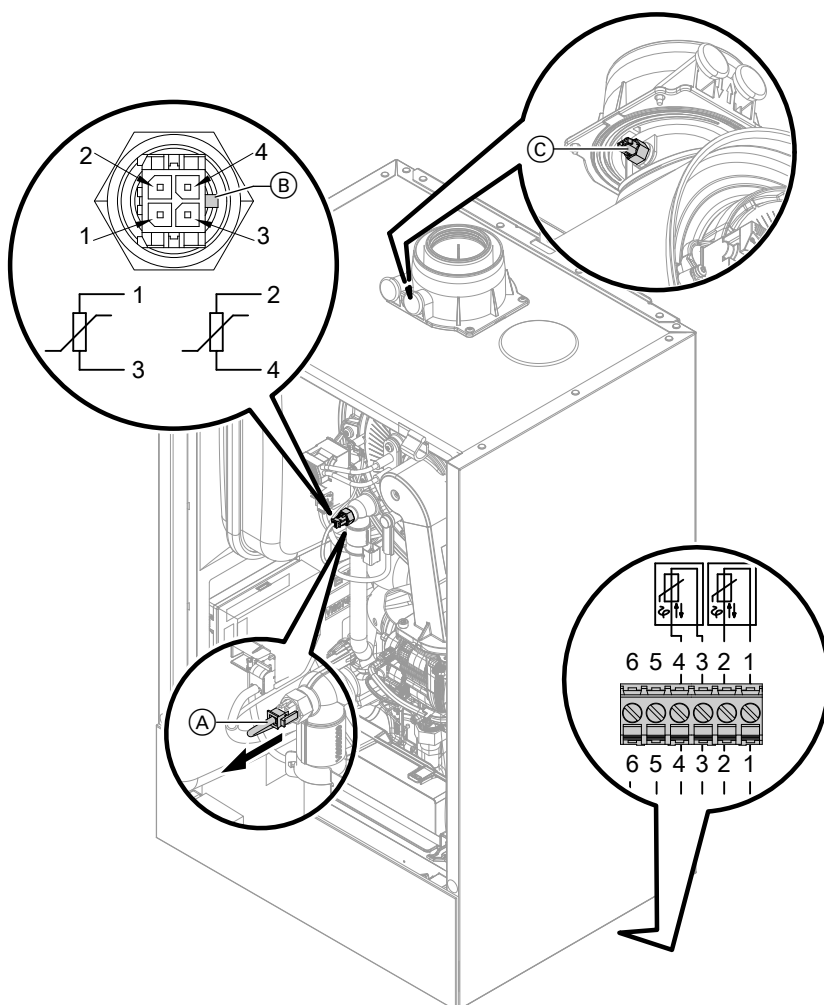

Fig. 55

Heat generator circuit flow temperature sensor (dual sensor)

1. Check the leads and plugs of flow temperature sensors (A).
2. Disconnect the leads from flow temperature sensors (A).

3. Check the sensor resistance. Note position of guide lug (B).
 - Sensor 1: Connections 1 and 3
 - Sensor 2: Connections 2 and 4



Compare the resistances with the value for the current temperature from the following diagram. In the event of severe deviation (> 10 %), replace the dual sensor.

Danger
 The dual sensor is directly immersed in the heating water (risk of scalding). Drain the boiler on the heating water side before replacing the sensor.

Danger
 Risk of electric shock from escaping heating water. Check the dual sensor for leaks.

Repairs (cont.)

Cylinder temperature sensor/outlet temperature sensor

1. Check lead and plug of cylinder temperature sensor  or outlet temperature sensor .
2. Disconnect wires of sensor plug.
3. Check the sensor resistance. Compare the resistance with the value for the current temperature from the following diagram.
In the event of severe deviation (> 10 %), replace the sensor.

Low loss header sensor

1. Check lead and plug of temperature sensor  on the ADIO electronics module (mixer extension kit).
2. Disconnect wires of sensor plug.
3. Check the sensor resistance. Compare the resistance with the value for the current temperature from the following diagram.
In the event of severe deviation (> 10 %), replace the sensor.

Outside temperature sensor



1. Check the lead and plug of the outside temperature sensor.
2. Disconnect wires 1 and 2 from the external plug.

Note

Depending on appliance version, on floorstanding compact appliances the plug is located inside the appliance.

3. Check the sensor resistance. Compare the resistance with the value for the current temperature from the following diagram.
If the results are very different from the curve (> 10 %), disconnect the wires from the sensor. Repeat the test directly on the sensor.
Check the on-site lead. 2-core lead, length up to 35 m with a cross-section of 1.5 mm²
Depending on the test result, replace the lead or the outside temperature sensor.

Flue gas temperature sensor

1. Check the lead and plug of flue gas temperature sensor .
2. Disconnect leads, flue gas temperature sensor .
3. Rotate sensor (anti-clockwise) by ¼ turn to remove it (bayonet fitting).
4. Check the sensor resistance. Compare the resistance with the value for the currently recorded temperature from the following diagram.
In the event of severe deviation (> 10 %), replace the sensor.
5. Rotate sensor (clockwise) by ¼ turn to install it.



Danger

Escaping flue gas can cause poisoning. When restarting, check for leaks on the flue gas side.

6. Reconnect leads, flue gas temperature sensor .
7. If the permissible flue gas temperature has been exceeded, the flue gas temperature sensor locks out the appliance. Reset the burner on the programming unit once the flue system has cooled down.

Repairs (cont.)

- Flue gas temperature sensor
- Flow temperature sensor
- Cylinder temperature sensor
- Outlet temperature sensor
- Temperature sensor, low loss header

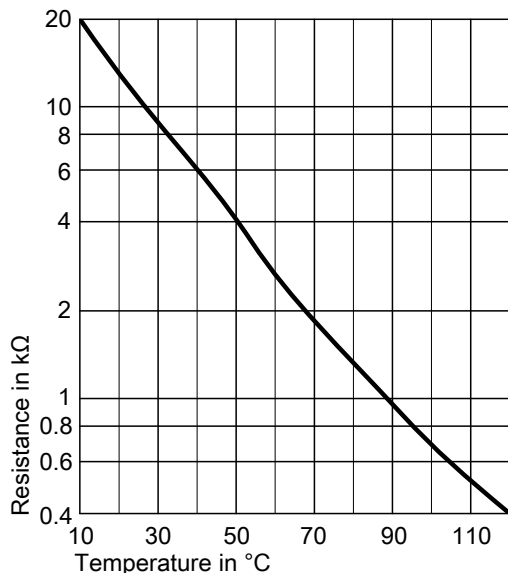

Sensor type: NTC 10 kΩ

- Outside temperature sensor

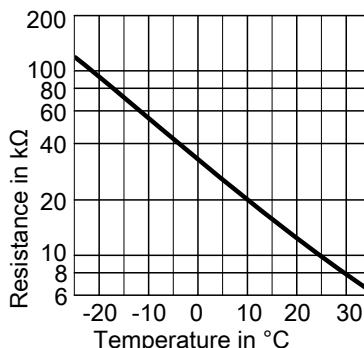

Sensor type: NTC 10 kΩ

Fault during commissioning (fault message F.416)

During commissioning, the control unit checks for correct placement of the flue gas temperature sensor. If fault message F.416 is displayed:

1. Check whether the flue gas temperature sensor is correctly installed (bayonet fitting). See previous diagram.
2. If required, correct the position of the flue gas temperature sensor.
3. Check the flue gas temperature sensor resistance. See previous chapter. Replace faulty flue gas temperature sensor if required.

4. Turn off the ON/OFF switch.
5. Turn the ON/OFF switch back on. Restart the commissioning assistant.
6. Check for leaks on the flue gas side.

Note

If fault message F.416 continues to be displayed although the flue gas temperature sensor has been correctly positioned: Initial commissioning may result in burner faults e.g. caused by air in the gas line. Eliminate the fault and unlock the device.

Check temperature sensors at EM-S1 extension (ADIO electronics module) or at SDIO/SM1A electronics module



Check temperature sensors: Installation and service instructions of relevant accessory.

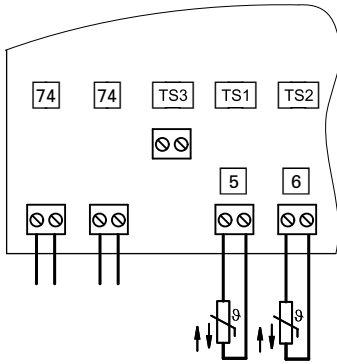

Fig. 56

Check cylinder temperature sensor

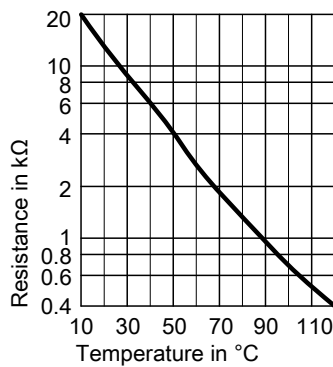

Fig. 57 Sensor type: NTC 10 kΩ

1. Disconnect plug TS1 [5] from the electronics module. Measure the resistance.
2. Compare the sensor resistance to the curve.
3. In the event of severe deviation (> 10 %), replace the sensor.

Check collector temperature sensor

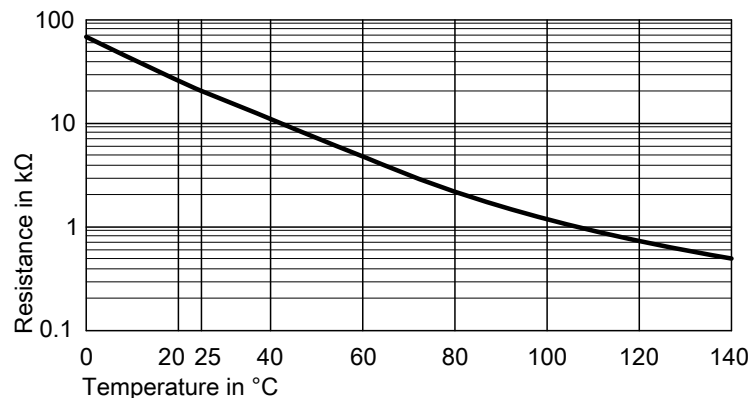



Fig. 58 Sensor type: NTC 20 kΩ

1. Disconnect plug TS2 [6] from the electronics module. Measure the resistance.
2. Compare the sensor resistance to the curve.
3. In the event of severe deviation (> 10 %), replace the sensor.

Repairs (cont.)

Information on replacing the HMU heat management unit and BCU burner control unit

If the BCU burner control unit and/or HMU heat management unit are replaced, the replacement must be carried out with the help of "ViGuide".

 See spare part installation instructions and internet address: www.viguide.info

Replacing the power cable

When replacing the power cable, only use the power cable available as a spare part from Viessmann.

Replacing the HMI connecting cable

! **Please note**
 Incorrect routing of the cable can lead to heat damage and impairment of the EMC properties. For positioning and securing of the cable (fixing point of the cable tie) see connecting cable installation instructions.

Checking the plate heat exchanger

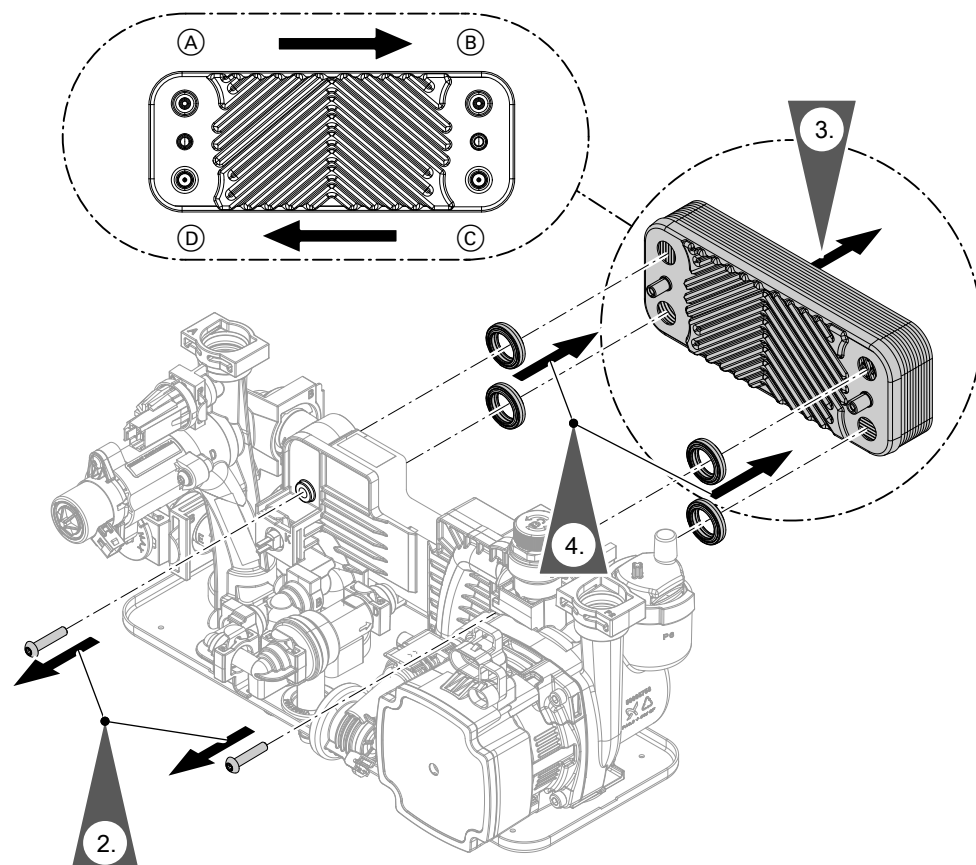

Fig. 59

- (A) Heating water flow
- (B) Heating water return
- (C) Cold water
- (D) DHW

1. Shut off and drain the boiler on the heating water and DHW sides.
2. Undo screws.

Repairs (cont.)

3. Remove plate heat exchanger.

Note

During and after removal, small amounts of water may trickle from the plate heat exchanger.

4. Remove gaskets and dispose of them.
5. Check connections on the DHW side for scaling. Clean or replace the plate heat exchanger as required.
6. Check connections on the heating water side for contamination. Clean or replace the plate heat exchanger as required.

7. Install plate heat exchanger in reverse order using new gaskets.

Tighten screws as tightly as necessary and ensure that the components are undamaged and are functioning correctly throughout service life.

Observe torque settings if a torque wrench is available.

Screw torque: 3.2 Nm ± 0.2

Note

During installation, ensure the connections are positioned and the gaskets seated correctly.



Danger

Risk of electric shock from escaping heating water or DHW.

Check all water side connections for tightness.

Removing the hydraulic unit

In case hydraulic unit components have to be replaced.



Danger

Risk of electric shock from escaping heating water or DHW.

After installation, check all connections on the water side for leaks.

Repairs (cont.)

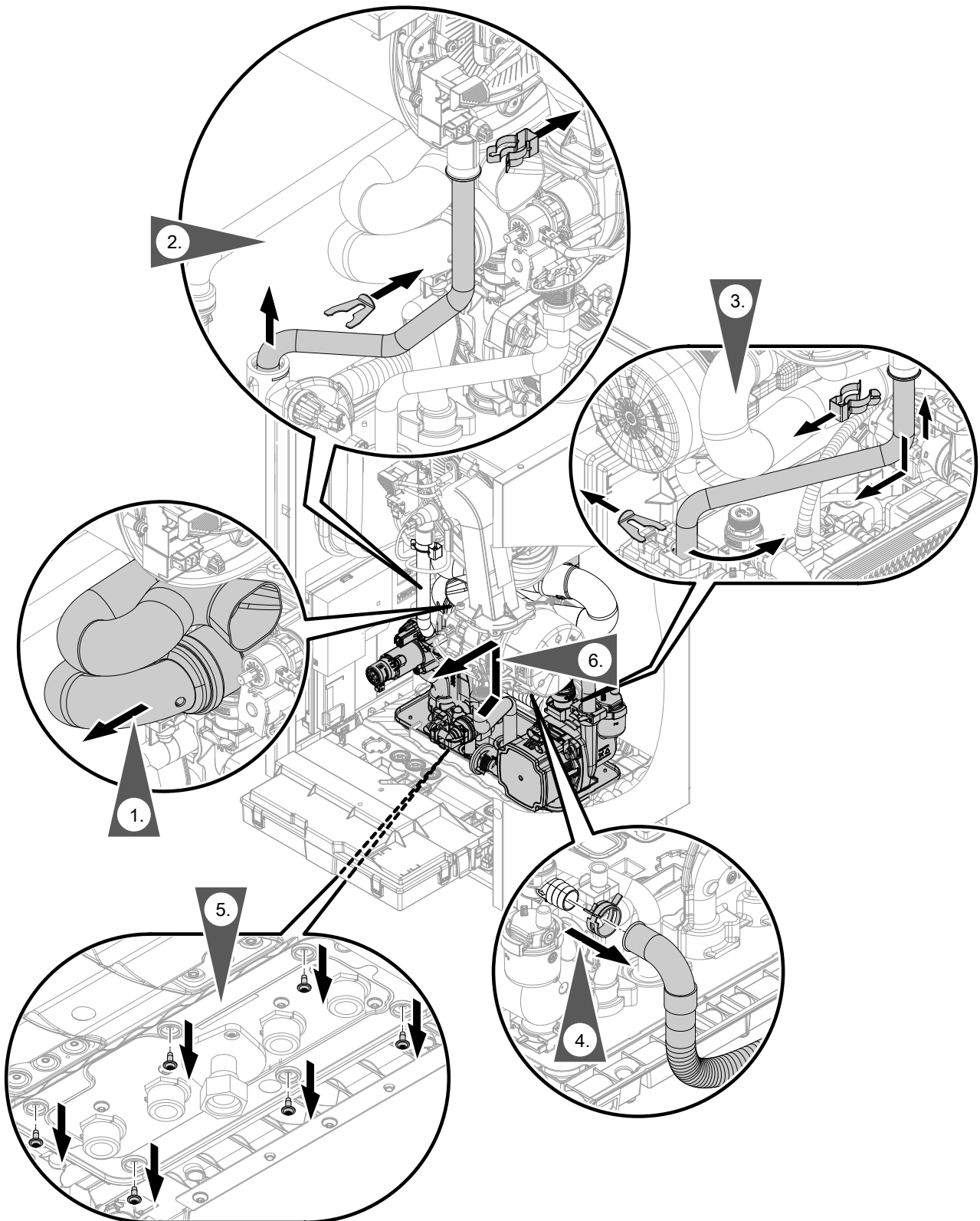

Fig. 60

Checking the fuse

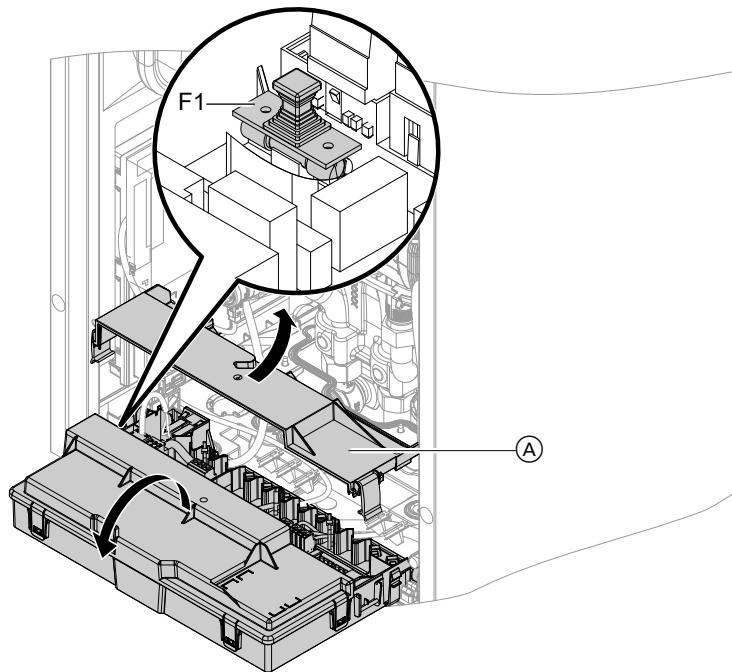

Fig. 61

1. Turn off the ON/OFF switch.
2. Depending on the configuration: Move programming unit together with bracket to service position.
3. Pivot the HMU heat management unit down.
4. Remove cover (A).
5. Check fuse F1 (see connection and wiring diagram).



Danger

Incorrect or improperly fitted fuses can lead to an increased risk of fire.

- Insert fuses without using any force. Position fuses correctly.
- Only use structurally identical types with the specified response characteristics.

Appliance functions

Heating mode

■ Weather-compensated operation:

The rooms are heated in accordance with the room temperature and time program settings.

The control unit determines a set flow temperature for the heat generator, subject to the outside temperature, the room temperature and the slope/level of the heating curve.

■ Room temperature-dependent operation:

System with one heating circuit without mixer. The rooms are heated in accordance with the settings of the room temperature controller/room thermostat (accessories).

If the room temperature controller/room thermostat issues a demand, the standard set flow temperature is maintained. If there is no demand present, the reduced set flow temperature is maintained.

■ Continuous operation without room thermostat:

The rooms are heated according to the time program settings.

In the time phases at standard room temperature, the standard set flow temperature or the set comfort flow temperature is maintained. Outside the set time phases, the reduced set flow temperature is maintained.

Heating circuit pump connection for heating circuit without mixer

Only for systems with several heating circuits.

If a heating circuit without mixer is connected downstream of the low loss header, the circulation pump is connected to output P2. The function of the output is set in the commissioning assistant.



To start the commissioning assistant: See "Commissioning, inspection and maintenance".

If output P2 is being used for another function, the circulation pump can be connected to output P1 or an EM-P1 extension (accessories).

Venting program

During the venting program, the circulation pump will be alternately switched on and off for 30 s over a period of 20 min.

The 3-way diverter valve alternates between central heating and DHW heating for a certain period of time. The burner is switched off during the venting program.



Activate venting program: See chapter "Commissioning, inspection and maintenance".

Filling program

In the delivered condition, the 3-way diverter valve is set to its central position, so the system can be filled completely. After the control unit has been switched on, the 3-way diverter valve no longer goes into its central position.

If the system is to be filled with the control unit switched on, the 3-way diverter valve is moved to its central position in the filling program and the pump is started.



Activate filling program: See chapter "Commissioning, inspection and maintenance".

In this position, the control unit can be switched off and the system can be filled completely. When the function is enabled, the burner shuts down. The program automatically becomes inactive after 20 min.

Heating curve

The heating curves represent the relationship between the outside temperature and the flow temperature.

Simplified: The lower the outside temperature, the higher the flow temperature must be in order to reach the room temperature set point.

Factory settings:

- Slope = 1.4
- Level = 0

Appliance functions (cont.)

Note

If heating circuits with mixer are present in the heating system: The flow temperature of the heat generator is one differential temperature higher than the flow temperature for the heating circuits with mixer. Differential temperature in delivered condition set to 8 K.

The differential temperature is adjustable using the following parameters:

- Heating circuit 2: Parameter 934.5
- Heating circuit 3: Parameter 935.5
- Heating circuit 4: Parameter 936.5

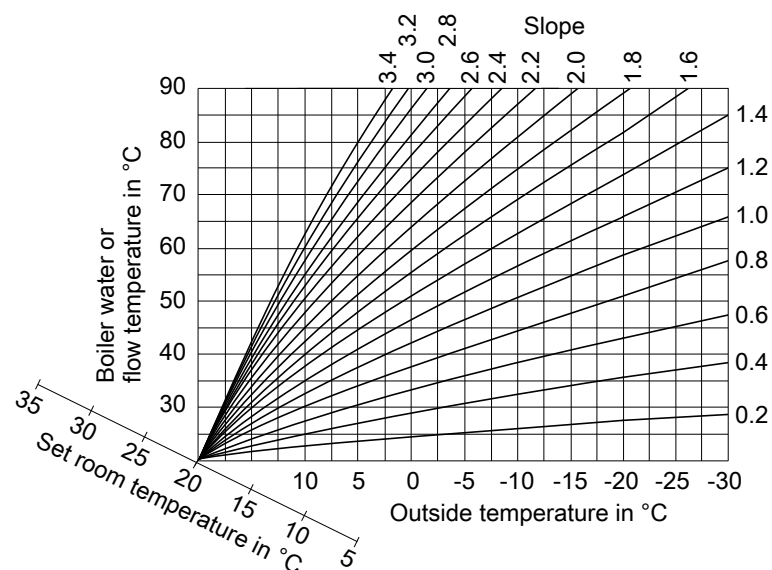

Fig. 62

Slope setting ranges:

- Underfloor heating systems: 0.2 to 0.8
- Low temperature heating systems: 0.8 to 1.6

Set room temperature

Standard room temperature or comfort room temperature

Individually adjustable for each heating circuit. The heating curve is offset along the set room temperature axis. The start and stop points of the heating circuit pumps depend on the Heating limit... outside temperature, heating circuit... setting.

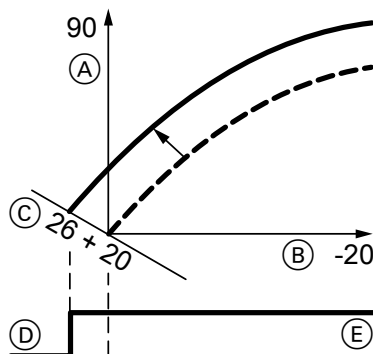

Fig. 63 Example 1: Adjusting the set room temperature from 20 to 26 °C

- Ⓐ Flow temperature in °C
- Ⓑ Outside temperature in °C
- Ⓒ Set room temperature in °C
- Ⓓ Heating circuit pump "OFF"
- Ⓔ Heating circuit pump "ON"

Changing the set room temperature

Operating instructions

Appliance functions (cont.)

Reduced room temperature

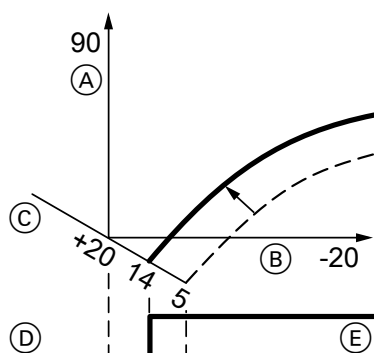
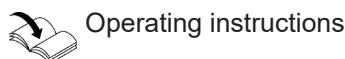

Fig. 64 Example 2: Adjusting the reduced set room temperature from 5 °C to 14 °C

- (A) Flow temperature in °C
- (B) Outside temperature in °C
- (C) Set room temperature in °C
- (D) Heating circuit pump "OFF"
- (E) Heating circuit pump "ON"

Changing the reduced set room temperature



Operating instructions

Changing the slope and level

Individually adjustable for each heating circuit.

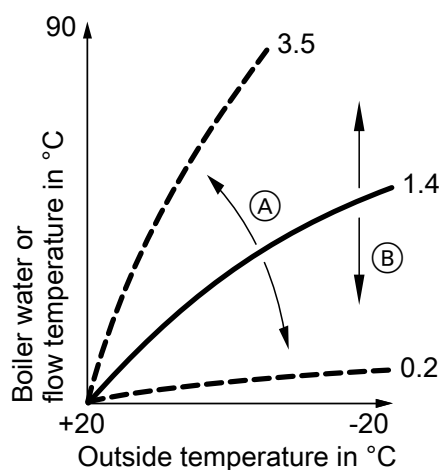

Fig. 65

- (A) Changing the slope
- (B) Changing the level (vertical parallel offset of the heating curve)

Raising the flow temperature of the heating circuits during operation with room temperature hook-up

The higher the value, the greater the influence of the room temperature on the flow temperature of the heating circuit.

Room influence factor parameter

Heating circuit	Parameter
1 (without mixer)	933.7 (only set if just one heating circuit is installed)
2 (with mixer)	934.7
3 (with mixer)	935.7
4 (with mixer)	936.7

Example for determining the increase in the flow temperature using the value of the heating curve when the actual room temperature deviates from the set room temperature:

- Set room temperature = 20.0 °C (RT set)
- Actual room temperature = 18.0 °C (RT actual)
- Heating curve slope = 1.4
- Room influence factor = 8 (delivered condition)

Determining the increase in flow temperature

$(RT_{\text{set}} - RT_{\text{actual}}) \times (1 + \text{slope}) \times \text{room influence factor} / 4 = \text{raising the flow temperature via heating curve value}$

$$(20 - 18) \times (1 + 1.4) \times 8 / 4 = 9.6$$

Increase in flow temperature via heating curve value = 9.6 K

Screed drying

When enabling screed drying, observe the information provided by the screed manufacturer.

When screed drying is activated, the heating circuit pumps of **all** heating circuits are switched on and the flow temperature is maintained at the set profile. After completion (30 days), the heating circuits with mixer are automatically controlled with the set parameters.

Appliance functions (cont.)

Note

With a combi boiler, DHW heating is not possible during screed drying. With a system boiler or storage combi boiler, after 30 minutes DHW heating is suspended for an hour (parameter 1087.1) in order to run the screed drying program.

Different temperature profiles can be set via parameter 897.0.

Note

Temperature profile 6 ends after 21 days.

Observe EN 1264. The report to be provided by the heating contractor must contain the following details regarding heat-up:

- Heat-up data with the relevant set flow temperatures
- Max. flow temperature achieved.
- Operating state and outside temperature at handover

The function continues after a power failure or after the control unit has been switched off. When screed drying has completed or been manually switched off, the system is regulated in accordance with the selected parameters.

Parameter 897.0 "Screed drying":

Temperature profile A (EN 1264-4)

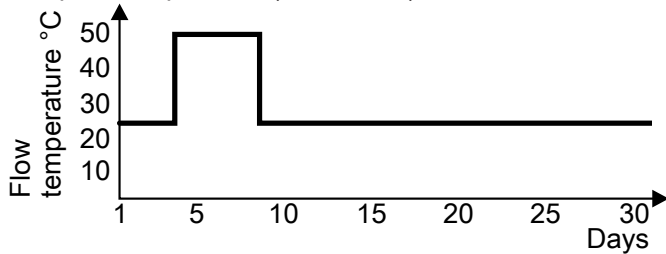

Fig. 66

Temperature profile B (ZV parquet and flooring technology)

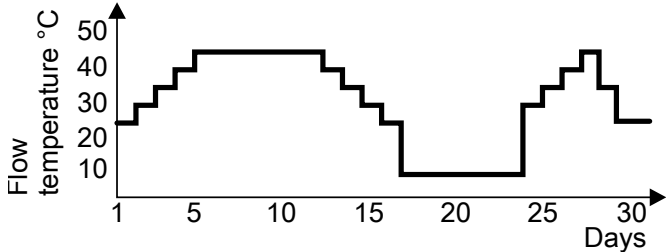

Fig. 67

Temperature profile C

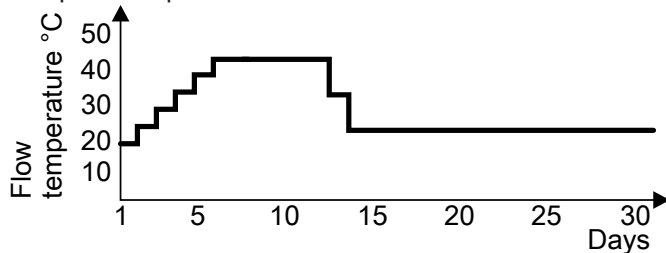

Fig. 68

Temperature profile D

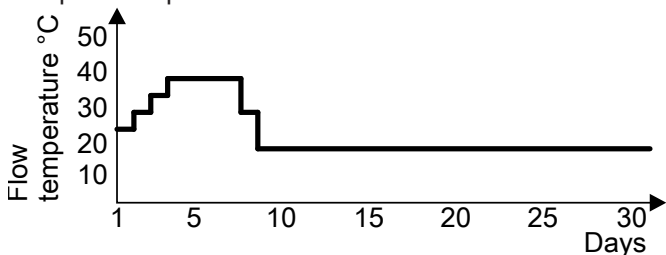

Fig. 69

Appliance functions (cont.)

Temperature profile E

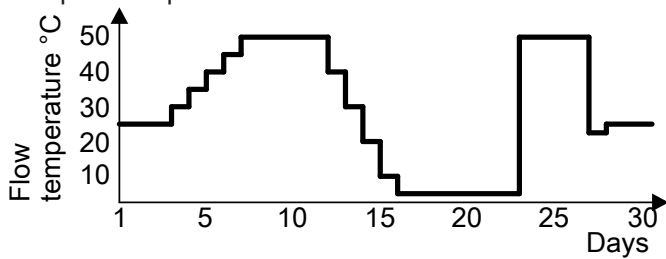

Fig. 70

Temperature profile F

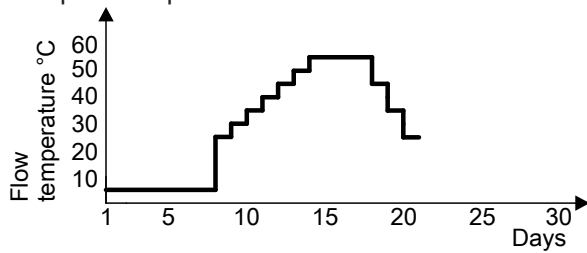

Fig. 71 Ends after 21 days.

Raising the reduced room temperature

During operation at reduced room temperature, the reduced set room temperature can be automatically raised subject to the outside temperature. The temperature is raised in accordance with the selected heating curve, and no higher than the standard set room temperature or comfort room temperature. Depending on which set room temperature will become active in the next time phase.

The outside temperature limits for the start and end of temperature raising can be set in parameters 1139.0 and 1139.1.

Example using the settings in the delivered condition

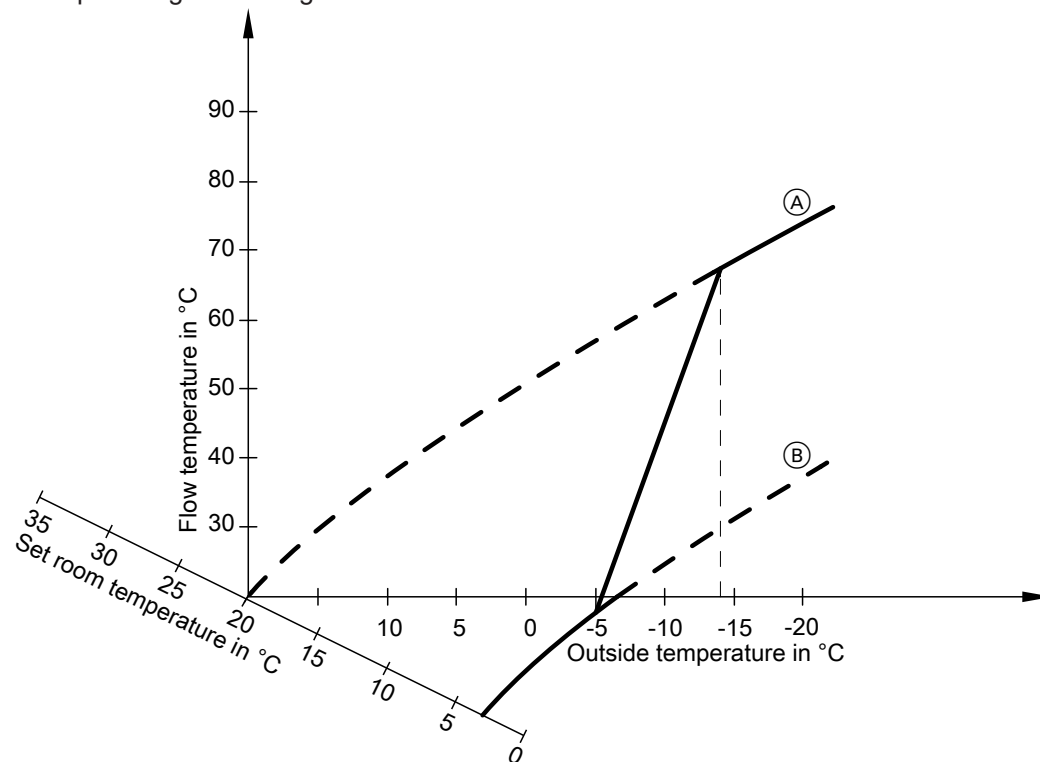

Fig. 72

- Ⓐ Heating curve for operation at standard room temperature or comfort room temperature
- Ⓑ Heating curve for operation at reduced room temperature

Reducing the heat-up time

During the transition from operation at reduced room temperature to operation at standard room temperature or comfort room temperature, the flow temperature will be raised in accordance with the selected heating curve.

The value and duration of the additional increase in the set flow temperature is adjusted in parameters 424.3 and 424.4.

Appliance functions (cont.)

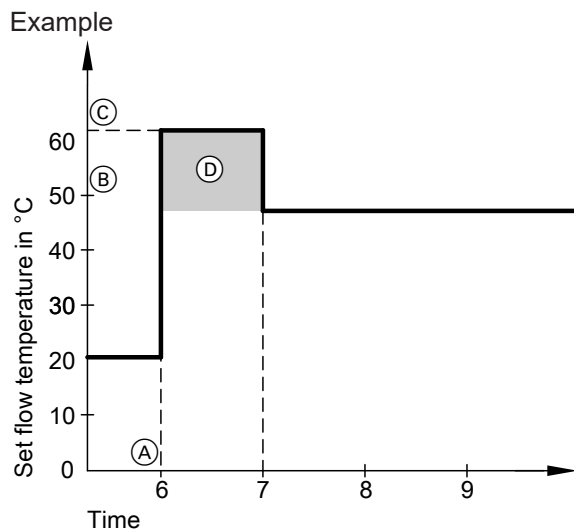

Fig. 73

- (A) Start of operation at standard room temperature or comfort room temperature
- (B) Set flow temperature in accordance with the set heating curve
- (C) Set flow temperature in accordance with parameter 424.3
- (D) Duration of operation with higher set flow temperature in accordance with parameter 424.4: 60 min

DHW heating (system boilers only)

The burner, the circulation pump and the 3-way diverter valve are started or changed over if the cylinder temperature lies 2.5 K below the set cylinder temperature.

In the delivered condition, the set boiler water temperature is 20 K higher than the set cylinder temperature. If the actual cylinder temperature exceeds the set cylinder temperature by 2.5 K, the burner shuts down and circulation pump run-on begins (only with separate DHW cylinder).

**Danger**

Risk of injury due to increased DHW temperature.

Inform the system user of the risk from the raised outlet temperature at the draw-off points.

- Gas condensing system boiler:
If the set DHW temperature is set to over 60 °C
- Gas condensing combi boiler:
If there are several draw-off events in quick succession or several appliance calibration processes

Increased DHW hygiene

The DHW can be heated to a specified (higher) set DHW temperature (approx. 65 °C) for a period of one hour.

**Danger**

Risk of injury due to increased DHW temperature.

Inform the system user of the risk from the raised outlet temperature at the draw-off points. If required, provide on-site scald protection measures.

Function description

Interval function, solar circuit pump

For correct capture of the collector temperature, the interval function cyclically switches on the collector circuit pump briefly.

See parameter 1719.0

External heating circuit hook-up (if installed)

Note

Only in conjunction with weather-compensated operation.

■ Function:

- If the external demand is active (plug 96 or digital input on DIO electronics module closed), the heating circuit is supplied with heat.
- If the external demand is inactive (contact open), heat supply to the heating circuit ends (regardless of the current set room temperature or the switching time).

The following status messages are shown on the display of the control unit:

- S.94 (heating circuit 1)
- S.95 (heating circuit 2)
- S.96 (heating circuit 3)



Please note

There is no frost protection for the connected heating circuits.

■ Connection:

- If just one heating circuit is hooked up, use connection at plug 96: See page 26.
- If several heating circuits (max. 3) are hooked up, connect all contacts at EM-EA1 extension (DIO electronics module) to subscriber no. 1 (rotary switch = 1).



See EM-EA1 extension installation instructions

HMU heat management unit

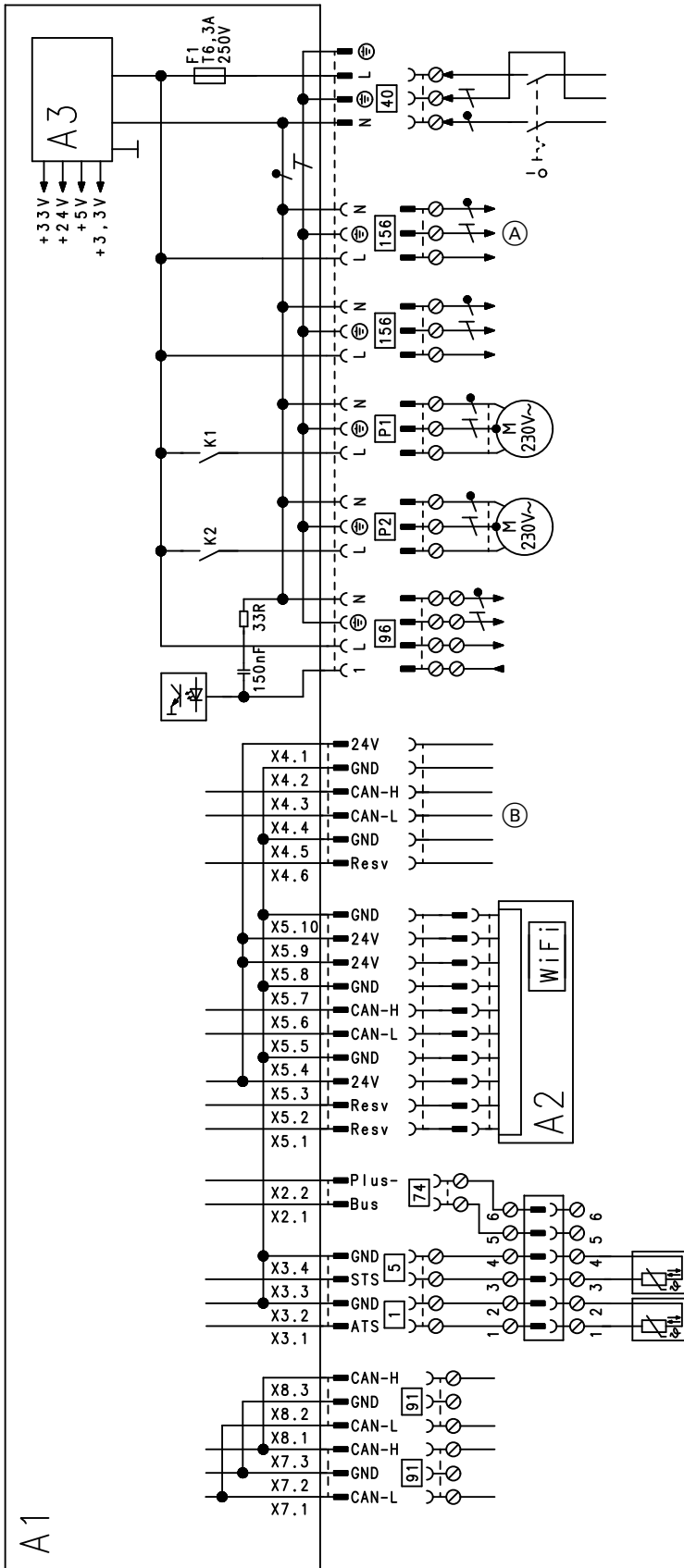

Fig. 74

- A1 HMU heat management unit
- A2 HMI programming unit with communication module (TCU 200)
- A3 Switching mode power supply
- X... Electrical interfaces

- 1 Outside temperature sensor (for weather-compensated operation)
- 5 Cylinder temperature sensor (gas condensing system boiler)
- 40 Power supply

HMU heat management unit (cont.)

- 74 PlusBus
- 91 CAN bus
- 96 230 V floating input, 230 V output. For connecting a floating switching contact, see page 26
- 156 Mains voltage output
- P1 Output 230 V for:
 - Circulation pump for heating circuit without mixer
 - Circulation pump for cylinder heating
- P2 Output 230 V for:
 - Circulation pump for heating circuit without mixer
 - DHW circulation pump
 - Ⓐ To BCU burner control unit
 - Ⓑ To BCU burner control unit

BCU burner control unit

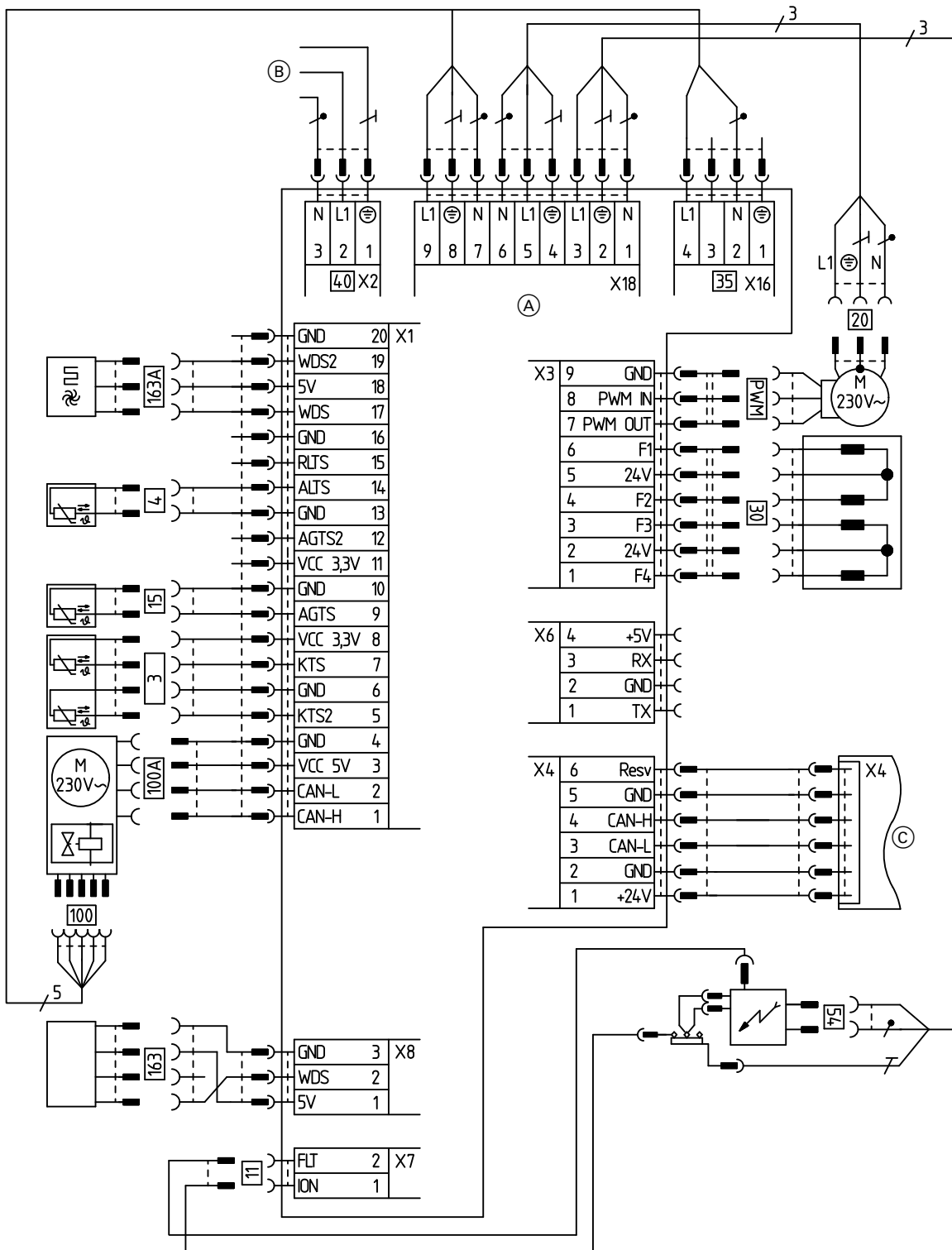

Fig. 75

- | | | | |
|-------|---|------|-------------------------------------|
| PWM | Control signal | 40 | Power supply |
| X... | Electrical interfaces | 54 | Ignition unit |
| 3 A/B | Flow temperature sensors 1 and 2 | 100 | Fan motor |
| 4 | Outlet temperature sensor (gas condensing combi boiler) | 100A | Fan motor control |
| 11 | Ionisation electrode | 163 | Water pressure sensor |
| 15 | Flue gas temperature sensor | 163A | DHW flow sensor |
| 20 | Internal circulation pump (primary circuit pump) | (A) | BCU burner control unit |
| 30 | 3-way diverter valve | (B) | HMU heat management unit (plug 156) |
| 35 | Gas solenoid valve | (C) | HMU heat management unit (plug X4) |

Commissioning/service reports

Settings and test values	Set value	Commissioning	Maintenance/service	Maintenance/service
Date				
Signature				
Static pressure	mbar kPa	≤ 57.5 ≤ 5.75		
Supply pressure (flow pressure)				
<input type="checkbox"/> For natural gas	mbar kPa	See table "Supply pressure" (Commissioning ...)		
<input type="checkbox"/> For LPG	mbar kPa			
<input type="checkbox"/> Enter gas type				
Carbon dioxide content CO₂ With natural gas		See "Checking the combustion quality" (Commissioning ...)		
▪ At lower heating output	% by vol.			
▪ At upper heating output	% by vol.			
For LPG				
▪ At lower heating output	% by vol.			
▪ At upper heating output	% by vol.			
Oxygen content O₂				
▪ At lower heating output	% by vol.			
▪ At upper heating output	% by vol.			
Carbon monoxide content CO				
▪ At lower heating output	ppm	< 1000		
▪ At upper heating output	ppm	< 1000		

Specification

Gas condensing system boiler
Use with single connection

		Type B2HF				
Rated heating output range (to EN 15502)						
$T_F/T_R = 50/30 \text{ }^\circ\text{C}$ (P(50/30))						
Natural gas	kW	1.9 to 11	1.9 to 19	1.9 to 25	1.9 to 32	
LPG	kW	2.5 to 11	2.5 to 19	2.5 to 25	2.5 to 32	
$T_F/T_R = 80/60 \text{ }^\circ\text{C}$ (Pn(80/60))						
Natural gas	kW	1.7 to 10.1	1.7 to 17.5	1.7 to 23	1.7 to 29.3	
LPG	kW	2.2 to 10.1	2.2 to 17.5	2.2 to 23	2.2 to 29.3	
Rated heating output for DHW heating						
Natural gas	kW	1.7 to 17.5	1.7 to 17.5	1.7 to 23	1.7 to 29.3	
LPG	kW	2.2 to 17.5	2.2 to 17.5	2.2 to 23	2.2 to 29.3	
Rated heat input (Qn)						
Natural gas	kW	1.8 to 10.3	1.8 to 17.8	1.8 to 23.4	1.8 to 29.9	
LPG	kW	2.3 to 10.3	2.3 to 17.8	2.3 to 23.4	2.3 to 29.9	
Rated heat input for DHW heating (Qnw)		kW	17.8	17.8	23.4	29.9
Product ID		CE-0085CT0017				
IP rating		IP X4 to EN 60529				
NO_x	Class	6	6	6	6	
Gas supply pressure						
Natural gas	mbar	20	20	20	20	
	kPa	2	2	2	2	
LPG	mbar	50	50	50	50	
	kPa	5	5	5	5	
Max. permiss. gas supply pressure*¹						
Natural gas	mbar	25.0	25.0	25.0	25.0	
	kPa	2.5	2.5	2.5	2.5	
LPG	mbar	57.5	57.5	57.5	57.5	
	kPa	5.75	5.75	5.75	5.75	
Sound power level (to EN ISO 15036-1)						
at partial load	dB(A)	32.8	32.8	32.8	32.8	
At rated heating output (DHW heating)	dB(A)	42.3	42.3	46.1	48.4	
Rated voltage	V	230				
Rated frequency	Hz	50				
Appliance fuse protection	A	6.3				
Backup fuse (power supply)	A	16				
Communication module (integral)						
WiFi frequency band	MHz	2400 to 2483.5				
Max. transmission power	dBm	17				
Low power radio frequency band	MHz	2400 to 2483.5				
Max. transmission power	dBm	6				
Supply voltage	V ==	24				
Power consumption	W	4				
Power consumption (delivered condition)	W	40	48	67	113	

*¹ If the gas supply pressure is higher than the maximum permissible value, install a separate gas pressure governor upstream of the system.

Specification (cont.)

Use with single connection

		Type B2HF			
Rated heating output range (to EN 15502)					
$T_F/T_R = 50/30 \text{ }^\circ\text{C}$ (P(50/30))					
Natural gas	kW	1.9 to 11	1.9 to 19	1.9 to 25	1.9 to 32
LPG	kW	2.5 to 11	2.5 to 19	2.5 to 25	2.5 to 32
$T_F/T_R = 80/60 \text{ }^\circ\text{C}$ (Pn(80/60))					
Natural gas	kW	1.7 to 10.1	1.7 to 17.5	1.7 to 23	1.7 to 29.3
LPG	kW	2.2 to 10.1	2.2 to 17.5	2.2 to 23	2.2 to 29.3
Permissible ambient temperature					
▪ During operation	$^\circ\text{C}$	+5 to +35			
▪ During storage and transport	$^\circ\text{C}$	-5 to +60			
Electronic temperature limiter setting (TN)	$^\circ\text{C}$	91			
Electronic temperature limiter setting	$^\circ\text{C}$	110			
Electronic flue gas temperature limiter setting	$^\circ\text{C}$	110			
Weight					
▪ Excl. heating water	kg	33.0	33.0	33.0	33.0
▪ Incl. heating water	kg	38.6	38.6	38.6	38.6
Water capacity (excl. diaphragm expansion vessel)	l	3.0	3.0	3.0	3.0
Max. flow temperature	$^\circ\text{C}$	82	82	82	82
Max. flow rate (Limit for the use of hydraulic separation)	l/h	See residual head graph			
Nominal circulating water volume At $T_F/T_R = 80/60 \text{ }^\circ\text{C}$	l/h	434	752	988	1259
Diaphragm expansion vessel					
Capacity	l	10	10	10	10
Pre-charge pressure	bar	0.75	0.75	0.75	0.75
	kPa	75	75	75	75
Permiss. operating pressure (PMS)	bar	3	3	3	3
	MPa	0.3	0.3	0.3	0.3
Max. DHW temperature	$^\circ\text{C}$	70	70	70	70
Dimensions					
Length	mm	360	360	360	360
Width	mm	450	450	450	450
Height	mm	700	700	700	700
Gas connection	R	$\frac{3}{4}$	$\frac{3}{4}$	$\frac{3}{4}$	$\frac{3}{4}$
Flue gas connection	\varnothing mm	60	60	60	60
Ventilation air connection	\varnothing mm	100	100	100	100
Supply values Relative to the max. load					
With gas					
Natural gas E	m^3/h	1.88	1.88	2.48	3.16
Natural gas LL	m^3/h	2.19	2.19	2.88	3.68
LPG	kg/h	1.38	1.38	1.82	2.32

Specification (cont.)

Use with single connection

		Type B2HF			
Rated heating output range (to EN 15502)					
$T_F/T_R = 50/30 \text{ °C (P(50/30))}$					
Natural gas	kW	1.9 to 11	1.9 to 19	1.9 to 25	1.9 to 32
LPG	kW	2.5 to 11	2.5 to 19	2.5 to 25	2.5 to 32
$T_F/T_R = 80/60 \text{ °C (Pn(80/60))}$					
Natural gas	kW	1.7 to 10.1	1.7 to 17.5	1.7 to 23	1.7 to 29.3
LPG	kW	2.2 to 10.1	2.2 to 17.5	2.2 to 23	2.2 to 29.3
Flue gas parameters					
Temperature (at a return temperature of 30 °C)					
– At rated heating output	°C	39	41	46	59
– at partial load	°C	38	38	38	38
Temperature (at a return temperature of 60 °C, for DHW heating)	°C	64	65	67	72
Flue gas superheating temperature	°C	120	120	120	120
Mass flow rate (for DHW heating)					
Natural gas					
– At max. heating output	kg/h	31.7	31.7	41.6	54.9
– At partial load (single connection)	kg/h	3.3	3.3	3.3	3.3
LPG					
– At max. heating output	kg/h	30.1	30.1	41.0	53.9
– At partial load (single connection)	kg/h	3.9	3.9	3.9	3.9
Available draught (single connection) ²	Pa	77	200	341	600
	mbar	0.77	2.0	3.41	6.0
Max. amount of condensate	l/h	2.5	2.5	3.3	4.2
To DWA-A 251					
Condensate connection (hose nozzle)	Ø mm	20 to 24	20 to 24	20 to 24	20 to 24
Flue gas connection	Ø mm	60	60	60	60
Ventilation air connection	Ø mm	100	100	100	100
Standard seasonal efficiency [to DIN] at		Up to 98 (H _s) [gross cv]			
$T_F/T_R = 40/30 \text{ °C}$	%				
Energy efficiency class		A	A	A	A
Seasonal central heating energy efficiency	η_s (%)	92	93	94	94

Note

With appliances for use in multiple connection (vertical) and cascades (horizontal), the specification in the table above apply, with the exception of the following data – see table on appliances for multiple connection on page 140

² CH: Available draught 200 Pa; 2.0 mbar

Specification (cont.)

Gas condensing system boiler
Use with multiple connection

		Type B2HF			
Rated heating output range (to EN 15502) $T_F/T_R = 50/30 \text{ °C (P(50/30))}$					
Natural gas	kW	5.6 to 11	5.6 to 19	5.6 to 25	5.6 to 32
$T_F/T_R = 80/60 \text{ °C (Pn(80/60))}$					
Natural gas	kW	5.1 to 10.1	5.1 to 17.5	5.1 to 23	5.1 to 29.3
Rated heating output for DHW heating					
Natural gas	kW	5.1 to 17.5	5.1 to 17.5	5.1 to 23	5.1 to 29.3
Rated heat input (Qn)					
Natural gas	kW	5.3 to 10.3	5.3 to 17.8	5.3 to 23.4	5.3 to 29.9
Mass flow rate (for DHW heating)					
Natural gas					
– At max. heating output	kg/h	31.7	31.7	41.6	54.9
– At partial load (single connection)	kg/h	3.3	3.3	3.3	3.3
Available draught C₁₀ (at header system interface)					
	Pa	25	25	25	25
	mbar	0.25	0.25	0.25	0.25
Minimal permissible differential pressure between flue gas outlet and air inlet for flue system to C₁₀					
	Pa	-200 ^{*3}	-200 ^{*3}	-200 ^{*3}	-200 ^{*3}

Gas condensing combi boiler
Use with single connection

		Type B2KF		
Rated heating output range (to EN 15502) $T_F/T_R = 50/30 \text{ °C (P(50/30))}$				
Natural gas	kW	1.9 to 19	1.9 to 25	1.9 to 32
LPG	kW	2.5 to 19	2.5 to 25	2.5 to 32
$T_F/T_R = 80/60 \text{ °C (Pn(80/60))}$				
Natural gas	kW	1.7 to 17.5	1.7 to 23	1.7 to 29.3
LPG	kW	2.2 to 17.5	2.2 to 23	2.2 to 29.3
Rated heating output for DHW heating				
Natural gas	kW	1.7 to 26.2	1.7 to 30.4	1.7 to 33.5
LPG	kW	2.2 to 26.2	2.2 to 30.4	2.2 to 33.5
Rated heat input (Qn)				
Natural gas	kW	1.8 to 17.8	1.8 to 23.4	1.8 to 29.9
LPG	kW	2.3 to 17.8	2.3 to 23.4	2.3 to 29.9
Rated heat input for DHW heating (Qnw)				
	kW	27.3	31.7	34.9
Product ID		CE-0085CT0017		
IP rating		IP X4 to EN 60529		
NO_x	Class	6	6	6
Gas supply pressure				
Natural gas	mbar	20	20	20
	kPa	2	2	2
LPG	mbar	50	50	50
	kPa	5	5	5

*3 -100 Pa reserved for wind pressure

Specification (cont.)

Use with single connection

		Type B2KF		
Rated heating output range (to EN 15502)				
$T_F/T_R = 50/30 \text{ }^\circ\text{C}$ (P(50/30))				
Natural gas	kW	1.9 to 19	1.9 to 25	1.9 to 32
LPG	kW	2.5 to 19	2.5 to 25	2.5 to 32
$T_F/T_R = 80/60 \text{ }^\circ\text{C}$ (Pn(80/60))				
Natural gas	kW	1.7 to 17.5	1.7 to 23	1.7 to 29.3
LPG	kW	2.2 to 17.5	2.2 to 23	2.2 to 29.3
Max. perm. gas supply pressure^{*4}				
Natural gas	mbar	25.0	25.0	25.0
	kPa	2.5	2.5	2.5
LPG	mbar	57.5	57.5	57.5
	kPa	5.75	5.75	5.75
Sound power level (to EN ISO 15036-1)				
At partial load	dB(A)	32.8	32.8	32.8
At rated heating output (DHW heating)	dB(A)	49.1	50	50.4
Rated voltage	V	230		
Rated frequency	Hz	50		
Appliance fuse protection	A	6.3		
Backup fuse (power supply)	A	16		
Communication module (integral)				
WiFi frequency band	MHz	2400 to 2483.5		
Max. transmission power	dBm	17		
Low power radio frequency band	MHz	2400 to 2483.5		
Max. transmission power	dBm	6		
Supply voltage	V \equiv	24		
Power consumption	W	4		
Power consumption (in the delivered condition)	W	48	67	113
Permissible ambient temperature				
▪ During operation	$^\circ\text{C}$	+5 to +35		
▪ During storage and transport	$^\circ\text{C}$	-5 to +60		
Electronic temperature limiter setting (TN)	$^\circ\text{C}$	91		
Electronic temperature limiter setting	$^\circ\text{C}$	110		
Electronic flue gas temperature limiter setting	$^\circ\text{C}$	110		
Weight				
▪ Excl. heating water	kg	34.5	34.5	34.5
▪ Incl. heating water	kg	40.6	40.6	40.6
Permiss. operating pressure (PMS)	bar	3	3	3
	MPa	0.3	0.3	0.3
Water capacity (excl. diaphragm expansion vessel)	l	3.0	3.0	3.0
Max. flow temperature	$^\circ\text{C}$	82	82	82
Max. flow rate (Limit for the use of hydraulic separation)	l/h	See residual head graph		

^{*4} If the gas supply pressure is higher than the maximum permissible value, install a separate gas pressure governor upstream of the system.

Specification

Specification (cont.)

Use with single connection

		Type B2KF		
Rated heating output range (to EN 15502)				
$T_F/T_R = 50/30 \text{ °C (P(50/30))}$				
Natural gas	kW	1.9 to 19	1.9 to 25	1.9 to 32
LPG	kW	2.5 to 19	2.5 to 25	2.5 to 32
$T_F/T_R = 80/60 \text{ °C (Pn(80/60))}$				
Natural gas	kW	1.7 to 17.5	1.7 to 23	1.7 to 29.3
LPG	kW	2.2 to 17.5	2.2 to 23	2.2 to 29.3
Nominal circulating water volume	l/h	752	988	1259
At $T_F/T_R = 80/60 \text{ °C}$				
Diaphragm expansion vessel				
Capacity	l	10	10	10
Pre-charge pressure	bar	0.75	0.75	0.75
	kPa	75	75	75
Permiss. operating pressure	bar	3	3	3
	MPa	0.3	0.3	0.3
Specific water flow rate	l/min	14.45	15.69	17
Max. DHW temperature	°C	60	60	60
Comfort factor	Stars	3	3	3
Dimensions				
Length	mm	360	360	360
Width	mm	450	450	450
Height	mm	700	700	700
Gas connection	R	$\frac{3}{4}$	$\frac{3}{4}$	$\frac{3}{4}$
Standby instantaneous water heater				
DHW and cold water connections	G	$\frac{1}{2}$	$\frac{1}{2}$	$\frac{1}{2}$
Permiss. operating pressure (DHW side)	bar	10	10	10
	MPa	1	1	1
Minimum pressure, cold water connection	bar	1.0	1.0	1.0
	MPa	0.1	0.1	0.1
Outlet temperature, adjustable	°C	30 to 60	30 to 60	30 to 60
Continuous DHW output	kW	26.2	30.4	33.5
Spec. flow rate at $\Delta T = 30 \text{ K}$ (as per EN 13203-1)	l/min	14.45	15.59	17.04
Flue gas connection	Ø mm	60	60	60
Ventilation air connection	Ø mm	100	100	100
Supply values				
Relative to the max. load and 1013 mbar/15 °C				
With gas				
Natural gas E	m ³ /h	2.89	3.35	3.69
Natural gas LL	m ³ /h	3.36	3.90	4.29
LPG	kg/h	2.12	2.46	2.71

Specification (cont.)

Use with single connection

		Type B2KF		
Rated heating output range (to EN 15502)				
$T_F/T_R = 50/30 \text{ }^\circ\text{C}$ (P(50/30))				
Natural gas	kW	1.9 to 19	1.9 to 25	1.9 to 32
LPG	kW	2.5 to 19	2.5 to 25	2.5 to 32
$T_F/T_R = 80/60 \text{ }^\circ\text{C}$ (Pn(80/60))				
Natural gas	kW	1.7 to 17.5	1.7 to 23	1.7 to 29.3
LPG	kW	2.2 to 17.5	2.2 to 23	2.2 to 29.3
Flue gas parameters				
Temperature (at a return temperature of 30 °C)				
– At rated heating output	°C	41	46	59
– at partial load	°C	38	38	38
Temperature (at a return temperature of 60 °C, for DHW heating)	°C	70	74	77
Flue gas superheating temperature	°C	120	120	120
Mass flow rate (for DHW heating)				
Natural gas				
– At max. heating output	kg/h	49.3	57.3	62.1
– At partial load (single connection)	kg/h	3.3	3.3	3.3
LPG				
– At max. heating output	kg/h	49.2	57.1	61.1
– At partial load (single connection)	kg/h	3.9	3.9	3.9
Available draught ^{*5}	Pa	200	341	387
	mbar	2.0	3.41	3.87
Temperature (for DHW heating)	°C	70	74	77
Max. temperature	°C	120	120	120
Max. amount of condensate	l/h	2.5	3.3	4.2
To DWA-A 251				
Condensate connection (hose nozzle)	Ø mm	20 to 24	20 to 24	20 to 24
Flue gas connection	Ø mm	60	60	60
Ventilation air connection	Ø mm	100	100	100
Standard seasonal efficiency [to DIN] at				
$T_F/T_R = 40/30 \text{ }^\circ\text{C}$	%	Up to 98 (H _s) [gross cv]		
Energy efficiency class		A	A	A
Seasonal central heating energy efficiency	η_s (%)	93	93	94

Note

With appliances for use in multiple connection (vertical) and cascades (horizontal), the specification in the table above apply, with the exception of the following data – see table on appliances for multiple connection on page 144

Specification (cont.)**Gas condensing combi boiler****Use with multiple connection**

		Type B2KF		
Rated heating output range (to EN 15502) $T_F/T_R = 50/30 \text{ °C (P(50/30))}$				
Natural gas	kW	5.6 to 19	5.6 to 25	5.6 to 32
$T_F/T_R = 80/60 \text{ °C (Pn(80/60))}$				
Natural gas	kW	5.1 to 17.5	5.1 to 23	5.1 to 29.3
Rated heating output for DHW heating				
Natural gas	kW	5.1 to 26.2	5.1 to 30.4	5.1 to 33.5
Rated heat input (Qn)				
Natural gas	kW	5.3 to 17.8	5.3 to 23.4	5.3 to 29.9
Mass flow rate (for DHW heating)				
Natural gas				
– At max. heating output	kg/h	49.3	57.3	62.1
– Partial load multiple connection overpressure	kg/h	9.7	9.7	9.7
Available draught C₁₀ (at header system interface)				
	Pa	25	25	25
	mbar	0.25	0.25	0.25
Minimal permissible differential pressure between flue gas outlet and air inlet for flue system to C₁₀				
	Pa	-200 ^{*3}	-200 ^{*3}	-200 ^{*3}

Note

The supply values are only for reference (e.g. in the gas contract application) or for a supplementary, rough estimate to check the volumetric settings. Due to factory settings, the gas pressure must not be altered from these values. Reference: 15 °C, 1013 mbar (101.3 kPa).

Flue system types

Available in the following countries	Flue system types
AE, AM, AZ, BA, BG, BY, CH, CY, CZ, DK, EE, ES, FI, FR, GB, GR, HR, HU, IE, IS, IT, KG, KZ, LI, LT, LV, MD, ME, MT, NL, NO, PL, PT, RO, RS, RU, SE, SK, TR, UA, UZ	B ₂₃ , B _{23P} , B ₃₃ , C ₁₃ , C ₃₃ , C ₄₃ , C ₅₃ , C ₆₃ , C ₈₃ , C _{83P} , C ₉₃
BE	B ₂₃ , B _{23P} , B ₃₃ , C ₁₃ , C ₃₃ , C ₄₃ , C ₅₃ , C ₈₃ , C _{83P} , C ₉₃
DE, LU, SI	B ₂₃ , B _{23P} , B ₃₃ , C _{13X} , C _{33X} , C _{43X} , C _{53X} , C _{63X} , C _{83X} , C _{83P} , C _{93X}

Gas categories

Available in the following countries	Gas categories
AM, AZ, BY, KG, KZ, MD, RU, UA, UZ	I _{2N} /I _{2H}
AE, AM, AZ, BA, BG, BY, CZ, DK, EE, ES, FI, GB, GR, HR, HU, IE, IS, IT, KG, KZ, LI, LT, LV, LU, MD, ME, MT, NO, PT, RO, RS, RU, SE, SI, SK, TR, UA, UZ	II _{2N3P} /II _{2H3P}
BE	I _{2N}
DE, FR	II _{2N3P}
CY	I _{3P}

*3 -100 Pa reserved for wind pressure

Specification (cont.)

Available in the following countries	Gas categories
NL	II _{2EK3P}
PL	II _{2N3P} /II _{2ELW3P}

The gas condensing boiler is suitable for operation with natural gas containing a hydrogen blend of up to 20 % by volume.

Electronic combustion control unit

The electronic combustion controller utilises the physical correlation between the level of the ionisation current and the air ratio λ . The maximum ionisation current is achieved at an air ratio of 1 for all gas qualities. The ionisation signal is evaluated by the combustion controller. The air ratio is regulated to a value that is between $\lambda = 1.2$ and 1.5. This range provides for an optimum combustion quality. Thereafter, the electronic gas train regulates the required gas volume subject to the prevailing gas quality.

To check the combustion quality, the CO₂ content or the O₂ content of the flue gas is measured. The prevailing air ratio is determined using the actual values.

To achieve optimum combustion control, the system regularly carries out an automatic self-calibration; also after power failures (shutdown). For this, the combustion is briefly regulated to maximum ionisation current (corresponding to air ratio $\lambda = 1$). Self-calibration takes place shortly after the burner starts. The process lasts approx. 20 s during which higher than normal CO emissions may occur briefly.

Disposal

Final decommissioning and disposal

Viessmann products can be recycled. Components and substances from the system are not part of ordinary domestic waste.

For decommissioning, isolate the system from the power supply and allow components to cool down where appropriate. All components must be disposed of correctly.

Ordering individual parts for accessories

Please affix accessory labels with part numbers here.
Please specify the relevant part no. when ordering individual parts.



Service

Certificates

Declaration of conformity

We, Viessmann Limited, Hortenwood 30, Telford TF1 7YP, United Kingdom, declare as authorised representative of the manufacturer and in sole responsibility for the manufacturer, that the named product complies with the applicable UK regulations in terms of its design and operational characteristics. Viessmann Limited, Hortenwood 30, Telford TF1 7YP, United Kingdom, hereby declares that the radio equipment type of the named product is in compliance with The Radio Equipment Regulations 2017.

Using the serial number, the full Declaration of Conformity can be found on the following website:

www.viessmann.co.uk/conformity

Manufacturer's certificate according to the 1st BImSchV [Germany]

We, Viessmann Climate Solutions SE, D-35108 Allendorf, confirm that the product **Vitodens 200-W** complies with the NO_x limits specified by the 1st BImSchV, paragraph 6 [Germany].

Allendorf, 1 March 2021

Viessmann Climate Solutions SE



Authorised signatory Uwe Engel
Senior Vice President Engineering & Technology

Keyword index

- A**
Angle of penetration..... 31
- B**
Back draught safety device..... 53
Boiler water temperature sensor..... 117
Burner control unit..... 135
– Connection diagram..... 135
Burner gasket..... 52
Burner gauze assembly..... 52
Burner installation..... 56
Burner removal..... 51
- C**
Checking functions..... 85
Combustion chamber cleaning..... 54
Combustion controller..... 145
Combustion quality, checking..... 59
Commissioning..... 40
Commissioning assistant..... 36
Condensate drain..... 55
Connection diagrams..... 133
Connection error..... 88
Control unit
– Connection diagram..... 133
Control unit functions..... 125
Converting the gas type..... 43
Cylinder temperature sensor..... 117
- D**
Delay, DHW heating..... 68
Determining the increase in flow temperature..... 127
DHCP..... 31
DHW boost heating..... 61, 131
DHW circulation pump connection..... 26
DHW heating..... 131
DHW hygiene..... 61, 131
DHW temperature, raised..... 61, 131
Diaphragm expansion vessel..... 40
Dynamic IP addressing..... 31
- E**
Electronic combustion controller..... 145
Expansion vessel..... 58
- F**
Fault codes..... 89
Fault message, calling up..... 88
Fault messages
– Display..... 88
Fault messages, calling up..... 85
Faults
– Commissioning..... 47
– Display..... 88
Filling function..... 41, 125
Fill water..... 40
Flow limiter..... 57
Flow pressure..... 46
Flow temperature sensor..... 117
Flue gas temperature sensor..... 118
Front panel removal..... 14
Function descriptions..... 125
Function sequence..... 47
Fuse..... 124
- G**
Gas supply pressure..... 46
Gas train..... 46
Gas type..... 43
Gas type conversion..... 43
- H**
Heating circuit pump for heating circuit without mixer.... 125
Heating contractor
– Contact details..... 43
Heating curve..... 60, 125
Heating curve level..... 127
Heating curve slope..... 127
Heating output, setting..... 48
Heating surface cleaning..... 54
Heating water, topping up..... 41
Heat-up time..... 130
- I**
Ignition..... 53
Ignition electrodes..... 53
Information messages..... 113
Internet, connecting..... 39
Ionisation electrode..... 53
IP addressing..... 31
- L**
Language selection..... 36
Leak test, balanced flue system..... 50
- M**
Maintenance display
– Resetting..... 61
Maintenance message
– Checking..... 61
– Resetting..... 61
Manufacturer's certificate 148
Message history..... 88
Messages, calling up..... 85
- O**
Operating conditions, checking..... 84
Operating data, checking..... 84
Operating data call-up..... 84
Operational reliability..... 31
Outside temperature sensor..... 25, 117

P	
Parameter	
– Automatic summer/wintertime changeover.....	63
– Burner hours until next service.....	64
– Calorific value, gas.....	64
– Clear maintenance messages.....	65
– Cylinder priority on heating circuit.....	70, 71, 72
– DHW circulation pump function.....	66
– Differential temperature, heating circuit.....	71, 72
– Display correction for outside temperature.....	62
– Energy saving functions, heating circuit.....	75, 76
– Flow rate, solar circuit at max. pump speed.....	78
– Frost protection configuration, heating circuit 1.....	77
– Frost protection configuration, heating circuit 2.....	77
– Frost protection configuration, heating circuit 3.....	78
– Frost protection configuration, heating circuit 4.....	78
– Gas volume correction factor.....	63
– Heat transfer medium, solar circuit.....	79
– Integral threshold value.....	66
– Interval function, solar circuit pump.....	81
– Interval until next service.....	65
– Max. solar circuit pump speed.....	78
– Max. speed, heating circuit pump.....	73
– Maximum collector temperature.....	79
– Maximum cylinder temperature for solar DHW heating.....	79
– Maximum heating output.....	65
– Min. solar circuit pump speed.....	78
– Min. speed, heating circuit pump.....	73
– Minimum collector temperature.....	79
– Minimum heating output.....	66
– Number of cycles DHW circulation pump.....	67
– Outside temperature limit.....	64
– Room influence factor, heating circuit... 70, 71, 72, 73	
– Room temperature hook-up, heating circuit.....	70, 71, 72, 73
– Run-on, circulation pump	67
– Scald protection activation.....	67
– Screed drying.....	63
– Set DHW temperature for reheating suppression... 80	
– Set flow temperature for external demand.....	62
– Set start point, cylinder heating.....	68
– Source for date and time.....	64
– Stagnation time reduction.....	80
– Start temperature differential, solar circuit pump... 80	
– Start temperature differential for central heating backup/solar preheating.....	81
– Start temperature for thermostat function.....	80
– Stop temperature differential, solar circuit pump.... 80	
– Stop temperature differential for central heating backup/solar preheating.....	81
– Stop temperature for thermostat function.....	80
Parameters.....	62
– DHW circulation pump for DHW heating.....	67
– DHW circulation pump for hygiene function.....	66
– Energy saving functions, heating circuit.....	76, 77
– Groups.....	62
– Heating limit: Economy function, outside temperature, heating circuit 1.....	75
– Heating limit: Economy function, outside temperature, heating circuit 2.....	75
– Heating limit: Economy function, outside temperature, heating circuit 3.....	75
– Heating limit: Economy function, outside temperature, heating circuit 4.....	75
– Maximum flow temperature limit, heating circuit 1.. 73	
– Maximum flow temperature limit, heating circuit 2.. 74	
– Maximum flow temperature limit, heating circuit 3.. 74	
– Maximum flow temperature limit, heating circuit 4.. 74	
– Minimum flow temperature limit, heating circuit 1... 73	
– Minimum flow temperature limit, heating circuit 2... 74	
– Minimum flow temperature limit, heating circuit 3... 74	
– Minimum flow temperature limit, heating circuit 4... 74	
– Setting local time.....	62
– Speed of boiler circuit pump.....	65
– Speed of circulation pump for storage tank heating.....	68
Parameters, calling up.....	62
Parameters for commissioning.....	60
Passwords	
– Changing.....	84
– Resetting.....	84
Plate heat exchanger.....	121
PlusBus subscribers	
– Number.....	27
Port 123.....	31
Port 443.....	31
Port 80.....	31
Port 8883.....	31
R	
Raising flow temperature	
– Operation with room temperature hook-up.....	127
Raising reduced room temperature.....	129
Range of WiFi connections.....	31
Reduced set room temperature.....	127
Reducing heat-up output.....	129
Reducing heat-up time.....	130
Relay test.....	85
Repairs.....	114
Report.....	136
Requirements.....	31
Room temperature hook-up.....	127
Runtime, DHW heating.....	68
S	
Screed drying.....	127
Screed drying function.....	50, 127
Seal rings, replacing.....	42
Security parameters.....	31
Service menu	
– Calling up.....	83
– Exiting.....	84
Service messages.....	112
Service messages, calling up.....	85
Set room temperature	
– Setting.....	126
Static pressure.....	46
Status messages.....	112

Keyword index (cont.)

Subscriber number		Trap.....	20, 36, 55
– Extensions.....	81	Type plate.....	9
– Setting.....	81		
Subscriber number of connected component.....	88	V	
Summer economy control.....	75	Venting program.....	125
Supply pressure.....	45, 46		
Switch S1.....	81	W	
System configuration.....	36, 62	Warning messages.....	113
System filling.....	40	Warning messages, calling up.....	85
System pressure.....	40	WiFi connection.....	39
System requirements.....	31	WiFi connection range.....	31
System schemes.....	60	WiFi network.....	39
		WiFi router.....	31
T		Wiring diagram.....	133
Tightness test.....	42		
Topping up.....	41		

Viessmann Climate Solutions SE
35108 Allendorf / Germany
Telephone: +49 6452 70-0
Fax: +49 6452 70-2780
www.viessmann.com



Viessmann Limited
Hortonwood 30, Telford
Shropshire, TF1 7YP, GB
Telephone: +44 1952 675000
Fax: +44 1952 675040
E-mail: info-uk@viessmann.com

5593201 Subject to technical modifications.