

Oil condensing cast iron boiler
VITORONDENS 200-T

VIESSMANN



Oil condensing technology

Vitorondens 200-T 20.2 to 107.3 kW

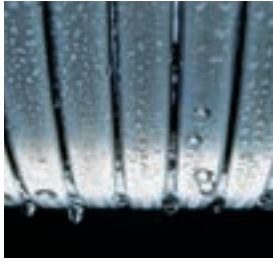

Inox-Radial heat exchanger – durable and efficient

10 Year Warranty

on all stainless steel heat exchangers for oil or gas condensing boilers up to 150 kW

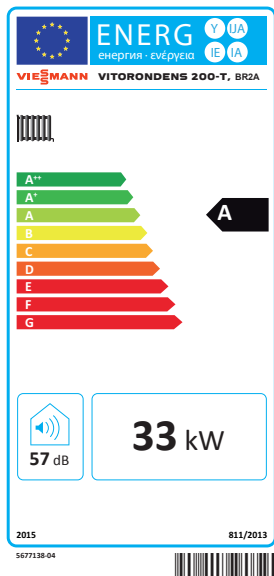

Compact, affordable cast iron oil condensing boiler for modernisation projects

The Vitorondens 200-T is a floorstanding cast iron oil condensing boiler with an attractive price/performance ratio. Their dimensions are impressively compact and they are particularly suitable for modernisation projects.

DHW cylinders from Viessmann's comprehensive product range are available for the Vitorondens 200-T.

Combining the durable Eutectoplex heating surface with the downstream Inox-Radial heat exchanger made from stainless steel separates combustion and condensation effectively. The benefit lies in the fact that the combustion residues remain in the combustion chamber, whilst the combustion gases can condense in the heat exchanger without leaving any residues behind.

The Vitoflame 300 blue flame oil burner is designed for all commercially available EL-type fuel oils, and ensures particularly clean, environmentally responsible and efficient combustion. As an option, up to ten percent bio-oil can be added to the fuel oil. In addition a Kerosene conversion kit is available for selected models.

Easy and convenient control

The Vitotronic 200 control unit with plain text display and graphic support enables easy, self-explanatory operation with user prompts. The Vitotronic enables the convenient control of heating systems with one heating circuit without mixer and up to two heating circuits with mixer.



The Eutectoplex heating surface guarantees a long service life and a high degree of operational reliability.

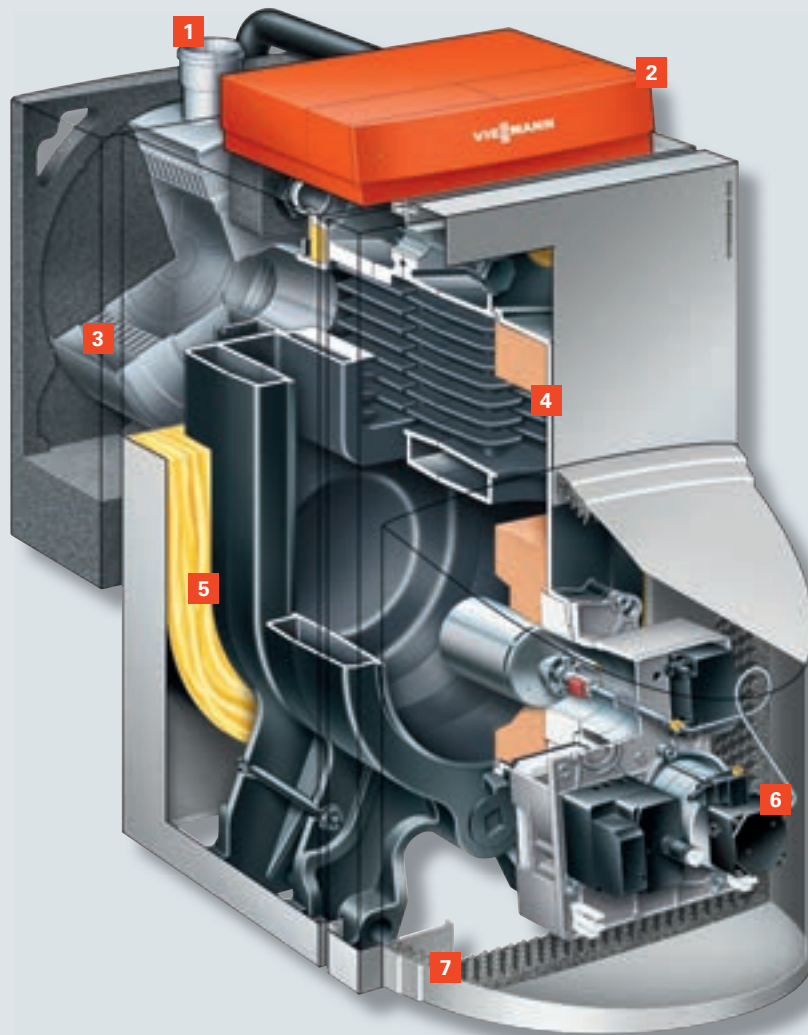

Vitorondens 200-T

- 1 Flue outlet
- 2 Boiler controls
- 3 Secondary heat exchanger
- 4 Primary heat exchanger
- 5 Thermal insulation
- 6 Burner
- 7 Sound insulation

Vitorondens 200-T cast iron condensing boiler



Vitorondens 200-T with output ranging from 67.6 to 107.3 kW (Burner cover only with Vitoflame burner)

Take advantage of these benefits

- Affordable cast iron oil condensing boilers for modernisation projects
- Standard seasonal efficiency [to DIN]: up to 97 % (Hs) [gross cv] / 103 % (Hi) [net cv]
- Proven components (Eutectoplex heating surface) for high operational reliability and a long service life
- Downstream stainless steel Inox-Radial heat exchanger that cleans itself
- Clean combustion thanks to the Vitoflame 300 blue flame oil burner
- Jet Flow system for optimum heating water distribution
- Flexible installation through balanced (up to 53.7 kW) or open flue operation
- Easy-to-operate Vitotronic control unit with plain text and graphic display
- All commercially available EL-type fuel oils can be used. Also for fuel oil to DIN 51603-6-EL A Bio 10: low sulphur fuel oil EL with up to 10 % bio-components (FAME)
- Quiet operation through external flue gas silencer option
- Time savings during installation, as thermal insulation and control unit are prefitted with the Vitorondens 200-T (up to 53.7 kW)
- Easy handling as the Vitorondens 200-T (from 67.6 to 107.3 kW) components are delivered separately. The boiler body is delivered as a block, whilst thermal insulation, downstream heat exchanger and control unit are fitted on site
- Kerosene can be used on selected models with a conversion kit

Technical Data Vitorondens 200-T



Vitorondens 200-T (20.2 to 53.7 kW)

Rated heating output range (50/30 °C)	kW	20.2	24.6	28.9	35.4	42.8	53.7
Rated heating output range (80/60 °C)	kW	18.8	22.9	27	33	40	50
Dimensions							
Length	mm	1226	1226	1362	1362	1662	1662
Width	mm	500	500	500	500	500	500
Height	mm	940	940	940	940	940	940
Weight	kg	147	147	184	184	224	224
Energy efficiency class		A	A	A	A	A	A



Vitorondens 200-T (67.6 to 107.3 kW)

Rated heating output range (50/30 °C)	kW	67.6	85.8	107.3
Rated heating output range (80/60 °C)	kW	63	80	100
Dimensions				
Length	mm	1704	1704	1704
Width	mm	600	600	600
Height	mm	1149	1149	1149
Weight	kg	348	348	348
Energy efficiency class		A	A	A

Your trade partner