

**Coldroom TectoCell Compact 80**  
**Coldroom and deep-freezing room**  
**TectoCell Compact 100**

**VIESSMANN**

**GB**

Assembly and  
Operating Manual  
6026901-02 GB

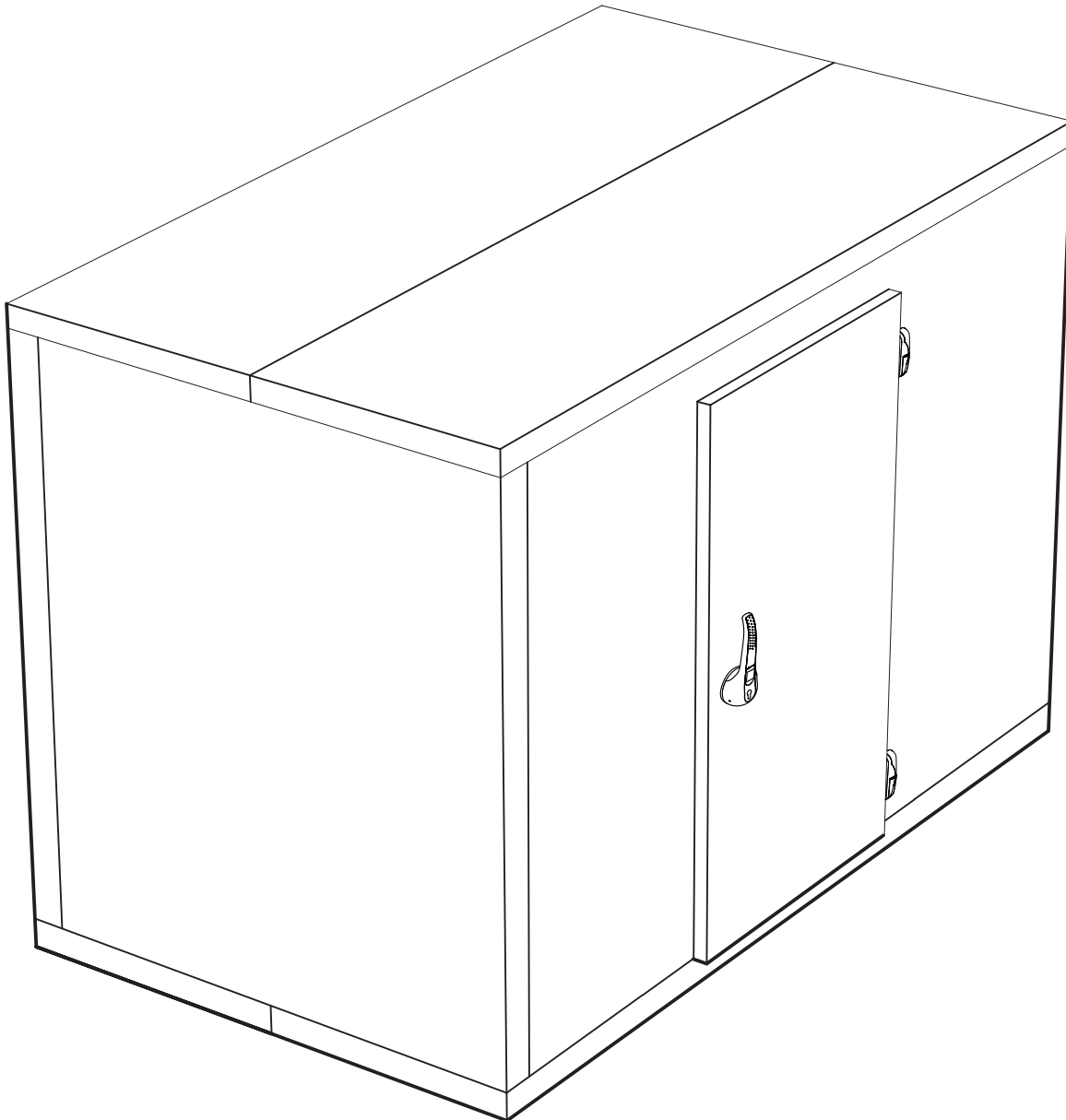

---

**Please read this assembly manual carefully prior to assembling or commissioning the unit. Your specialist refrigeration technician will be glad to explain the functions of the coldroom and instruct you in its operation.**

**All work on the device and the refrigeration unit must be carried out by an authorised refrigeration specialist.**

**Any work on the electrical parts of the coldroom must be done by qualified electricians. The plug must be separated from the socket and protected from reinsertion and/or the power supply must be turned off at the source and protected from being switched on while work is in progress.**

---

General notice (liability): the details of this technical documents serve for description. Consents regarding the availability of certain features or regarding a certain purpose always require a special written agreement.

**1. General notes**

- 1.1 Area of validity
- 1.2 Extract from the conditions of guarantee
- 1.3 Supplied condition
- 1.4 Unpacking and Handling
- 1.5 Assembly of the coldroom
- 1.6 Disposing of the coldroom

**2. Preliminary work**

- 2.1 Compensation for uneven floor
- 2.2 Coldrooms with flooring ventilation  
(Coldroom temperature under - 5°C)
- 2.3 Coldrooms without flooring ventilation

**3. Coldroom assembly**

- 3.1 Connecting the coldroom panels
- 3.2 Assembly of the flooring panels
- 3.3 Assembly of the wall panels
- 3.4 Assembly of the door
- 3.5 Assembly of the ceiling panels
- 3.6 Assembly of the door threshold
- 3.7 Removing transportation securing plates
- 3.8 Adjusting the hinges
- 3.9 Door lock fastener
- 3.10 Mechanical works on the door or the hatch
- 3.11 Coldroom without flooring panels
- 3.12 Closing the operational openings of the cam locks in the wall and ceiling panels

**4. Electrical connections****5. Miscellaneous**

- 5.1 Replacement of cylinder lock on rotary handle lock
- 5.2 Emergency release

**6. Commissioning**

- 6.1 Commissioning the coldroom
- 6.2 Permissible loads for flooring panels
- 6.3 Deactivation
- 6.4 Cleaning the coldroom

**7. Energy saving and storage of refrigerated products**

- 7.1 Notes on energy savings
- 7.2 Storing refrigerated goods

## 1.1 Area of validity

This assembly manual is valid for TectoCell coldrooms with the following surfaces:

- Viessmann Standard white powder coating
- stainless steel flooring

## 1.2 Extract from the conditions of guarantee

No guarantee is assumed for damage resulting from improper use, improper assembly or operation by the buyer or other parties, natural wear, improper or negligent handling, or chemical/electro chemical influence, insofar as this is not our fault, or resulting from inattention to the assembly, operating and maintenance instructions, improper alterations or maintenance done by the buyer or third parties, or as a result of use of parts supplied by other manufacturers.



### Caution!

The ceiling panels are not designed for additional loads (i.e. snow or wind pressure). Prior to accessing on the ceiling or installing a ceiling refrigeration unit, or other elements such as hanging rails, pipes, etc., additional support must be provided during assembly.



### Attention!

**During installation of the refrigeration unit, it must be ensured that the evaporation ventilator does not blow on the door and on the pressure compensation valve.**

## 1.3 Supplied condition

The TectoCell coldroom and deep-freezing room is supplied in individual packing units. The individual panels are designated by labels or numbers.

Door frame heating and extra socket are installed and prewired in the door frame.

The door is already installed in the door frame.

The accessories for assembly are packed separately.

## 1.4 Unpacking and Handling

- Prior to and during unpacking a visual check of the panels must be made in order to determine if any damage has occurred during transport.
- Any damage must be noted immediately on the freight papers and these must be sent to Viessmann. Please note „Conditions in case of damage“! As a rule, the „General Conditions for Transport Damage and Hidden Transport Damage“ apply.
- Before the packing material is disposed of, ensure that it contains no loose parts are in it.
- In order to process the damage claim properly, we request exact details of the damage (pictures) as well as Type Designation and serial number.

### 1.5 Assembly of the coldroom

Install the coldroom in a well ventilated room to ensure that the heat produced by the refrigeration unit is properly released and the room is not excessively heated. This will reduce the running time of the refrigeration unit, thus reducing running costs and the wear on the refrigeration unit. The distance of the coldroom to the wall, and the space above the coldroom should be a minimum of 50 mm for coldrooms in above zero applications. For coldrooms in below zero applications the space should be at least 100 mm. Please see the assembly instructions for the required clearance above the cell for a refrigeration unit. The assembly height has to be arise according to the potential prop construction. Before starting to install the device, check the dimensions of the intended place of installation. With this, also the right angularity has to be checked by diagonal measurement.

It should be ensured that the flooring panels are only installed on even and smooth floors (according German VOB regulations). In case of uneven floors (e.g. cement) the difference must be compensated for using flooring inserts.

Coldrooms and deep freezers operated below  $-5^{\circ}\text{C}$  must be placed on flooring plates as protection against freezing. An electrical floor heating can be used instead of floor plating.

#### Installation outdoor

The Viessmann coldrooms are suitable for installation outdoor - but this must be done under a protective roof. (local construction measures)

If coldrooms are installed outdoor, discolouring of the paint may occur as a result of UV radiation.

**In addition to these assembly instructions, the applicable national and local rules on work safety must be observed when carrying out assembly work and the proper measures to prevent accidents must be taken!**

### 1.6 Disposing of the coldroom

Any waste materials must be disposed of in accordance with the local and international laws.

### 2.1 Compensation for uneven floor

(Please note accompanying coldroom drawing)  
Mark shape of coldroom on floor with chalk.

### 2.2 Coldrooms with flooring ventilation (Coldroom temperature under - 5°C)

The flooring gratings are laid loosely at a distance of 200 to 300 mm from each other. Ensure that the joins (B) and the exterior edges (A) are placed exactly on the flooring gratings. If there is unevenness in the flooring, the flooring gratings must be adjusted for height. The adjustment for height may be done using damp cement, fast setting adhesives or compensation plating. The adjustment should begin at the highest point.

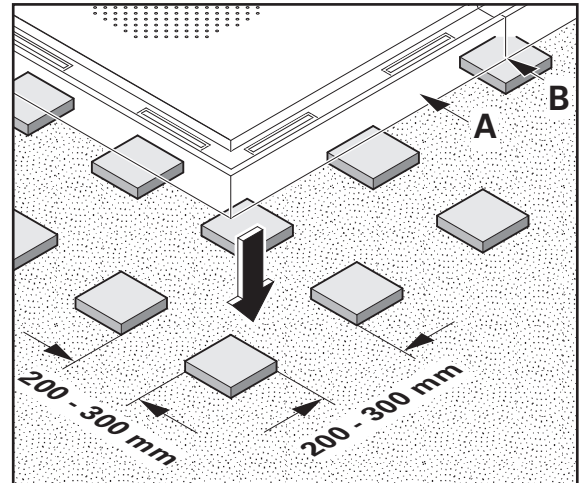

### 2.3 Coldrooms without flooring ventilation

In case of uneven or non horizontal flooring, compensate using floor underlays.

**Important!**

The panels are provided with seal at the plant - do not damage!

When transporting or moving the elements, do not grasp them by the overlap of the spring side or in their groove. Always hold the elements at the bottom, to prevent the sheets from coming loose.

All joining work is to be done carefully to prevent any and all penetration by water or contamination.

The individual coldroom elements are labelled. The respective position of each coldroom element can be ascertained by comparing the label on the coldroom, the provided drawing and BOM.

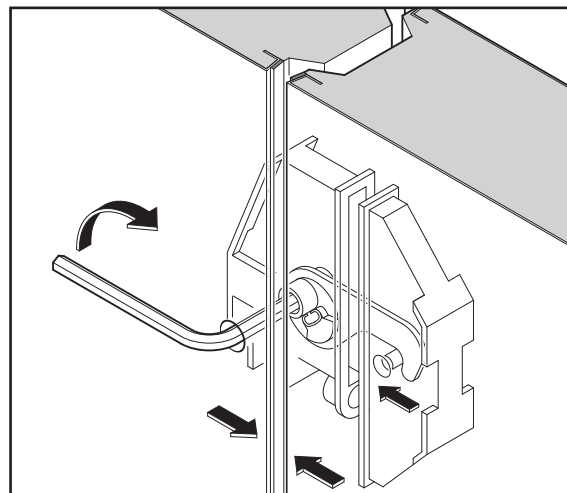

### 3.1 Connecting the coldroom panels

The coldroom panels are connected using foamed in eccentric cam locks. These are activated from the interior of the coldroom. Prior to assembly check that all the cam locks are open by turning them to the left. The cam locks have a pulling distance of 12 mm. If the distance between the coldroom panels is greater than 12 mm during assembly, the eccentric locks will not clamp in place. In this case, open the cam locks again and push the panels together, and then clamp the locks shut again.

### 3.2 Assembly of the flooring panels

#### Flooring panels with stainless steel covering plate:

The flooring panels are equipped with a sealing gasket (R) on the tongue side at the underlapping point. Ensure that this seal is not damaged.

For flooring panels with one or two sided connections, fill the points marked on the drawing with sealant.

Do not place weight on the panel to be assembled. Push the flooring panels together and tighten the external cam lock on one side. Push the opposite sides together, using a crow bar if necessary, taking care not to damage the part. Using the drill hole (S) provided in the surface of the top section, drill a hole in the end of the plate (T) and rivet the overlapping section.

#### Drilling lubricants:

e.g. Jokisch HDS 400, Chesterton 380

#### Closing the holes on cam locks (See picture next page).

Use PU sealant.

#### 1000 N flooring:

Plug  $\varnothing$  15 mm stainless steel

#### Attention: Using a steel hammer may cause rusting.

- pound in with rubber hammer

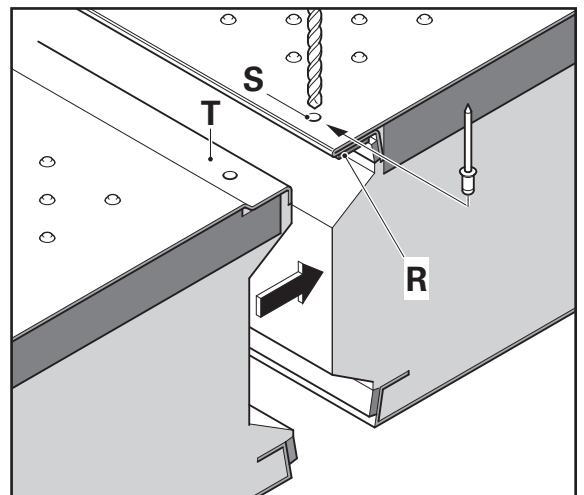
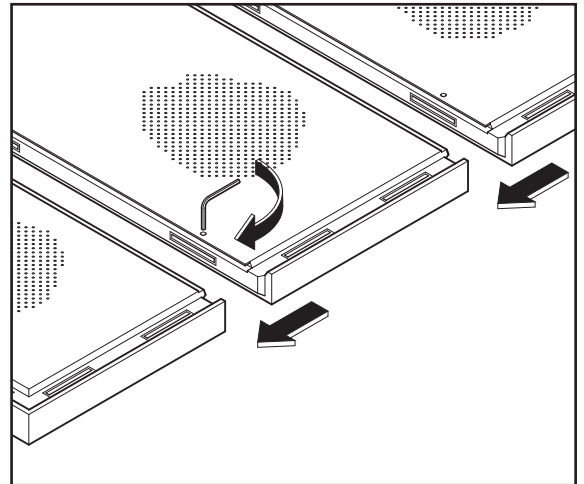

### 3.3 Assembly of the wall panels

Clean the interior flooring panel in the area of the interior wall plating C with isopropanol. Adhere the enclosed sealing gasket (D) to the cleaned edge of the interior flooring plate. Remove the protective foil from the sealing gasket.

Begin the wall assembly with the corner panels. Connect the panels using the cam locks.

### 3.4 Assembly of the door

The one piece door is supplied complete with the door frame.

**During assembly ensure that the doorframe is installed perfectly horizontally and vertically (plumb line).**

### 3.5 Assembly of the ceiling panels

When installing a wall-hanging unit, it must be hung on the side section of the door frame or on the wall before installing the ceiling elements. During installation ensure that the evaporator fan does not blow onto the door leaf and the pressure compensation valve.

Place the ceiling panels in position and tighten the cam locks.



#### Note!

If the panels are uneven, release the cam locks and adjust the panels. Tighten all cam locks (wall/ceiling, wall/wall, wall/floor) again.

### 3.6 Assembly of the door threshold

Place the stainless steel door threshold (G) in the middle of the door opening and adjust. Drill holes for fastening of the door threshold ( $\varnothing$  3.3 mm)



**Do not drill extra holes due to possible heating cable underneath. Danger to life!**

In order to seal the threshold securely against penetrating damp, apply a bead of polyurethane sealant (L) to the front of the door sill at the bottom, on the inside and on the sides.

Place door threshold plate on the flooring panel, adjust and rivet in place using enclosed rivets.

Seal the threshold with PU sealant on the sides of the door opening and to the floor.

Smooth off excessive sealant.

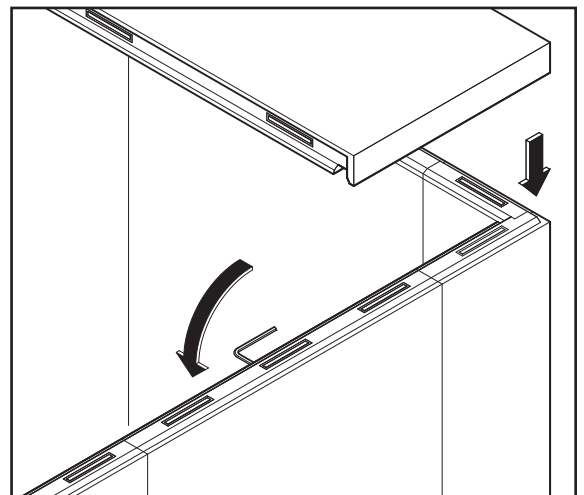
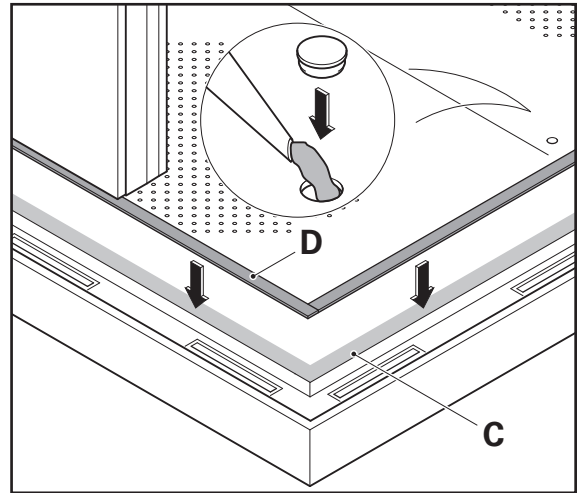

Montage Wand - Ceiling

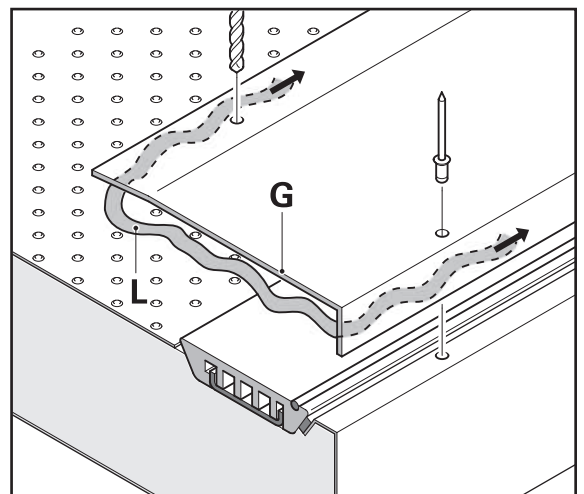

Montage Türschwelle



### 3.7 Removing transportation securing plates

The magnetic gasket seal on the door is protected from mechanical damage by means of the securing plates (M). Prior to adjusting the door and/or activation of the coldroom, these must be removed.

### 3.8 Adjusting the hinges



**Important!**

**If the magnetic gasket profile does not fit properly around the whole periphery of the door and the sealing profile does not lie flush on the threshold or the flooring on the inside, deviations can be adjusted for in three ways on the door hinges.**

Remove covering caps (N) from the door hinges. Open the door and insert a nail, a small screwdriver or something (M) similar diagonally into the opening (K) with the cap in order to release the cap locking.

After releasing the screw (P) or (R), the door can be adjusted horizontally or depthwise.

For vertical adjustment, turn the screws of the rising hinges (T) so that the door reaches the wanted height (see image).

The non-rising hinge can be mounted on the left or on the right side. It has the same screw (T) at the top and at the bottom. For vertical adjustment, turn the screw (T) so that the door is in the wanted height. For that, first release the upper screw (T) and then adjust the hinge turning the lower screw (T). Finally, fasten the upper screw (T) so that the hinge can still be moved easily.

### 3.9 Door lock fastener

The door lock fastener (V) of the hairpin lock has been factory-fitted at the plant. After assembly and adjustment of the door, the fit of the lock behind the door lock fastener should be tested.

If adjustment is necessary, loosen screws (U), and insert support (W) if necessary, adjust door lock fastener and tighten screws again.

Check that see if the door has a tight seal. After that, drill holes with a 3.7 mm drill and fix the fastener additionally with the screws provided (X).

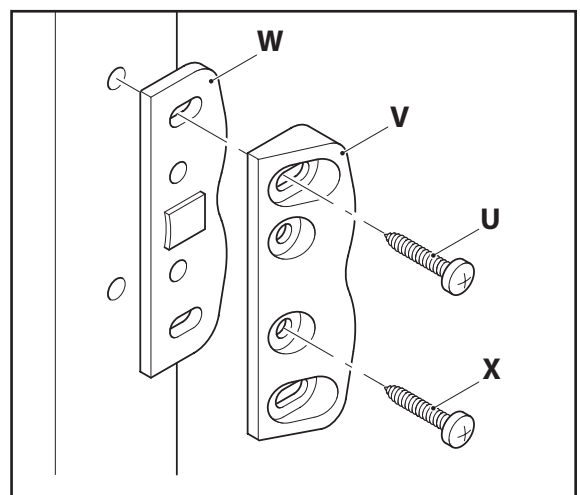
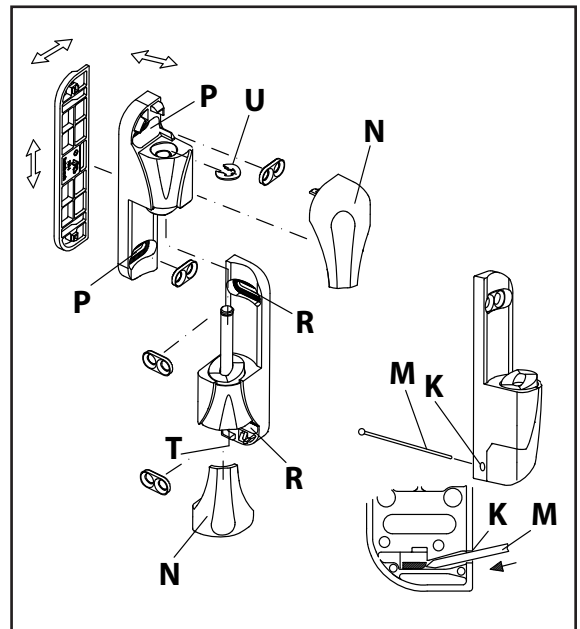
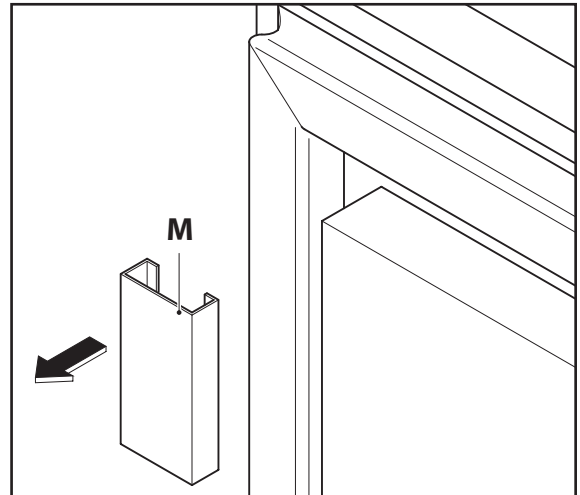

### 3.10 Mechanical works on the door or the hatch



**Important!**



**For door and view hatch panels, mechanical work in the marked area (e.g. drilling, sawing) is prohibited. This applies both for the exterior and for the interior. Electrical components have been foamed in here. Danger to life may result from damaging the integrated electrical wires!**

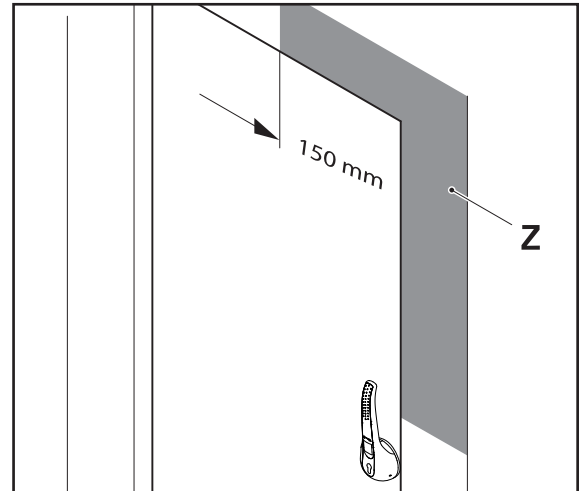

### 3.11 Coldroom without flooring panels

The wall panels are placed in plastic U-channels which are screwed onto the floor of the room in which the coldroom is assembled. These are constructed such that they form a seal with the floor of the building. During assembly the wall panels are either riveted to the U channels or screwed onto them.



**Caution!**

To avoid damage to the floor of the building, ensure prior to drilling in the floor that the cement coating does not contain a damp proof layer which might be damaged. In addition, the drill holes must be placed such that they are not under the cam locks of the panels.

**The door panel without flooring** is supplied with transport securing plates and without door frame heating. Remove transport securing plates for assembly of the door.

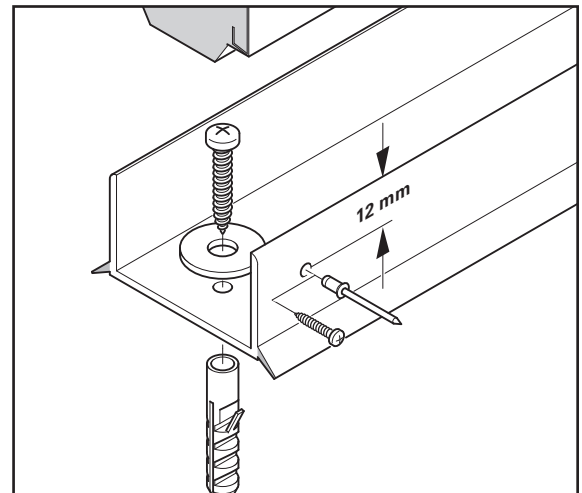

### 3.12 Closing the operational openings of the cam locks in the wall and ceiling panels

Fill the openings with the insulating foam fillers (D) and seal with plastic plugs (E).

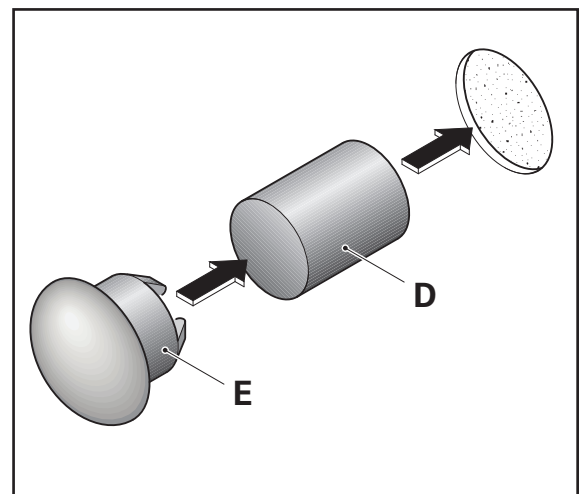



**5.1 Replacement of cylinder lock on rotary handle lock**

Unscrew the stud bolt (K) from the side of the outside handle using a 2.5 mm hexagon key (L).

Insert key (H) into the cylinder (F), turn to the horizontal position with  $\frac{1}{4}$  turn and remove cylinder lock with key.

Install in reverse sequence.

The key no. (G) is embossed at the front of the cylinder.

**5.2 Emergency release**

Check function of rotary handle lock, cylinder lock and emergency opening while the door is open.

The revolving doors can be opened with the emergency opener from the inside while the door is locked.

The door lock remains thereby in the locked condition.

**Check the emergency opener regularly.**

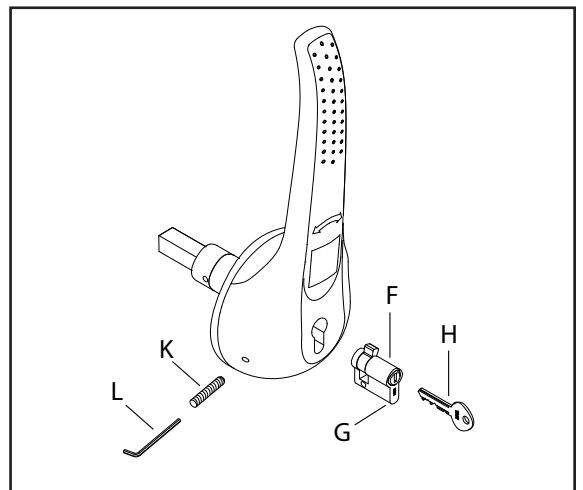
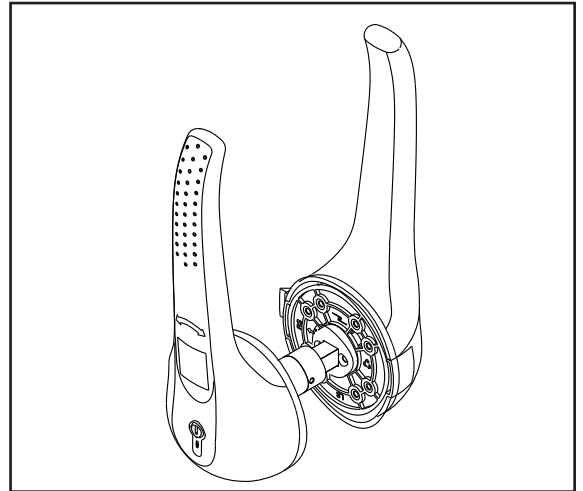

## 6.1 Commissioning the coldroom

- only for the intended or agreed purpose

After assembly, clean and ventilate the coldroom. (See section „Cleaning the Coldroom“).

The coldroom is ready to operate. The refrigeration unit can be activated according to the separate Operating Manual.

Allow the temperature in the coldroom to reach the desired value. Place refrigerated goods in the coldroom only when this value has been reached.

Have the pressure compensation valve checked by a refrigeration specialist. Do not exceed the allowed pressure differential in the coldroom of 100 Pa (1 mbar). Check the function of the pressure compensation valve regularly. The opening of the valve must not be blocked internally or externally (e.g. by refrigerated goods).

## 6.2 Permissible loads for flooring panels

	Wheel load N > 1 cm <sup>2</sup> hard bakery wheel	Wheel load N > 4 cm <sup>2</sup> rubber wheel	Wheel load in N/m <sup>2</sup>
1.	250	1000	30.000

## 6.3 Deactivation

When the coldroom is to be deactivated for a long period, the power supply plug must be disconnected or the power supply must be switched off. Provide sufficient ventilation!

## 6.4 Cleaning the coldroom

During cleaning the refrigeration unit and the coldroom should be cut off from the power supply.

**Remove the plug from the power supply during such work and secure against the plug being reinserted, or switch off the power supply at source and secure against switching on.**

Elements with powder-coated steel plate surfaces or stainless steel surfaces: do not spray water onto walls, ceilings, elements with electrical components (e.g. door frame) or the refrigeration units inside or outside. Wipe out the inside of the coldroom, dry well and allow ventilation. Do not use scouring agents or cleaning agents containing solvents. Wipe the outside of the coldroom with a damp cloth.

### Standard floor:

Only wipe with a moist cloth Not suited for stagnant water or jet water!

Wash the door seals regularly with soapy water and wipe dry. Do not clean the seals with Aceton or solventcontaining detergent.

The walls, shelves, containers and packing materials can be washed off with potassium sorbate solution (1 tablespoon of potassium sorbate dissolved in 0.1 litre of water. Potassium sorbate is produced by Merck and available at the local chemist's.) Wipe the walls, shelves, etc., with a linen towel dampened by the solution. The solution should dry onto the parts cleaned, leaving a light coat of residue.

The stainless steel coldroom flooring can be treated with normal stainless steel cleaners (e.g. ETOLIT, Fa. Viessmann). Seal the stainless steel surface with an appropriate material for stainless steel (e.g. Chromadur, Fa. Assindia-Chemie or Inox Top, Fa. Viessmann).

Pay attention to the product information!

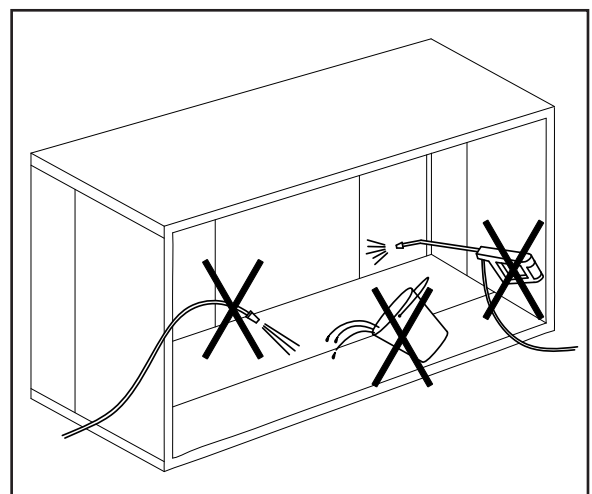

## 7. Energy saving and storage of refrigerated products

### 7.1 Notes on energy savings

Do not install coldrooms or refrigeration units near heating sources; if the ambient temperature is too high, this will force the refrigeration unit to run to activate too often.

- Direct radiation from the sun will increase power use.
- Allow warm food to cool down to room temperature before placing it in the coldroom.
- Avoid keeping the door open for longer than necessary.
- Monitor temperature of storage



**Caution!**

**Do not store substances with aggressive vapours (marinades, vinegar, etc.) in open containers, but rather in closed or covered containers.**

### 7.2 Storing refrigerated goods

When the desired temperature of storage is achieved in the coldroom, the refrigerated goods can be brought in. After this, the temperature in the coldroom should be checked again, and corrections in the regulation of the refrigeration unit made, if required.



Austria  
Viessmann Khlsysteme Austria GmbH  
Telephone +43 72 35 66367-0  
office\_vk\_at@viessmann.com  
**www.viessmann.at**

Belgium  
Viessmann Nederland B.V.  
Telephone +31 10 4584444  
info-ref-be@viessmann.com  
**www.viessmann.be**

Czech Republic  
Viessmann, spol. s r.o.  
Telephone + 420 257 090 900  
viessmann@viessmann.cz  
**www.viessmann.cz**

Denmark  
Viessmann Refrigeration Systems ApS  
Telephone +45 4120 5420  
info.dk@viessmann.com  
**www.viessmann.dk**

Estonia  
Viessmann Klmassteemid O  
Telephone +372 675 5150  
info.ee@viessmann.com  
**www.viessmann.ee**

Finland  
Viessmann Refrigeration Systems Oy  
Telephone +358 19 537 8000  
info.fi@viessmann.com  
**www.viessmann.com**  
Viessmann Kylmjrjestelmt Oy  
Telephone +358 19 537 8000  
info.fi@viessmann.com  
**www.viessmann.fi**

France  
Viessmann Technique du Froid S..r.l.  
Telephone +33 3 87 13 08 13  
france@viessmann-refrigeration.com  
**www.viessmann.fr**

Germany  
Viessmann Khlsysteme GmbH, Hof  
Telephone +49 9281 814-0  
Viessmann Khlsysteme GmbH, Mainz  
Telephone +49 61315 7046-17  
kuehlsysteme@viessmann.de  
**www.viessmann.de**

Ireland  
Viessmann Refrigeration Systems Limited  
Telephone +353 1 617 7930  
sales@viessmann-coldtech.ie  
**www.viessmann-coldtech.ie**

Latvia  
Viessmann Refrigeration Systems Latvia filile  
Telephone +371 6782 8449  
info.lv@viessmann.com  
**www.viessmann.com**

Netherlands  
Viessmann Nederland B.V.  
Telephone +31 10 4584444  
info-ref-nl@viessmann.com  
**www.viessmann.nl**

Norway  
Viessmann Refrigeration Systems AS  
Telephone +47 3336 3500  
post@viessmann.no  
**www.viessmann.no**

Poland  
Viessmann Systemy Chlodnicze Sp. z o.o.  
Telephone +48 22 882 0020  
info.pl@viessmann.com  
**www.viessmann.pl**

Russia  
Viessmann Group – Refrigeration Systems  
Moscow, St. Petersburg  
Telephone +7 499 277 1260  
**www.viessmann.ru**

Slovakia  
Viessmann, s.r.o.  
Telephone +421 32 23 01 00  
viessmann@viessmann.sk  
**www.viessmann.sk**

Sweden  
Viessmann Refrigeration Systems AB  
Telephone +46 8 5941 1200  
info.refrigeration@viessmann.se  
**www.viessmann.se**

Switzerland  
Viessmann (Schweiz) AG  
Telephone +41 56 418 67 11  
info@viessmann.ch  
**www.viessmann.ch**

United Arab Emirates  
Viessmann Middle East FZE  
Telephone +971 43724247  
refrigeration@viessmann.ae  
**www.viessmann.ae**

United Kingdom  
Viessmann Refrigeration Systems Limited  
Telephone +44 1952 457157  
sales@viessmann-coldtech.co.uk  
**www.viessmann.co.uk**